



TEREX

TG190

Motor Grader

MAX. GROSS VEHICLE WEIGHT	41,266 lbs (14,500 kg)
GROSS ENGINE POWER	176 hp (125 kW)
MOLDBOARD WIDTH	12' 0" (3,660 mm)



MOTOR GRADER TG190

Specifications

Engine

Make/model	Cummins/diesel engine
Type	4 cycle, direct injection, turbo charged, water-cooled
Rated net horsepower (ISO/TR 14396)	
at 2,200 rpm	176 hp (125 kW)
at 2,000 rpm	185 hp (135 kW)
No. of cylinders	In-line 6
Bore and stroke	4 x 5 in (100 x 127 mm)
Displacement	366 cu in (6 L)
Engine equipped with a dual element, dry-type air cleaner with dust ejector. 24 volt starting and electrical system. 55 amp alternator and 24 volt starter with 8.7 hp (4.5 kW).	

Operating Weight

Total weight	approx. 41,266 lbs (18,700 kg)
On rear wheels	approx. 30,203 lbs (13,700 kg)
On front wheels	approx. 11,023 lbs (5,000 kg)

Weights shown include cab, all operating fluids, 6-teeth rear ripper, front dozer blade.

All Wheel Drive System

6 speed auto power shift transmission with torque converter, hydrostatic drive on front axle when equipped with AWD. Power train is controlled appropriate to tire traction.

Operator's Cab

Integrated ROPS/FOPS cab mounted on isolators to limit vibration and noise entering the cab. Excellent all-round visibility. Roomy and comfortable. Adjustable steering pedestal with EURO/TEREX control lever arrangement. Interior of cab is fully lined and has a durable floor covering. Tinted safety glass, sliding doors on each side with lockable intermediate positions. Fresh air heating with pre-filter and air circulation. Adjustable hydraulically sprung drivers seat with seat belt. One inside mirror and two folding outside mirrors. Blinds front and rear. Front window washer and window wipers front and rear.

Specifications

Rear Axle Drive System

6 speed auto power shift transmission with torque converter, hydrostatic drive on front axle when equipped with AWD.

Speed	Forward						Reverse		
	1	2	3	4	5	6	1	2	3
Gear	1	2	3	4	5	6	1	2	3
mph	2.4	4.1	5.5	9.6	12	24.9	2.4	5.5	12
km/h	3.8	6.8	8.8	15.4	19.4	40	3.8	8.8	19.4

Rear Axle

Oscillating tandem axle with axle insert

No-Spin differential

Multi-disc brakes in all four wheel hubs

Parking brake mechanical operated, acting on power shift

Tandems

Drive via roller chains

Torsion-proof box section

Height 20 in (517 mm)

Width 7 in (184 mm)

Thickness of walls 0.9 in (22 mm)

Wheel base 5 ft 1 in (1,542 mm)

Oscillation $\pm 15^\circ$

Ground Clearance 18.6 in (474 mm)

Front Axle

3 types are available:

Oscillation 15° up and down

Steering angle 45°

Non driven with wheel lean (T-version)

Stable welded steel beam with wheel lean

Wheel lean $\pm 17^\circ$

Ground clearance 23.26 in (591 mm)

Driven without wheel lean (TA-version 1)

Stable tractor-based axle with axial piston engine (concentric on axle protected), pulling power on surface conditions electronically adjustable (infinitely variable).

Differential, self locking 45%

Ground clearance 18.54 in (471 mm)

Driven with wheel lean (TA-version 2)

Stable welded steel beam with wheel lean and radial piston engines in wheel hubs, pulling power on surface conditions.

Electronically adjustable (infinitely variable), possibility to fit in the hydraulic differential lock.

Wheel lean $\pm 17^\circ$

Ground clearance 23.26 in (546 mm)

Brakes

Service brake: Dual circuit, power-assisted, multiple-disc, oil-bath type, effective on four wheels, includes reserve power and operator warning system.

Parking brake: Independent hand operated, acting on power shift.

Tires and Wheels

Tires 14.00 -24 TG

Rims 10.00 x 244

Steering

Hydrostatic power steering

Minimum turning radius with dozer blade 26 ft 4 in (8,050 mm)

Minimum turning radius without dozer blade 24 ft 6 in (7,500 mm)

Steering angle 45°

Frame

Front and rear frame sections connected with an adjustment-free articulated pin.

Front: Fully welded box section

Minimum dimensions of box section 10.8 x 10.2 in (300 x 310 mm)

Plate thickness 0.78 in (20 mm)

Rear: Fully welded section

Dimensions (solid main bars) 10.6 x 3.5 in (270 x 90 mm)

Hydraulic articulated frame steering (left & right) 30°

Circle

Hardened teeth, cut on inside of circle for maximum strength and minimum wear. The circle is held positively in place at four points by four clamps and guide shoes. The clamp and guide shoes are located where greatest loading occurs.

Diameter 4 ft 11 in (1,510 mm)

Thickness 1.6 in (40 mm)

Height 4.3 in (110 mm)

Adjustable guide shoes and clamps

Circle Drive

Hydraulically driven worm gear transmission. Circle drive system fully protected against impact damage by an overload clutch.

Drawbar

Y-shaped fully welded construction

Dimensions (solid sections) 1.6 x 8.3 in (40 x 210 mm)

Moldboard (standard)

Moldboard 12 ft x 24.8 x 0.79 in (3,660 x 630 x 20 mm)

Blade material High carbon steel

Blade pull (at a friction factor of 0.8)

TG190 T-3 21,683 lbf (96.45 kN)

TG190 TA-3 31,264 lbf (135.07 kN)

Specifications

Blade Range	
Reach outside tires without articulation (RH&LH) blade resting on leveled surface	7 ft 1 in / 4 ft 6 in (2,155 / 1,370 mm)
Reach outside tires with articulation (RH&LH) blade resting on leveled surface	9 ft 6 in / 7 ft 3 in (3,180 / 2,220 mm)
Blade side shift	4 ft 1 in (1,250 mm)
Blade tilt range	38° to 78°
Bank sloping angle (RH&LH)	90°
Lift above ground	18.5 in (470 mm)
Cut above ground	14.9 in (380 mm)
Distance blade/front axle	8 ft 7 in (2,638 mm)
All blade movements and positions can be controlled from the operator's seat.	

Operator's Platform	
Width	3 ft 8 in (1,150 mm)
Depth	4 ft 7 in (1,400 mm)
Available with various options as listed under "Optional equipment", moldboard control acc. to EURO-standard.	

Light Equipment	
2 headlights front, 2 direction indicator lights each (including warning signal flasher) front and rear and additional 2 at cab, 2 tail lights. 2 stop lights, 1 back-up light, clearance lights, 2 working lights rear, two working lights front each at lower and upper edge of cab.	

Load-Sensing Hydraulics	
The control valves of the working hydraulics may be actuated at a time and independent of each other. The load-sensing pump (axial piston pump) discharges only the required amount of oil, if a control valve is actuated. When hydraulic power is not required, system pressure is only 348 psi (24 bar) and this low standby pressure improves fuel-efficiency and reduces heat generation.	
Operating pressure	2,669 psi (184 bar)
Oil flow, maximum	26.1 gpm (99 Lpm)

Service Capacities	
Fuel tank	126.8 gal (480 L)
Hydraulic oil tank	44.9 gal (170 L)
Engine crankcase (with filters)	3.96 gal (15 L)
Ergopower transmission	8.98 gal (34 L)
Axle drive front (TG190 TA-3)	2.64 gal (10 L)
Axle drive	7.66 gal (29 L)
Final drive, front (TG190 TA-3)	0.79 gal (3 L)
Planetary gears and brakes	3.69 gal (14 L)
Tandem case 2 x 5.5 gal (2 x 21 L)	11.09 gal (42 L)
Circle drive	1.58 gal (6 L)
Coolant	11.09 gal (42 L)

Dimensions

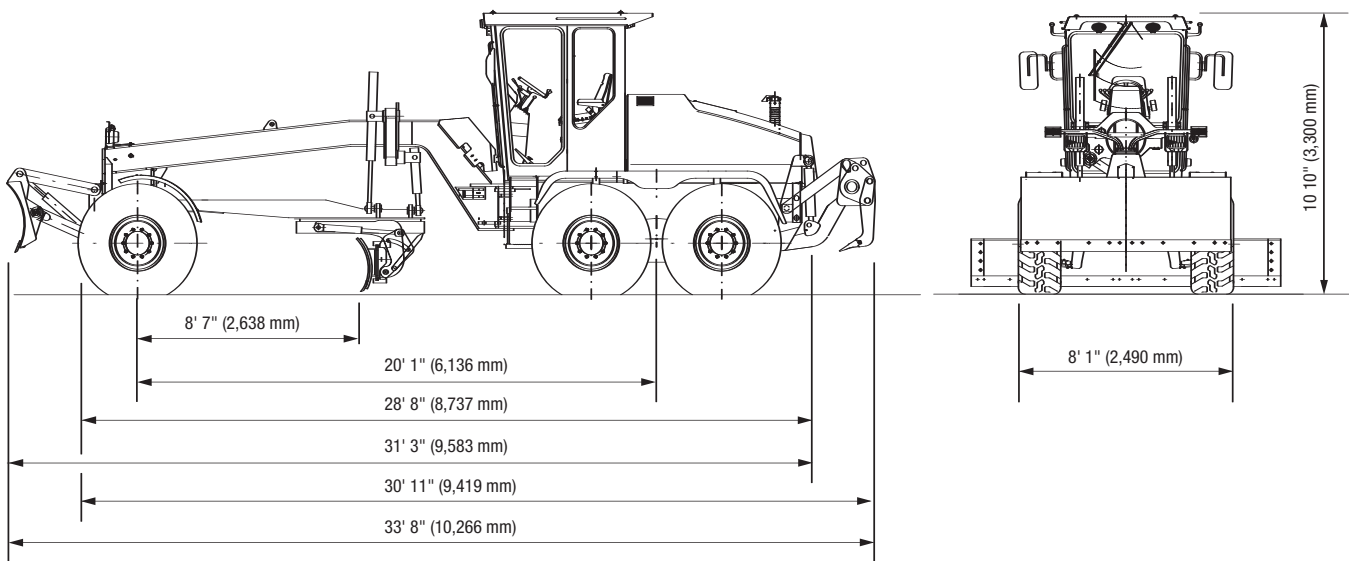

Motor Grader TG190

Optional Equipment

Cab	
Air-conditioned cab	
Auxiliary heating	
Beacon (orange)	
Air-cushioned driver's seat	
Recording speedometer	
Cooling box	
Stereo radio with cassette	
Sliding side windows	
Protective grids for lights and cabin	
Circle Drawbar	
Hardened teeth, machine-cut on inside of circle for maximum strength and minimum wear. The circle is held positively in place by an adjustment-free roller bearing. Drawbar fully welded solid section in "Y" design.	
Circle diameter	4 ft 11 in (1,510 mm)
Tool width	3.64 in (83 mm)
Height	5 ft 1 in (130 mm)
Moldboard	12 ft 11 in x 24.8 in x 0.78 in (3,962 x 630 x 20 mm) 11 ft x 24.8 in x 0.78 in (3,355 x 630 x 20 mm)
Cover plate for upper guide rail of moldboard	
Adjustable moldboard corner shoe, left hand and right hand	
Moldboard extension, left or right	12 in (305 mm)
Float position for both moldboard lift cylinders	
Electric fuel pump with automatic switch-off	
Towing device, tiltable	

Wheels and tires	Rim size
17.5-25 SGL D/L-2A Goodyear	14.00 x 25/1.3
17.5 R25 XS NO PLUS Michelin (M+S)	14.00 x 25/1.3
17.5 R25 TL XHA Michelin	14.00 x 25/1.3
17.5 R25 RL-2+ Goodyear	14.00 x 25/1.3
Rear ripper with depth penetration indicator	4 teeth
Width	7 ft 11 in (2,120 mm)
Ripping depth	10.23 in (260 mm)
Lift above ground	24.8 in (630 mm)
Weight	1,151 lbs (522 kg)
Heavy duty ripper, with depth penetration indicator	6 teeth
Width	7ft 11 in (2,120 mm)
Ripping depth	14.76 in (375 mm)
Lift above ground	23.22 in (590 mm)
Weight	1,151 lbs (1,529 kg)
Ripper between front axle and moldboard, with position indicator	11 teeth
Width	55.1 in (1,400 mm)
Ripping depth	9.8 in (250 mm)
Lift above ground	16.1 in (410 mm)
Weight	2,028 lbs (920 kg)
Front dozer, articulated	
Front dozer, removable	
Front ballast instead of dozer blade	877 lbs (380 kg)
Mudguards on rear wheels	
Mudguards on front wheels	
Articulation angle indicator	
Special paint	
Tool kit, wheel chocks, warning triangle, fire extinguisher etc.	
Automatic blade control	
Various automatic laser or ultrasonic controlled blade systems	



TEREX Construction Americas

8800 Rostin Road
Southaven, MS 38671
USA

TEL 662-393-1800
SALES 866-837-3923
PARTS & TECH SUPPORT 888-201-6008
FAX 662-393-1700
EMAIL sales@terexca.com
WEB terexca.com

For more information, product demonstration, or details on purchase, lease and rental plans, please contact your local TEREX Distributor.