



# TEREX

# HR32

## Compact Crawler Excavator

<b>OPERATING WEIGHT</b>	16,538 – 17,420 lbs (7,500 – 7,900 kg)
<b>NET ENGINE POWER</b>	72 hp (53 kW)
<b>MAX DIG DEPTH</b>	14' 7" (4.44 m)
<b>MAX REACH</b>	24' 5" (7.44 m)



COMPACT CRAWLER EXCAVATOR  
**HR32**

### Operating Data, Standard Equipment

Operating weight - monobloc boom (SAE J 732)	16,538 lbs (7,500 kg)
Operating weight - circular boom (SAE J 732)	17,420 lbs (7,900 kg)
Undercarriage (steel crawlers)	+550 lbs (250 kg)
Overall length (travel position - monobloc boom)	13' 7" (4.2 m)
Overall length (travel position - circular boom)	13' 7" (4.2 m)
<b>Transport dimensions:</b>	
Monobloc boom (L x H)	19' 9" x 8' 9" (6.0 x 2.7 m)
Circular boom (L x H)	19' 4" x 8' 9" (6.0 x 2.7 m)
Overall height (travel position - monobloc boom)	14' 3" (4.3 m)
Overall height (travel position - circular boom)	12' 9" (3.9 m)
Total width with dozer blade	7' 6" (2.3 m)
Total height (top of cab)	8' 9" (2.7 m)
Tread width	6' 2" (1.9 m)
Ground clearance	16" (408 mm)
Uppercarriage tailswing	3' 10" (1.2 m)
Uppercarriage front swing (monobloc boom)	7' 7" (2.3 m)
Uppercarriage front swing (circular boom)	5' 5" (1.7 m)
Working envelope, 180°	11' 5" (3.5 m)
Working envelope, 360° (monobloc boom)	15' 1" (4.6 m)
Working envelope, 360° (circular boom)	10' 10" (3.3 m)
Bucket force (SAE J 1179)	11,970 lbs (53,200 N)
Stick force (SAE J 1179)	9,585 lbs (42,600 N)
Ground pressure	4.4 psi (0.31 daN/cm <sup>2</sup> )

## Specifications

Engine	
Manufacturer, model	Deutz, KHD BF 4 M
Type	4-cylinder, turbocharged diesel engine
Combustion	4-stroke, direct injection
Displacement	195 in <sup>3</sup> (3.2 L)
Net power rating at 2,000 rpm (SAE J 1349)	73 hp (54 kW)
Cooling system	Oil

Electrical System	
Nominal voltage	12 V
Battery	12 V / 105 Ah / 450 A

Power Transmission	
Hydrostatic drive with reduction gear. Gear-integrated multi-disc brake acting as service and parking brake, automatically hydraulically bled; 2-stage variable displacement motor, full power shift.	
2 speed ranges:	
Travel speed forward/reverse	0 – 1.7 mph (0 – 2.7 km/h) 0 – 3.2 mph (0 – 5.2 km/h)
Gradeability	> 60%
Drawbar pull	13,613 lbs (60.5 kN)

Undercarriage	
Maintenance-friendly crawler-type undercarriage with triple grouser plates or rubber crawlers. Idler suspension with hydraulic crawler tensioning.	
Steel crawlers / rubber crawlers	18" / 18" (450 / 450 mm)
Total length (sprocket/idler)	7' 2" / 7' 4" (2,202 / 2,247 mm)
Total length (undercarriage)	9' 4" (2.9 m)

Dozer Blade	
Independent from drive train, sensitive control via hand lever.	
Width	7' 6" (2.3 m)
Cut below ground	15" (390 mm)
Lift above ground	20" (500 mm)
Slope angle	35°

Steering	
Independent control of tracks via hand controls or foot pedals.	

Swing System	
Hydrostatic drive with 2-stage planetary gear and fixed axial piston displacement motor. In addition, automatically controlled spring-loaded multi-disc brake acts as swing brake when the pilot control lever is in neutral position.	
Swing speed	0 – 10 rpm

Quick Attach	
Mechanical quick attach for easy and fast exchange of attachments as standard.	

## Hydraulic System

**Working hydraulics:** Axial piston pump with load-sensing, coupled with a load-independent flow division (LUDV). Simultaneous, independent control of all movements. Sensitive maneuvers irrespective of loads.

Maximum working pressure	4,060 psi (280 bar)
--------------------------	---------------------

Pump capacity	41 gpm (156 Lpm)
---------------	------------------

Gear pump for all positioning and swing movements.

Pump capacities	18 gpm (68 Lpm)
-----------------	-----------------

Maximum working pressure	3,335 psi (230 bar)
--------------------------	---------------------

Tank-immersed return filter with electric contamination indicator and full flow filtration. Hydraulic oil radiator provided as standard. Boom, dipperstick and articulated cylinders with end-position damping on both sides and bucket retract function with one-side end-position damping. Two-way auxiliary control circuit for work attachments provided as standard.

**Auxiliary hydraulics:**

Maximum working pressure	4,060 psi (280 bar)
--------------------------	---------------------

Flow (adjustable)	maximum 26.4 gpm (100 Lpm)
-------------------	----------------------------

Additional two-way auxiliary circuit is available through a switch-over on the bucket circuit. Open (pressureless) return as standard. All functions can be activated proportionally. Two servo-assisted joystick controls for excavator operations. Shut-off of all working functions when dismounting the machine.

A/B control pattern switch standard.

Hose rupture safety valves associated with overload warning device on boom cylinder standard.

## Knickmatik®

Boom offset to provide lateral parallel adjustment at full digging depth

Angle of artic./ lateral adjustment left	63°/2' 8" (63°/ 815 mm)
--	-------------------------

Angle of artic./ lateral adjustment right	65°/3' 1" (65°/ 950 mm)
---	-------------------------

## Cab

Spacious, sound-insulated full-vision steel cab with large access door. Safety glass windows, thermo windows tinted in green. Skylight thermo window. Front window supported by pneumatic springs, lockable in place for ventilation and slideable under cab roof. Windshield washer. Glove box. Instrument panel to the right of the operator's seat with visual and acoustic warning device. Left-hand, outside rear-view mirror. Cab heating with windshield defroster through coolant heat exchanger and 3-setting fan and ventilating mode in summer. Fabric-covered, hydraulically cushioned operator's seat with height-adjustable armrests, height, tilt and weight adjustments and seat belt.

Working floodlight Halogen H-3.

Noise emission ambience LWA / Noise emission cab LpA	101/ 77 dB (A)
--	----------------

Optional FOPS approved skylight guard available.

## Fluid Capacities

Fuel tank	34 gal (130 L)
-----------	----------------

Hydraulic system	37 gal (140 L)
------------------	----------------

**Circular Boom Position Load-Over Height Top View**

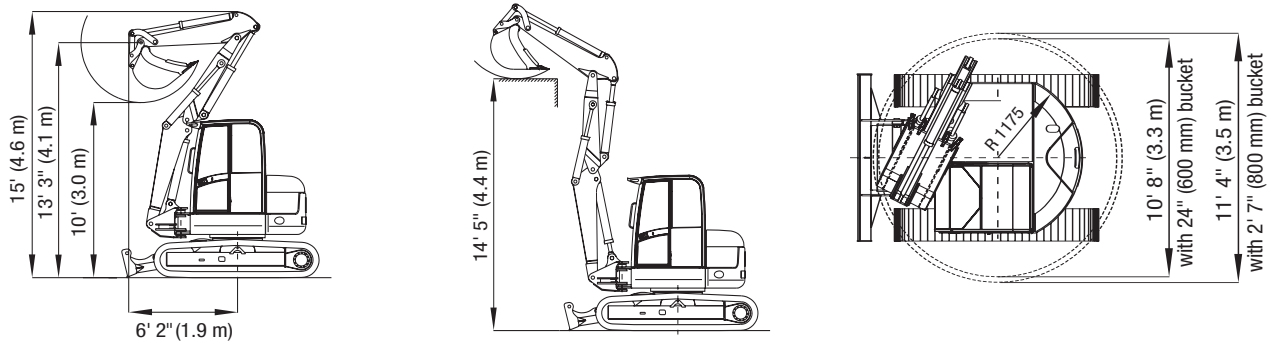

**Working Ranges & Dimensions: Monobloc Boom**

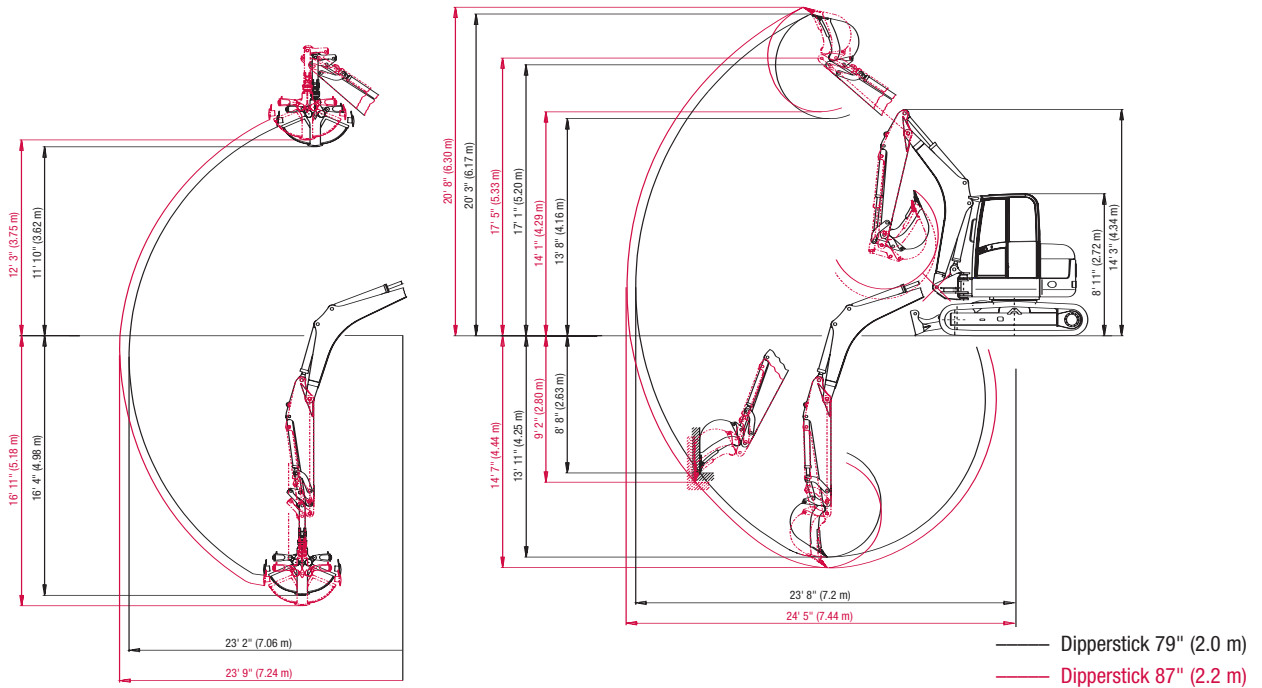

**Lifting Capacities: 79" (2.0 m) Dipperstick**

Unit: x 1,000 lbs (Metric tons)		Load radius from the center of the ring gear							
Bucket hinge pin height		9' 10" (3.0 m)		13' 1" (4.0 m)		16' 5" (5.0 m)		19' 8" (6.0 m)	
		End	Side	End	Side	End	Side	End	Side
9' 10" (3.0 m)	Supported by blade	—	—	5.55 (2.52)	3.37 (1.53)	4.32 (1.96)	2.20 (1.00)	—	—
	Traveling	—	—	3.31 (1.65)	3.31 (1.50)	2.49 (1.13)	2.18 (0.99)	—	—
4' 11" (1.5 m)	Supported by blade	7.14 (3.24)	5.14 (2.33)	5.75 (2.61)	3.13 (1.42)	4.72 (2.14)	2.14 (0.97)	3.83 (1.74)	1.52 (0.69)
	Traveling	4.96 (2.25)	5.07 (2.30)	3.50 (1.59)	3.06 (1.39)	2.34 (1.06)	2.07 (0.94)	1.65 (0.75)	1.48 (0.67)
0	Supported by blade	11.68 (5.30)	3.97 (1.80)	7.01 (3.18)	2.82 (1.28)	4.98 (2.26)	1.98 (0.90)	3.64 (1.65)	1.50 (0.68)
	Traveling	4.85 (2.20)	3.97 (1.80)	3.11 (1.41)	2.71 (1.23)	2.18 (0.99)	1.92 (0.87)	1.61 (0.73)	1.43 (0.65)
-3' 3" (-1.0 m)	Supported by blade	10.14 (4.60)	3.97 (1.80)	6.46 (2.93)	2.42 (1.10)	4.63 (2.10)	1.89 (0.86)	3.24 (1.47)	1.46 (0.66)
	Traveling	4.56 (2.07)	3.75 (1.70)	2.91 (1.32)	2.42 (1.10)	2.07 (0.94)	1.85 (0.84)	1.59 (0.72)	1.39 (0.63)

The above loads (all values in lbs x 1,000 resp. metric tons) are in compliance with SAE J 1097. They do not exceed 87% of hydraulic lifting capacity or 75% of tipping capacity. In each case, the smaller value is indicated. All values were determined with load hook. In the event of an attached bucket the difference weights bucket minus load hook must be deducted from the permissible payloads. When used for crane operations, excavators must be equipped with hose-rupture safety valves and overload warning device. Working equipment: Rubber crawlers, monobloc boom, dipperstick 79" (2.0 m).

# Compact Crawler Excavator HR32

## Optional Attachments / Accessories

Optional Accessories	
Dipperstick	87" (2.2 m)
Quick-change plate for hydraulic hammer operation	
FOPS skylight guard	
Independent diesel heating with timer	
Electrical tank refueling pump	
Filling with biodegradable hydraulic oil, ester-based VI 68	
Air-cushioned driver's seat	
Set of working floodlights (cab-mounted, front and rear)	
Hydraulic boom height limitation	
Radio control	
Electric drive	

Optional Attachments (QAS)		
	Width	Capacity
Bucket, tapered	11" (290 mm)	3.33 ft <sup>3</sup> (95 L)
Bucket, tapered	14" (350 mm)	4.03 ft <sup>3</sup> (115 L)
Bucket, tapered	18" (450 mm)	5.60 ft <sup>3</sup> (160 L)
Bucket with ejector	11" (290 mm)	2.28 ft <sup>3</sup> (65 L)
Bucket with ejector	14" (350 mm)	2.98 ft <sup>3</sup> (85 L)
Bucket with ejector	18" (450 mm)	4.03 ft <sup>3</sup> (115 L)
Bucket	24" (600 mm)	8.40 ft <sup>3</sup> (240 L)
Bucket	31" (800 mm)	11.80 ft <sup>3</sup> (335 L)
Cable-laying bucket	9" (220 mm)	–
Ditch-cleaning bucket	59" (1,500 mm)	9.45 ft <sup>3</sup> (270 L)
Swing bucket, 2 x 40°	49" (1,250 mm)	7.00 ft <sup>3</sup> (200 L)
Swing bucket, 2 x 40°	59" (1,500 mm)	9.2 ft <sup>3</sup> (260 L)

Clamshell Grabs		
	Width	Capacity
GM 2325	13" (325 mm)	4.73 ft <sup>3</sup> (135 L)
GM 2400	16" (400 mm)	5.95 ft <sup>3</sup> (170 L)
GM 2500	20" (500 mm)	7.70 ft <sup>3</sup> (220 L)
GM 2600*	24" (600 mm)	9.10 ft <sup>3</sup> (260 L)

Hydraulic Hammer	
Sound-insulated. Tools: Moil point and chisel	

Optional Boom	
Circular boom, dipperstick	65" (1,650 mm)

Crawler-type Options	
Steel crawlers (width)	18" (450 mm)

\*Attachments not permitted for every type of boom. Please inquire.

Further attachments and accessories available on request.



### TEREX Construction Americas

8800 Rostin Road  
Southaven, MS 38671  
USA

TEL 662-393-1800  
SALES 866-837-3923  
PARTS & TECH SUPPORT 888-201-6008  
FAX 662-393-1700  
EMAIL sales@terexca.com  
WEB terexca.com

For more information, product demonstration, or details on purchase, lease and rental plans, please contact your local TEREX Distributor.

Effective date: October 1, 2005. For further information, please contact your local distributor or the TEREX sales office listed. Product specifications are subject to change without notice or obligation. The photographs and drawings in this brochure are for illustrative purposes only. Refer to the appropriate Operator's Manual for instructions on the proper use of this equipment. Failure to follow the appropriate Operator's Manual when using our equipment or to otherwise act irresponsibly may result in serious injury or death. Prices and specifications subject to change without notice. The only warranty applicable is the standard written warranty applicable to the particular product and sale. TEREX makes no other warranty, expressed or implied. Products and services listed may be trademarks, service marks or trade-names of TEREX Corporation and/or its subsidiaries in the USA and other countries and all rights are reserved. "TEREX" is a Registered Trademark of TEREX Corporation in the USA and many other countries. Copyright ©2006 TEREX Corporation