



A TEREX BRAND

Features

- Heat treated hardened cast steel splitting cone.
- Replaceable hardened alloy steel tip.
- Compact and ruggedly built for extreme-duty service and years of trouble-free operation.
- Various sizes are available to fit almost any machine with auxiliary hydraulics.
- Powered by a 94HP Poclairn MSE-18 high-torque motor.

Description

The CBI Log & Stump Screw attachment is an engineered solution for splitting over-sized butt logs, pole wood, tree service block wood, and stumps into a more manageable size. The wood can then be further processed into firewood, wood fuel or other valuable end products. In addition, the screw can be used to break apart old pilings, telephone poles, and right-of-way mats to release them of embedded steel hardware so they can be processed more effectively in a grinder.

The model size of the splitter depends on the hydraulic flow capacity, pressure available, and tonnage of the machine the splitter is to be mounted to. The splitter can be configured for direct pin, quick-coupling, and universal skid steer mounting.

It is powered by a 94HP Poclairn MSE-18 high-torque hydraulic motor. With the ability to operate at pressures up to 5,800 PSI, the Log & Stump Screw splits open the toughest stumps and logs with ease. The higher the auxiliary circuit pressure, the greater the torque to split wood with flow adjusted to speed range of 30-60 RPM.

The XLP, with the mounting adapter and pins, weighs approximately 1,500 lbs. The provided 4140 alloy steel pins and 3/4" thick adapter plated with 5-1/2" OD line-bored bosses are mounted to the splitter's main housing with (12) 1" bolts and are manufactured to fit the specific machine dimensions.

The XLP has a 16" diameter x 26" high heat treated (45 Rockwell) cast 4340 steel cone is built to split the harshest of wood. The replaceable 4140 steel tip is heat treated (45 Rockwell) and is easily replaced with the removal of three pins. The XP, with the mounting adaptor and pins, weighs approximately 680 lbs. and has a 14" diameter x 22" high heat treated cone.

CBI Log & Stump Screw

Attachment

Models XP & XLP

Splits wood up to 7 feet in diameter.



“We had a bunch of big old maple logs that needed to be reduced for our grinder and this CBI XLP Stump Screw split it without hesitation. We use it daily for all oversized material.”

- Steve Johnson, Owner of
Barnard Excavating & Logging



Splitter Model	Splitter Weight		Cone Size Hgt x Dia		Shaft Diameter		Unit Fits on Pallet Size		Max. Split. Size - Dia x Lg		Oil Quantity*		Oil Pressure		Carrier Wt.	
	(lbs)	(kgs)	(in)	(mm)	(in)	(mm)	(in)	(mm)	(ft)	(m)	(gpm)	(lpm)	(psi)	(bar)	(ton)	(metric ton)
CBI XP	680	205	17x14	432x356	Wheel drive Poclairn internal shaft		43x20x18	1093x508x458	3.3x13	1x4	10-25	37.94.5	3,000-5,000	345-207	3.0-12.0	2.7-11
CBI XLP	1500	540	20x16	508x407	5.15/16	150	65x28x22	1651x712x560	7.0x20	2x6	20-50	37-189	3,000-5,000	345-80	10.0-30.0	9.0-28

Specifications

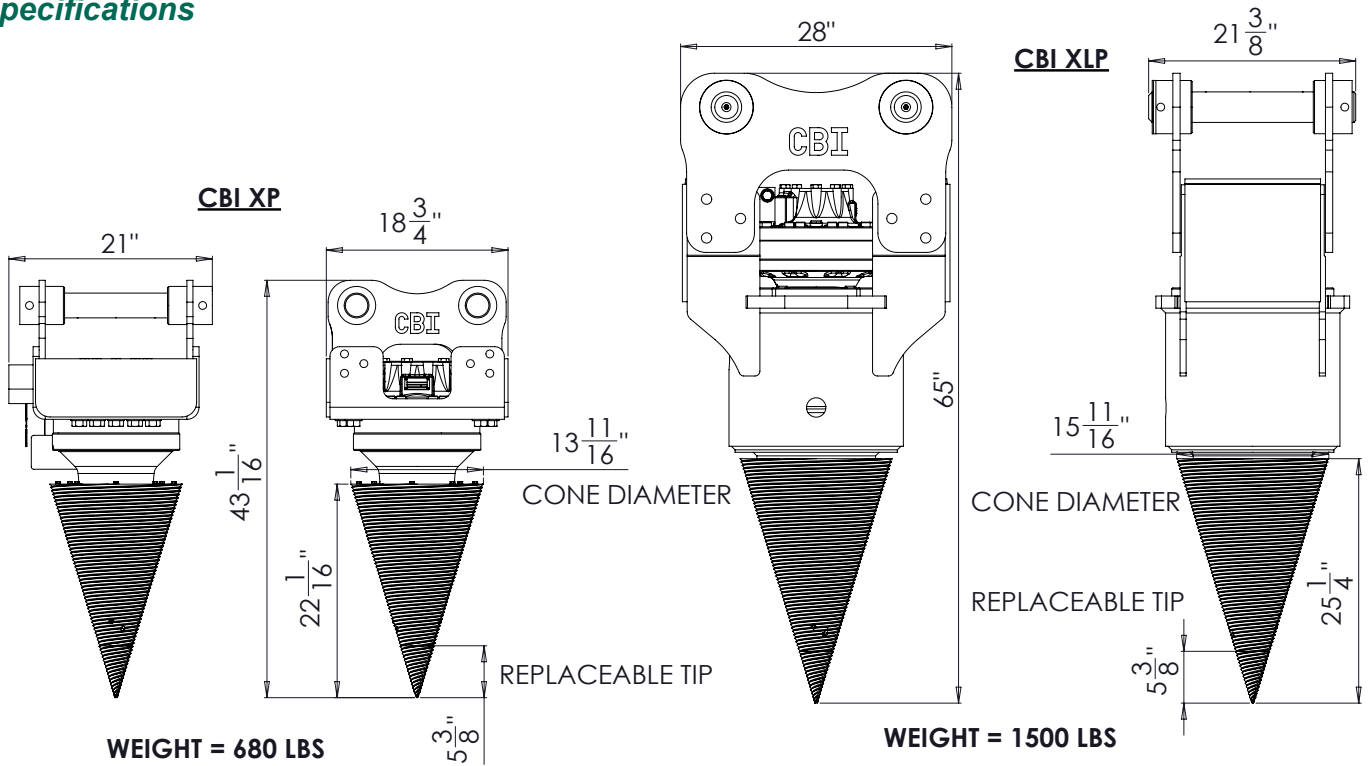

WEIGHT = 680 LBS

MAXIMUM MACHINE WEIGHT = 24,000 LBS

**CAPABILITIES:
FLOW: 10 - 25 GPM
PRESSURE: 3000 - 5000 PSI**

WEIGHT = 1500 LBS

MAXIMUM MACHINE WEIGHT = 50,000 LBS

**CAPABILITIES:
FLOW: 20 - 50 GPM
PRESSURE: 3000 - 5000 PSI**



Continental Biomass Industries

World's best stationary and portable material recovery systems.
22 Whittier Street, Newton, NH, 03858
Phone: (603) 382-0556 Fax: (603) 382-0557
Web: cbi-inc.com Email: info@cbi-inc.com

Distributed by: