

**TECHNICAL
SPECIFICATION**



MF24H

ORGANIC FEEDER

MF24H ORGANIC FEEDER

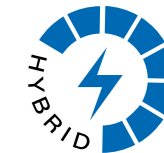

OVERVIEW

| | | |
|---------------|--|----------------|
| Total Weight | 24,350kg (53,683bs) | |
| Transport | Length | 19.4m (63' 8") |
| | Height | 3.07m (10' 1") |
| | Width | 2.75m (9') |
| Working @ 24° | Length | 25.5m (83' 7") |
| | Height | 10.5m (34' 6") |
| | Width | 2.75m (9') |
| Power Unit | Tier 3: CAT 4.4 83kW (111hp) or, Tier 4F: CAT 4.4 82kW (110hp) or, Stage V: CAT 3.6 82kW (110hp) | |

NOTE: Dimensions may differ slightly from sales drawings due to differences in angles / reference points.

FEATURES & BENEFITS

- High capacity up to 600tph (661 US tph).
- Maximum feed size up to 150mm (6").
- Radio remote control to stop / start feeder, raise / lower conveyor, slew & track machine.
- Eliminates the need for wheeled loaders to create stockpiles - reduces labour and maintenance costs.
- Eliminates the need for handling material multiple times - reduces labour and maintenance costs.
- Improved material quality due to reduced compaction, degradation, segregation and contamination.
- Can accept loads from an excavator, wheeled loader, crusher or screener.
- Multiple hopper options available depending on required capacities and operators loading methods or application.
- Rapid set up time and manoeuvrability around site.
- Reduced fuel consumption due to reduced reliance on wheeled loaders.
- Reduced wear on wheeled loaders where a conveyor is utilised.
- Hydraulic discharge height adjustment.
- Hydraulic fold over for transport.
- Rosta scraper.
- Kick out sensor stops feeder if discharge belt is under extreme load.
- Pinless deployment.
- Discharge conveyor head drum bearing automatic greasing.
- External conveyor belt adjustment.
- Engine pre-start delay & siren.
- Emergency stops x 3.

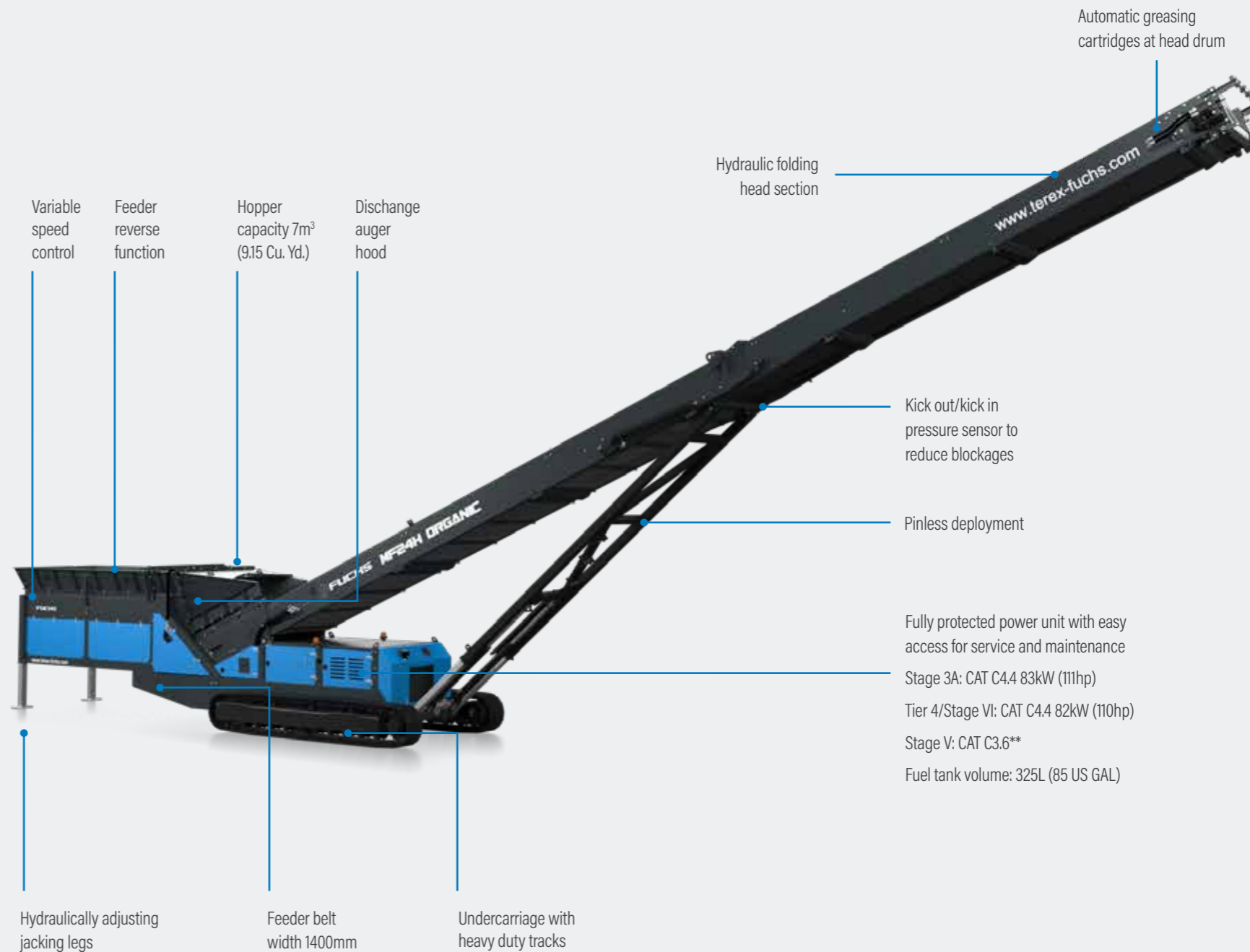

MF24H ORGANIC FEEDER



HOPPER

| | |
|------------------------------------|----------------------------------|
| Target Area: | 4040mm (13' 3") x 2000mm (6' 7") |
| Capacity (No Tipping Grid Fitted): | 10m ³ (13 Cu.Yd.) |
| Rear Feed In Height: | 3.52m (11' 6") |

FEED CONVEYOR

| | |
|------------------|--------------|
| Width: | 1400mm (56") |
| Belt Type: | Plain |
| Belt Spec: | EP400/3 4+2 |
| Variable Speed: | Yes |
| Auger Max Speed: | 195rpm |

DISCHARGE CONVEYOR

| | |
|--|---------------------------------|
| Width: | 1200mm (48") |
| Belt Centres: | 22.5m (73' 10") |
| Belt Type: | Chevron |
| Belt Spec: | EP315 3 3+1.5 |
| Drive Drum Dia: | 345mm (13.6") |
| Tail Drum Dia: | 320mm (12.6") |
| Max Belt Speed: | 113m/m |
| Motor Size: | 630cc |
| Operating Angle: | 5° - 24° |
| Discharge Height @18°: | 8m (26' 3") |
| Stockpile Capacity @18° & 37° Angle of Repose: | 944m ³ (1235 Cu.Yd) |
| Discharge Height @24°: | 9.8m (32' 2") |
| Stockpile Capacity @24° & 37° Angle of Repose: | 1735m ³ (2270 Cu.Yd) |
| Variable Speed: | Yes |

TRACKS

| | |
|------------------|-------------------|
| Shoe Width: | 400mm (1' 4") |
| Sprocket Centre: | 4300mm (14' 1") |
| Outer Width: | 2750mm (9') |
| Gradability: | 45.9° |
| Speed: | 0.6km/h |
| Speed High: | 1.1km/h |
| Speed High: | 68Lpm (Per track) |



POWER UNIT & HYDRAULICS

| | |
|------------------|--------------|
| Engine (Tier 3): | CAT C4.4 |
| Power Rating: | 83kW (111hp) |
| RPM: | 1800rpm |
| Crankshaft Pump: | 38/38/8 |

| | |
|-------------------|--------------|
| Engine (Tier 4F): | CAT C4.4 |
| Power Rating: | 82kW (110hp) |
| RPM: | 1800rpm |
| Crankshaft Pump: | 38/38/8 |

| | |
|-------------------|--------------|
| Engine (Stage V): | CAT C3.6 |
| Power Rating: | 82kW (110hp) |
| RPM: | 1800rpm |
| Crankshaft Pump: | 38/38/8 |

| | |
|-----------------------------|------------------|
| Diesel Tank Capacity: | 325L (86 US GAL) |
| Hydraulic Tank Capacity T3: | 360L (95 US GAL) |
| Hydraulic Tank Capacity T4: | 360L (95 US GAL) |

OPTIONS

- Canvas dust covers on discharge conveyor.
- Feedboot lined with 6mm AR400 wear plate
- Canvas dust covers complete with dust hood on discharge conveyor.
- Dust hood
- Twin drive discharge conveyor (recommended to also select ceramic drive drum option).
- Twin drive feed conveyor.
- Anti-roll back flaps.
- Heavy duty discharge belt EP500 4 ply x 8 + 2 covers.
- High spec scraper on discharge conveyor (plain belt only).
- Ceramic lagging on discharge conveyor drive drum.
- Ceramic lagging on feed conveyor drive drum.
- Discharge conveyor under guard for mid-section.
- Dust suppression (spray bars only).
- Belt weigher.
- Full length skirting rubber on discharge conveyor.
- Grease lines to head drum.
- Overband magnet on discharge conveyor with hydraulic kit and support frames.
- Radio remote to start / stop feeder, raise / lower discharge conveyor.
- Radio remote for tracking machine only.
- Grade ISO 86 Hydraulic oil (Recommended for ambient temperatures between +15 and +50 degrees Celsius).
- Pull cord E-Stop running the length of the conveyor.
- Hybrid configuration.



MF24H ORGANIC FEEDER

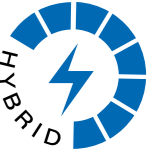

WORKING DIMENSIONS

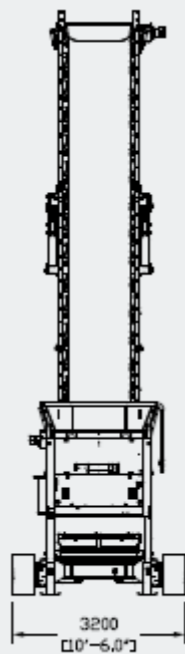
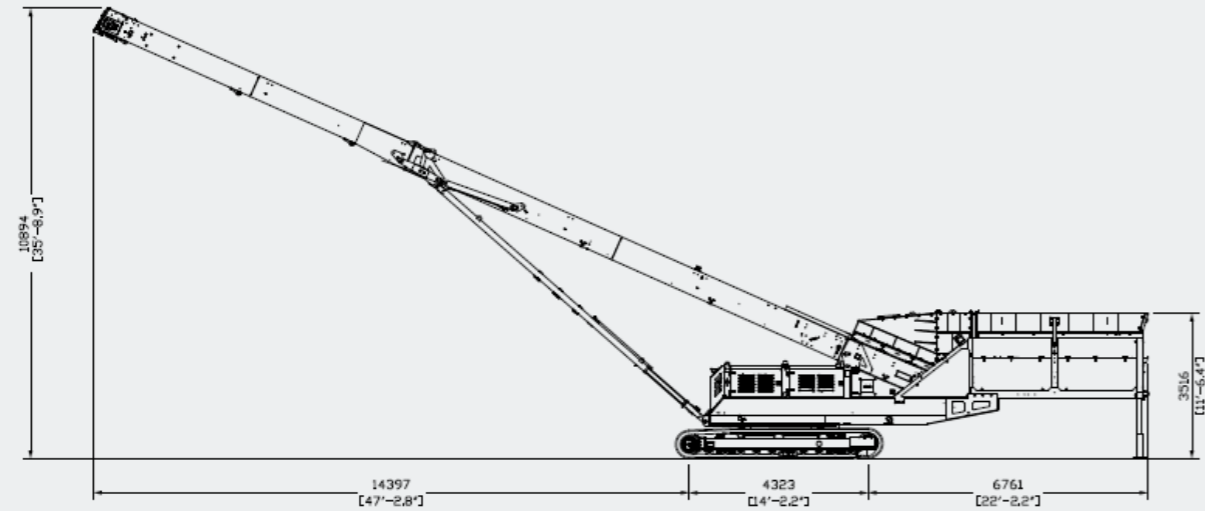

TRANSPORT DIMENSIONS

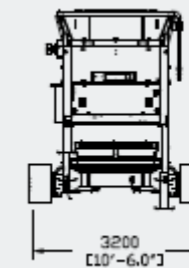
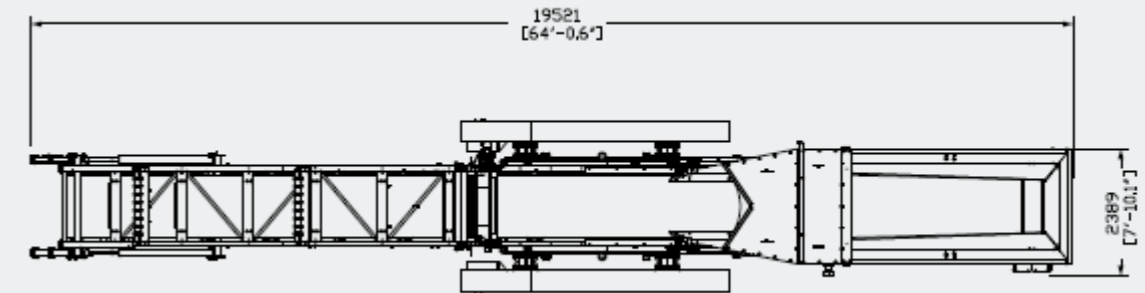
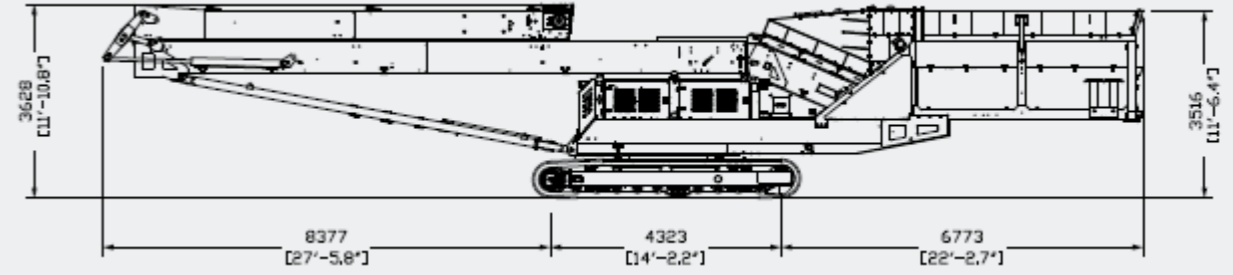



FUCHS[®]

A TEREX BRAND

WORKS FOR YOU.[™]

www.terex-fuchs.com

August 2021. Product specifications and prices are subject to change without notice or obligation. The photographs and/or drawings in this document are for illustrative purposes only. Refer to the appropriate Operator's Manual for instructions on the proper use of this equipment. Failure to follow the appropriate Operator's Manual when using our equipment or to otherwise act irresponsibly may result in serious injury or death. The only warranty applicable to our equipment is the standard written warranty applicable to the particular product and sale and Terex makes no other warranty, express or implied.

© Terex Corporation 2021. Terex, the Terex Crown design, Fuchs and Works For You are trademarks of Terex Corporation or its subsidiaries.

Terex Deutschland GmbH | Industriestraße 3 | 76669 Bad Schönborn | Germany | Phone: +49 (0) 7253 84-0 | Fax: +49 (0) 7253 84-102 | Email: info.terex-fuchs@terex.com