

**FR17 C**  
**PICK AND CARRY**  
**CRANE**



MAXIMUM RATED CAPACITY  
**17 t**



MAXIMUM BOOM LENGTH  
**18.23 m** (manual extension)  
**20.83 m** (with fly jib)



MAXIMUM TIP HEIGHT  
**20.4 m** (with fly jib)



STABILITY  
**66.5%**



**Clutch Free Operation**



# OVERVIEW

The FR17 C is a very compact pick and carry mobile crane from Franna product range specially designed for higher lifting capacity applications (17 Tonne). This 4WD crane has a powerful Tier-III emission compliance engine, synchro shuttle transmission and heavy-duty axles that makes it versatile for all types of crane application.

This machine has a large torque converter, there is no clutch pedal which reduces driver fatigue while working for long crane hours. This crane combines safety and comfort with smooth steering flexibility, providing the operator with the ability to lift and manoeuvre in tight spaces. The heavy-duty U section fabricated boom with welding on the neutral axis offers superior durability and a competitive edge while lifting heavy loads.



**Double Cabin**



**5T Winch**



**Lowest Turning Radius**



**4x4**



**10 Bolt Carraro Axle**



**Torque Converter**



**5 Hook Positionings**



**U-Section Boom**



# TECHNICAL DESCRIPTION

## 01. Boom

Maximum boom length (manual extn.)	18.23 m
Maximum boom length (fly jib)	20.83 m
Maximum tip height (fly jib)	20.4 m
Boom elevation angle range	-5°/60°
Articulation	40° R / 40° L
Fixed lug	17 tonne
Machinery hook (rhino)	8 tonne

## 02. Winch

Maximum line pull	5 tonne
Winch Maximum Speed	48 m/min
4 Part Hook block	10.5 tonne max rated capacity, fully compensated hook height whilst telescoping the boom

## 03. Engine & Transmission

Standard engine	Cummins QSF3.8 EU Stage IIIA
Engine power	86 kW (115 hp) @2200 rpm
Engine torque	470 Nm
Fuel Type	Diesel
Fuel Capacity	270 litre
Transmission	Carraro 4 Speed Synchro shuttle
Torque Converter	SACHS 2.64 ratio

## 04. Hydraulic System

High Pressure Vane pump	46 cc/rev
Maximum pump flow rate	110 litre/min
Maximum working pressure	220 bar
Hydraulic Oil	175 litre

## 05. Axle Loadings & Turning Radius

Front Axle	6600 kg
Rear Axle	10200 kg
Total*	16800 kg
Turning Radius	6.77 m
Ground Clearance	325 mm

## 06. Brakes

Brake System	Hydraulic Disc Brake
--------------	----------------------

## 07. Tyres & Rims

Front	11.00x20-18PR dual tires, 8x20 (10 stud) rims
Rear	11.00x20-18PR dual tires, 8x20 (10 stud) rims

## 08. Electricals

System	12V DC
--------	--------

## 09. Steering

Steering	Full power orbitrol with twin cushioned double acting rams with 40 deg articulation either side
----------	---

## 10. Vehicle Performance & Drive

Max Speed	42 km/h
Gradeability	33% (laden), 50% (unladen)
Drive	4x4



**Options available at additional cost:** Outrigger, Safe Load Indicator (SLI), Fly Jib, Man Basket, AC Cabin, USB Player, Reverse Camera, Drag Winch, Safety Grill, Crash Guard, Rhino Hook, Beacon Light, Extra Hook, Water tank for Wiper, Telematics.

\*Weight shown above is with accessories. Actual weight may change as per accessories selection.

# DIMENSIONS / AREA OF OPERATION

## Plan view

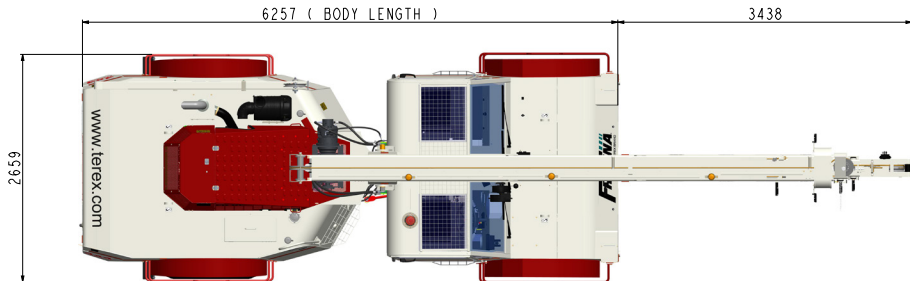

## Right hand view

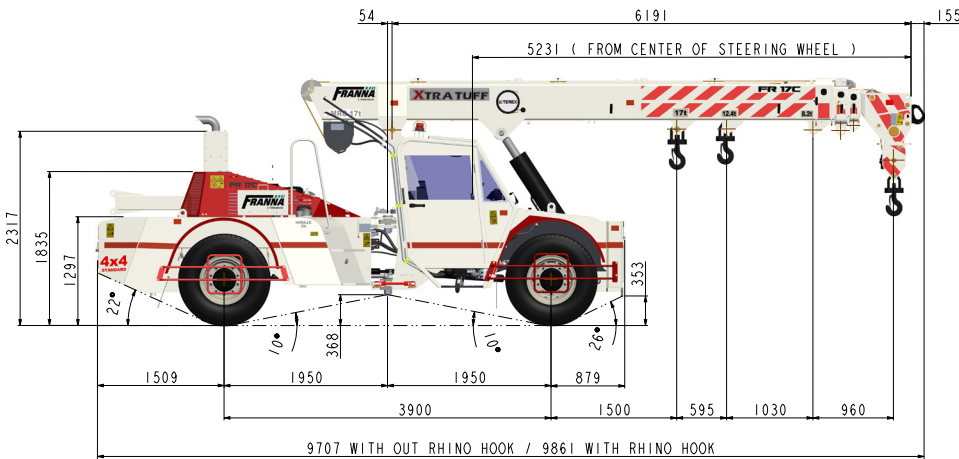

## Front view

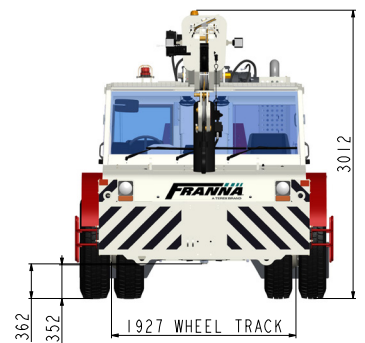

## Area of operation

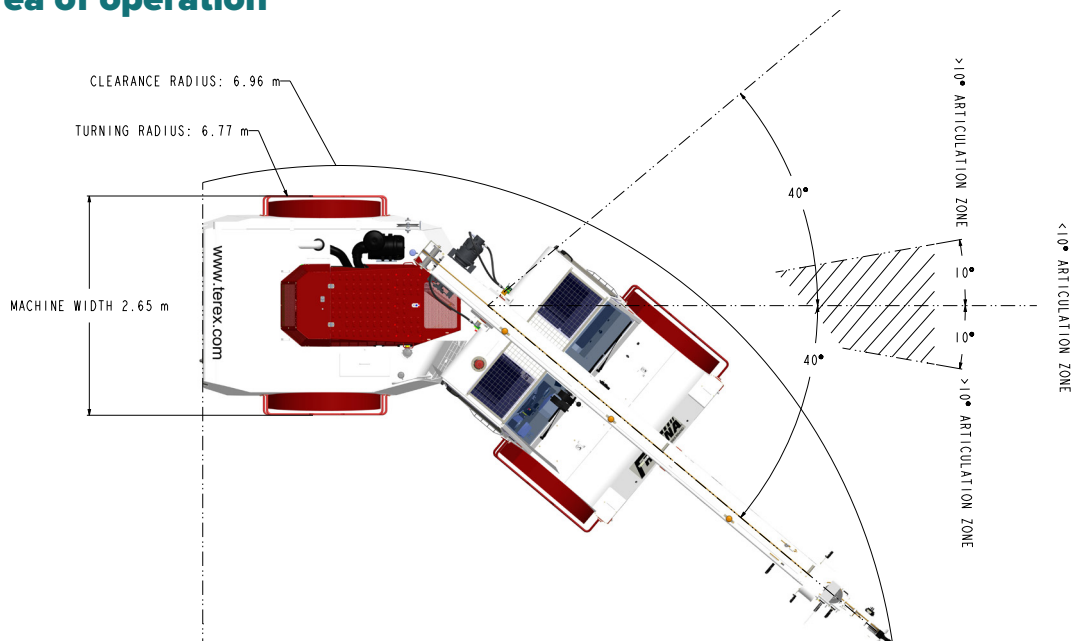



# RADIUS LOAD CHART

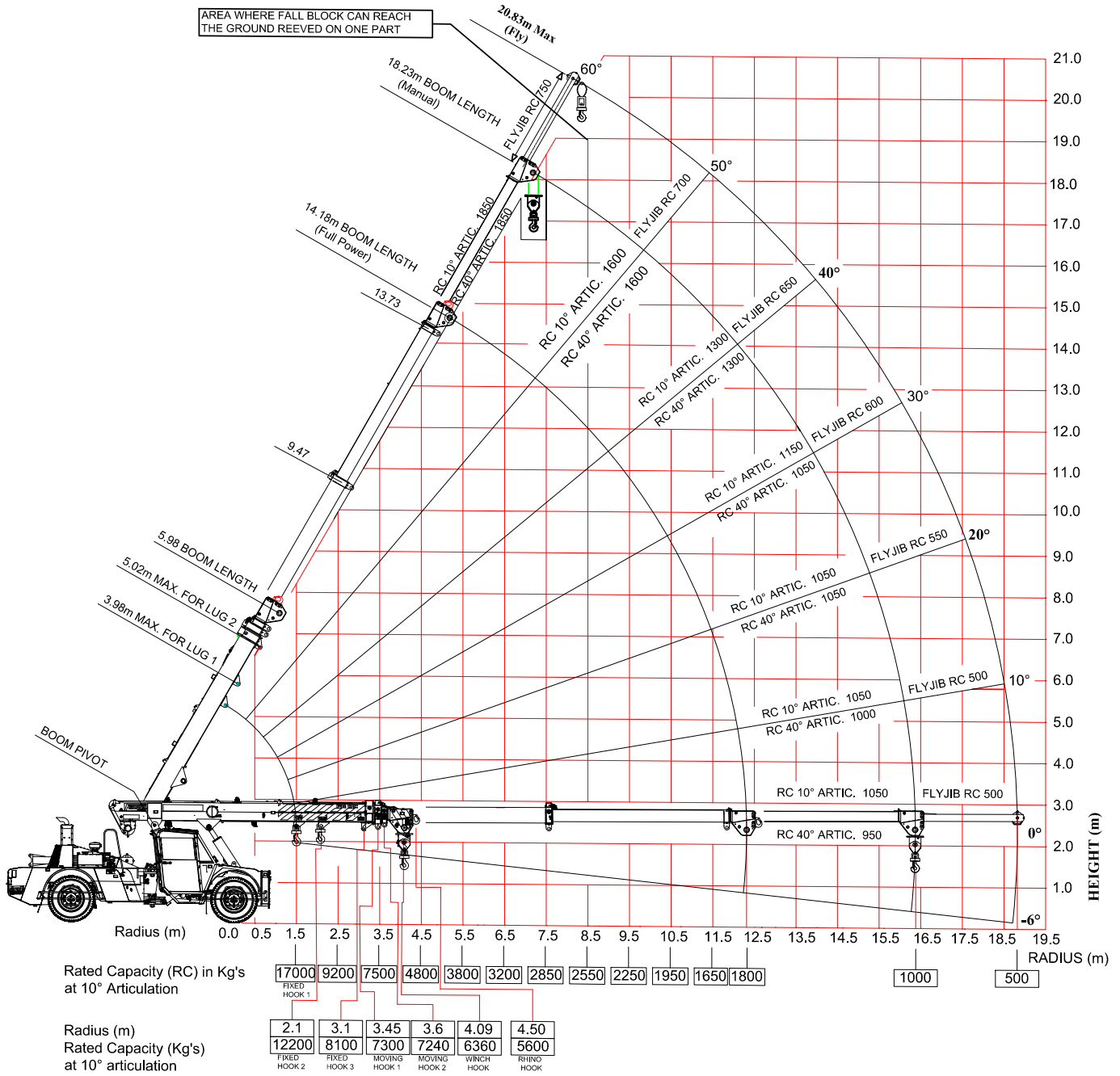

## Note:

- Rated Capacity values shown are for the Pick and Carry Chart.
- Rhino Hook & Fly Jib shown are provided as per customer request.
- Rope Ø13mm & Min breaking force ≥145kN

# LOAD CHART

RATED CAPACITY CHART - LIFTING ON WINCH FALL BLOCK																			
RADIUS	BOOM LENGTH (m)																		
	5.98	6.50	7.00	7.50	8.00	8.50	9.00	9.50	10.00	10.50	11.00	11.50	12.00	12.50	13.00	13.50	14.00	14.18	
1.5	9700	10500																	
	9700	10500																	
	56	59																	
2.0	9400	9700	10500	10500															
	9400	9700	10500	10500															
	49	53	56	59															
2.5	9200	9300	9500	9700	10500	10500													
	9200	9300	9500	9600	9600	9600													
	43	48	51	54	57	59													
3.0	8900	8900	8900	8900	8900	8900	8900	8800											
	7900	7900	7900	7900	7900	7900	7900	7900											
	35	41	46	49	53	55	57	59											
3.5	7500	7500	7500	7500	7500	7500	7500	7500	7500										
	6600	6600	6600	6600	6600	6600	6600	6600	6600										
	26	34	40	44	48	51	54	56	58	60									
4.0	6400	6400	6400	6400	6400	6400	6400	6400	6400	6400	6200	5500							
	5700	5700	5700	5700	5700	5700	5700	5700	5700	5700	5700	5500							
	10	25	33	38	43	46	49	52	54	56	58	60							
4.5	6200	5600	5600	5600	5600	5600	5600	5600	5600	5600	5600	5200	5000	4800					
	5500	5900	5000	5000	5000	5000	5000	5000	5000	5000	5000	5000	5000	4800					
	(4.09)	10	24	32	37	42	45	48	51	53	55	57	58	60					
5.0		5400	4900	5000	5000	5000	5000	5000	5000	5000	5000	4800	4600	4500	4300	4200			
		4800	4400	4400	4400	4400	4400	4400	4400	4400	4400	4400	4400	4400	4300	4200			
		(4.60)	10	23	31	36	40	44	47	49	52	54	56	57	59	60			
6.0			4800	4300	4000	4000	4000	4000	4000	4000	4000	4000	4000	3900	3800	3700	3400	3400	
			4200	3800	3500	3500	3500	3500	3500	3500	3500	3500	3500	3500	3500	3500	3400	3400	
			(5.10)	(5.60)	10	22	29	34	38	42	45	47	50	52	53	55	57	57	
7.0					3900	3500	3300	3300	3300	3300	3300	3300	3300	3300	3300	3200	3100	3000	
					3400	3100	2900	2900	2900	2900	2900	2900	2900	2900	2900	2900	2900	2900	
					(6.10)	(6.60)	9	21	28	33	37	40	43	45	48	50	51	52	
8.0							3200	3000	2800	2800	2800	2800	2800	2800	2800	2800	2800	2700	
							2800	2600	2400	2400	2400	2400	2400	2400	2400	2400	2400	2400	
							(7.10)	(7.60)	9	20	26	31	35	38	41	44	46	47	
9.0									2700	2500	2400	2400	2400	2400	2400	2400	2400	2400	
									2400	2200	2000	2100	2100	2100	2100	2100	2100	2100	
									(8.10)	(8.60)	8	19	25	30	34	37	40	41	
10.0											2300	2200	2000	2100	2100	2100	2100	2100	
											2000	1900	1800	1800	1800	1800	1800	1800	
											(9.10)	(9.60)	8	19	25	29	33	34	
11.0													2000	1900	1800	1800	1800	1800	
													1700	1600	1500	1500	1500	1500	
													(10.10)	(10.60)	8	18	24	25	
12.3																1800	1600	1500	1500
																1500	1400	1300	1300
																(11.10)	(11.60)	(12.10)	(12.28)

**KEY:**

- SWL (KG) LESS THAN 10 DEG ARTICULATION
- SWL (KG) GREATER THAN 10 DEG ARTICULATION
- BOOM ANGLE OR (RADIUS AT 0 DEG BOOM ANGLE)

Note: Weight of slings & hook block to be added to load  
 Read and understand warning notes before operating crane  
 Load Chart calculations are based on 66.5% stability rating

# FEATURES & ATTACHMENTS



## NEUTRAL AXIS WELDING BOOM

Latest boom technology for Heavy duty applications. U section ensures higher lifting capacity with longer life

## COMPACT MACHINE

Shortest Turning radius of 6.7 meter makes it ideal machine for City and congested areas.

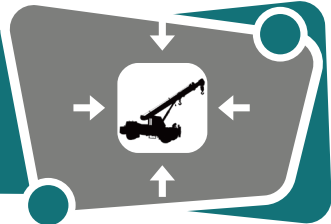

## WINCH MOUNTING

Under boom winch ensures safe operations while working in compact area. Ideal for city and industrial applications

## 66.5% STABILITY

Higher safety and stability reduces the chances of accident.

# 66.5%



## SINGLE LUFF CYLINDER

Increases the visibility and reduces the maintenance.

## TELEMATICS

24X7 machine update on location, health and performance on one click

\*Optional Attachment

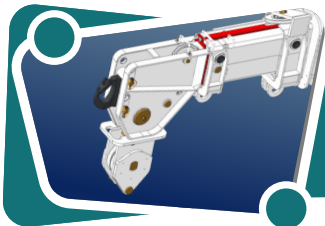

## MANUAL EXTENSION ROD

Quick and reliable mechanism for higher height applications

## MAN BASKET

250 Kg capacity with Self leveling mechanism

\*Optional Attachment

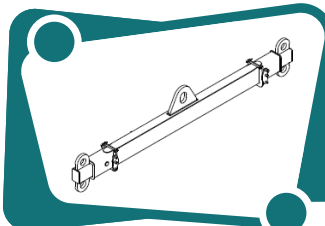
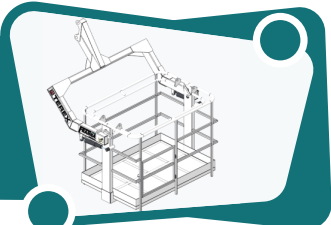

## SPREADER BAR

Ideal for oversize load lifting application. Helpful for pipe, steel bars lifting

\*Optional Attachment

# OUR LOCATIONS



## South: Hosur Plant

Terex India Private Limited  
Plot No : E-18, Expansion-II, Phase-II  
SIPCOT, Krishnagiri Road  
Hosur - 635 109, Tamil Nadu  
**Tel:** +91 4344 352 200

---

**Dealer Stamp:**

---

## Brisbane

Terex Australia Pty Ltd  
585 Curtin Avenue East (PO Box 1396)  
Eagle Farm QLD 4009, Australia  
**Tel:** +61 7 3868 9600

**Email:** [franna@terex.com](mailto:franna@terex.com)



Follow us on  
**LinkedIn**

The information contained in this leaflet is intended to be of general nature.  
Terex Corporation reserves the right to change the specifications without prior notice.  
All dimensions and weights are variable within  $\pm 5\%$

Published and Printed in June 2023



[www.terex.com/franna](http://www.terex.com/franna)

