

TC-80

CONVEYOR



STRONG **HERITAGE**, STRONG **FUTURE**

 **FINLAY**[®]
A TEREX BRAND

TC-80

CONVEYOR



The Finlay® TC-80 mobile stockpiler is a highly mobile and flexible machine that offers operators an efficient, reliable and cost-effective stockpiling solution. The robust machine has been engineered for flexibility across a range of applications and features variable belt speed, adjustable feed height and variable discharge height.

Whether it is aggregate production, sand and gravel, recycling or waste management applications the integration of the TC-80 can reduce fuel, maintenance and labour costs by up to 80% and ensure consistency in quality of stockpiled materials.

FEATURES:

- › Inbuilt safety measures engineered into the machine include hydraulic feed height adjustment of the feedboot and pinless deployment of the main conveyor.
- › Tracked mobility enables easy onsite redeployment and the machine can be transferred easily between locations on standard low loader trailer or packed in 1 x 40ft container for shipping throughout the world.
- › The machine is available with hybrid technology consisting of on-board electrical motors permitting the flexibility to run the plant from an outside power supply or standard on-board engine.
- › The machine features a 22.8m (74' 10") product conveyor that has the capacity to transfer up to 400tph of material.
- › Maximum conical stockpile capacity based on 37° angle of repose: 3328 tonnes (3668 US tph).

TRANSPORT DIMENSIONS

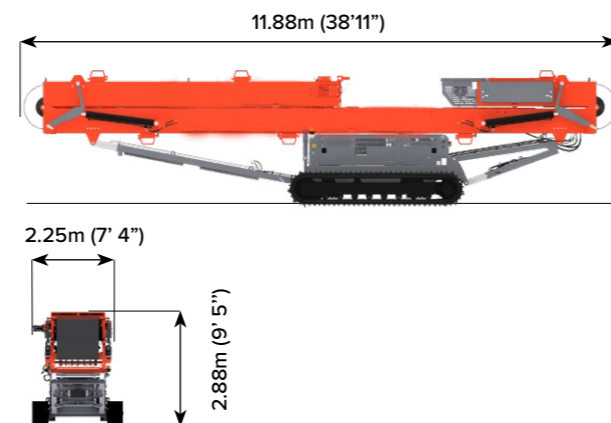

WORKING DIMENSION



MACHINE WEIGHT: 16,750kg (36,927 lbs)

1 FEEDBOOT

Standard: 0.6m³ (0.8yd³)
Extended: 1.6m³ (2.1yd³)
Biomass Option: 5.24m³ (6.8yd³)

2 MAGNET (OPTION)

Overband magnet option complete with hydraulic kit and support frame

3 UNDERCARRIAGE

Shoe Width: 400mm (1' 4")
Sprocket Centers: 4000mm (13' 1")
Speed: 0.9km/h (0.56mph)

4 HYBRID TECHNOLOGY

The machine is available with hybrid technology consisting of on-board electrical motors permitting the flexibility to run the plant from an outside power supply or standard on-board engine.

5 SAFETY FEATURES

Inbuilt safety measures engineered into the machine include hydraulic feed height adjustment of the feedboot and pinless deployment of the main conveyor

6 STOCKPILE CAPACITY

Maximum conical stockpile capacity based on 37° angle of repose: 3328 tonnes (3668 US tph).



T-LINK TELEMATICS

T-Link telematics hardware and software along with free seven year data subscription are fitted and installed as standard.



REDUCED COST



SITE OPERATING EFFICIENCY



ENVIRONMENTAL CONSIDERATIONS



IMPROVE HEALTH & SAFETY



PRODUCT QUALITY



The material in this document is for information only and is subject to change without notice.

Finlay® assumes no liability resulting from errors or omissions in this document, or from the use of the information contained herein.

Due to continual product development we reserve the right to change specifications without notice. Product performance figures given in this brochure are for guidance purposes only, this information does not constitute an expressed or implied warranty or guarantee, but shows test examples. These results will vary depending on application. Photographs are for illustrative purposes only; some or all of the machines in the illustrations may be fitted with optional extras. Please check with your Dealer for details on optional extras.

Published and Printed in 2023

www.terex.com/finlay

E: sales@terexfinlay.com

T: +44 28 82 418 700

