

VACRECOVER[™] RANGE



Recover, Repurpose and Reuse

Recycle your HydroVac, Road
Sweepings and Gully Waste material
into a saleable material

AGGREGATES 

RECYCLING 

SANDS 

WATER TREATMENT 

The VacRecover range is a static machine capable of processing wet waste such as Hydrovac, Road Sweepings & Gully waste. A cost and energy efficient machine on a single compact chassis.

The VacRecover range is designed for solids/liquids separation for producing a clean dewatered oversize product and a clean dewatered sand product.

FEATURES & BENEFITS

- Large capacity Reception Hopper suitable for up to 6 tanker trucks per hour.
- C/W Grid bars, washdown spraybars, walkways and remote HMI controls.
- Under flow controlled by automatic proportional valve
- Multiple hopper options available.

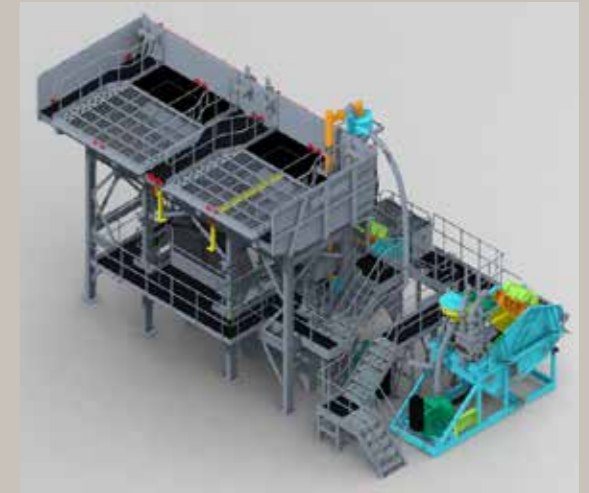

Model Pictured: VR 60L c/w additional Fines Recovery system

- Linatex rubber-lined high efficiency Separators provides maximum silt and clay (-75µm/200mesh) removal from the final product.
- Choice of Separators available depending on the duty.
- Replaceable drop-in liners.

- Ultrasonic tank level control system ensures consistent tank volume and pump run-dry protection.
- All slurry pipework is rubber lined.

- Available wired to isolators or with an optional control panel.
- Optional mechanism for controlling up to 2 stockpile conveyors.



- Linatex Rubber-lined centrifugal pumps with replaceable liners.
- Easy access for all pump and motor maintenance.
- Integrated support arm for ease of maintenance when opening the pump casing.

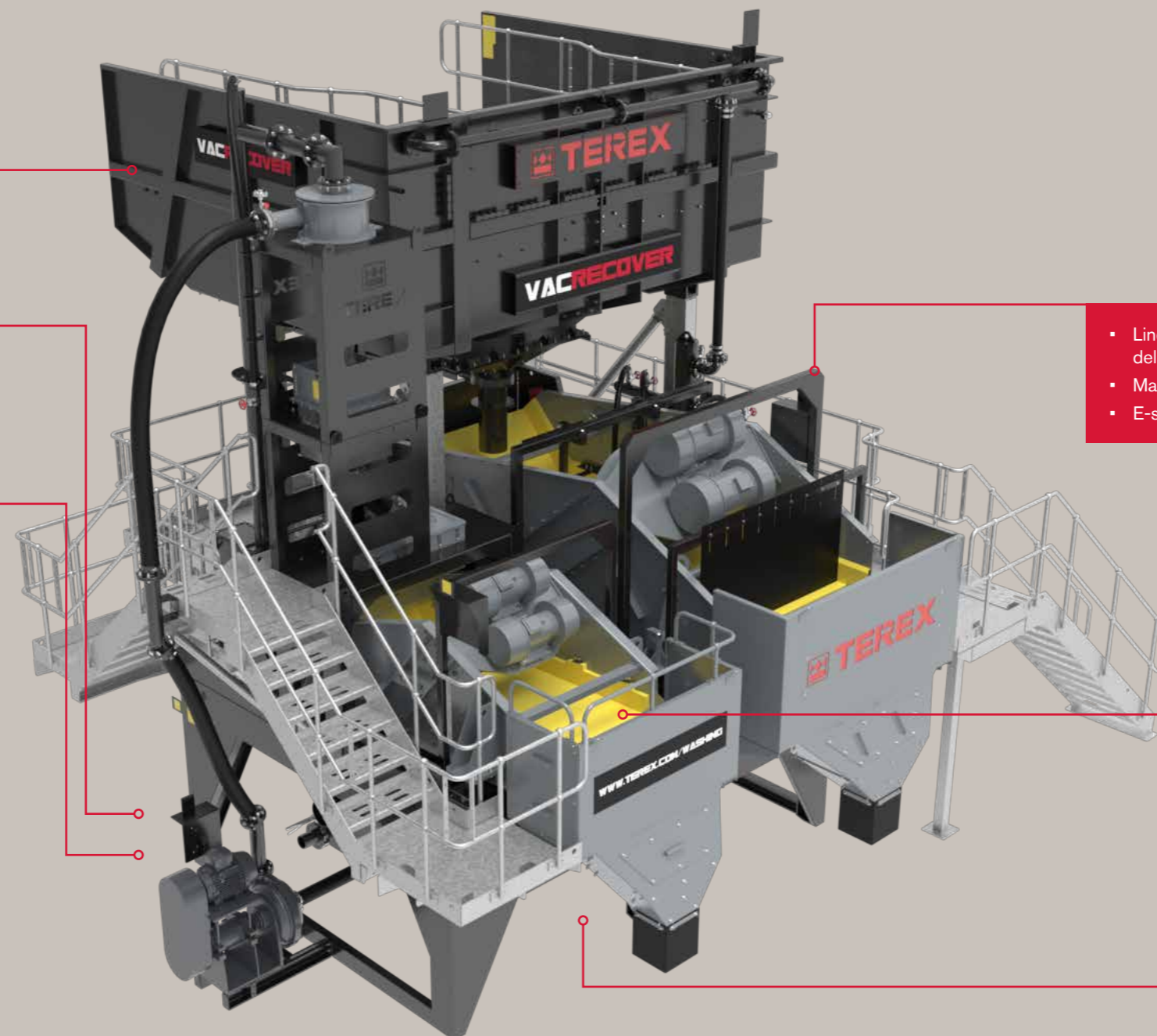

- Linear motion, high frequency dewatering screens delivering superior moisture reduction.
- Marshmallow vibration isolation screen mountings.
- E-stops located all around the plant for safe operation.

- Full-width modular polyurethane dewatering media for quick change outs.
- Polyurethane side modules for increased screen protection.
- Fully lined low friction discharge chutes.

- Fully galvanised walkways allowing comprehensive access to the plant.
- Raised chassis design for machine wash down.
- Sloped tank reduces the risk of fines build up.

Model Pictured: VR 60

VACRECOVERTM RANGE

APPLICATIONS

The VacRecover range can produce a clean aggregate and sand from the process slurry produced during hydro excavations.



OPTIONS

The VacRecover range can be offered with the following options:

- Multiple hoppers
- Electrical control panels with starters for product conveyors
- Dewatering screen spraybars
- Cyclones or Separators
- Customized build to double wash dirty material

COMPONENTS

The VacRecover range share the following features:

Cyclone/Seperator

- Application specific sizes
- Spigot or fish tail discharge
- All wear areas rubber lined
- Pressure flange with gauge and protector

Centrifugal Pumps

- Sized to suit your needs, with numerous combinations of pump and motors
- Abrasion resistant liners
- Moulded rubber impellers
- Pump drain for cold climate applications
- Excellent serviceability

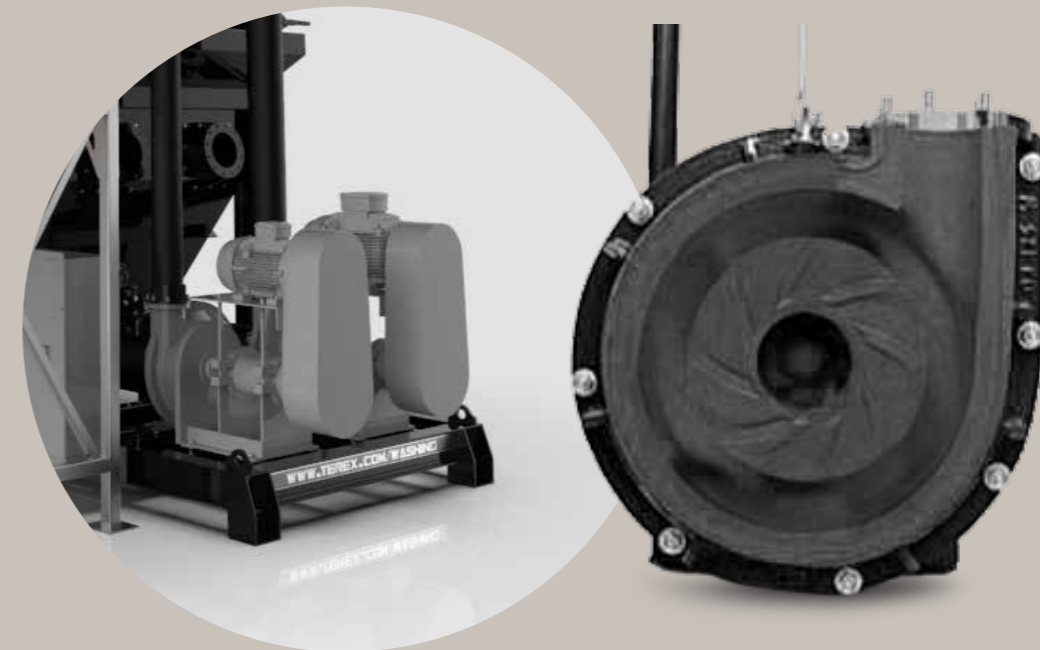

COMPONENTS

Chassis

- Ultrasonic tank level control system ensures consistent tank volume and pump run-dry protection
- Built in anti-turbulence feed sections
- Heavy duty steel construction
- Easy access to all serviceable areas

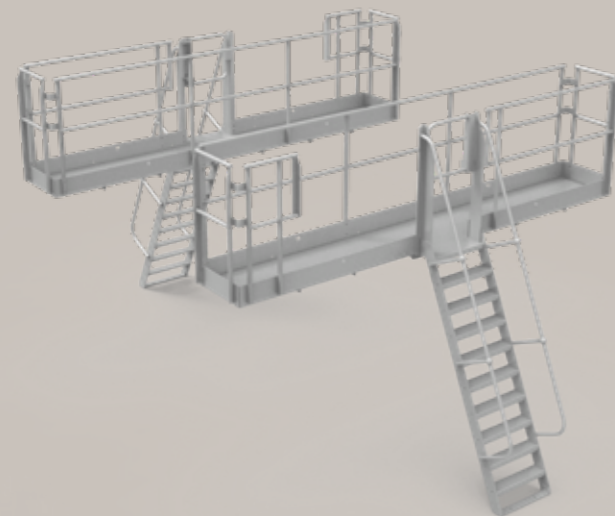

Access

- Fully galvanised walkways
- Access to all serviceable areas

Screens

- Exceptional dewatering performance
- Heavy duty frame suitable for surge loading
- Optional Spray bars
- From 6x2 to 14x6
- 2 x vibratory motors
- Polyurethane modules and side protection
- Polyurethane low friction chute liners
- Marshmallow screen mounts for smoother running

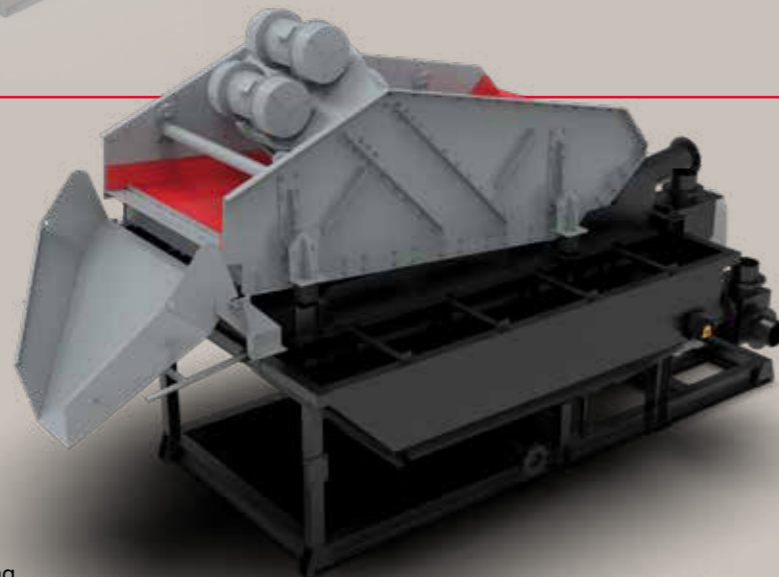

The VacRecover is highly configurable, with a large choice of screen sizes, tank and pump volumes, cyclone/separators, and multiple Hoppers. Below are some sample data for single and twin hopper variants.



Model Pictured: VR 60

Model Variant: VR 60	
Feed Rate	Up to 60tph Dry Feed (Process Rate)
Trucks Per Hour	4 x 10m ³ Vacuum Tankers Per Hour
Max Piece Size in Feed Material	Max 100mm
Max Washed Aggregate Production	Max 30tph
Max Washed Sand Production	Max 30tph
Typical Water Requirements	130m ³ /hr
Typical Electrical Requirements	32KW

TRANSPORT

The VacRecover range are designed to fit standard shipping containers in the most cost effective way:

Machine Model	Container requirement
VR 60	3 x 40' 1 x 20'
VR 90	4 x 40' 1 x 20'

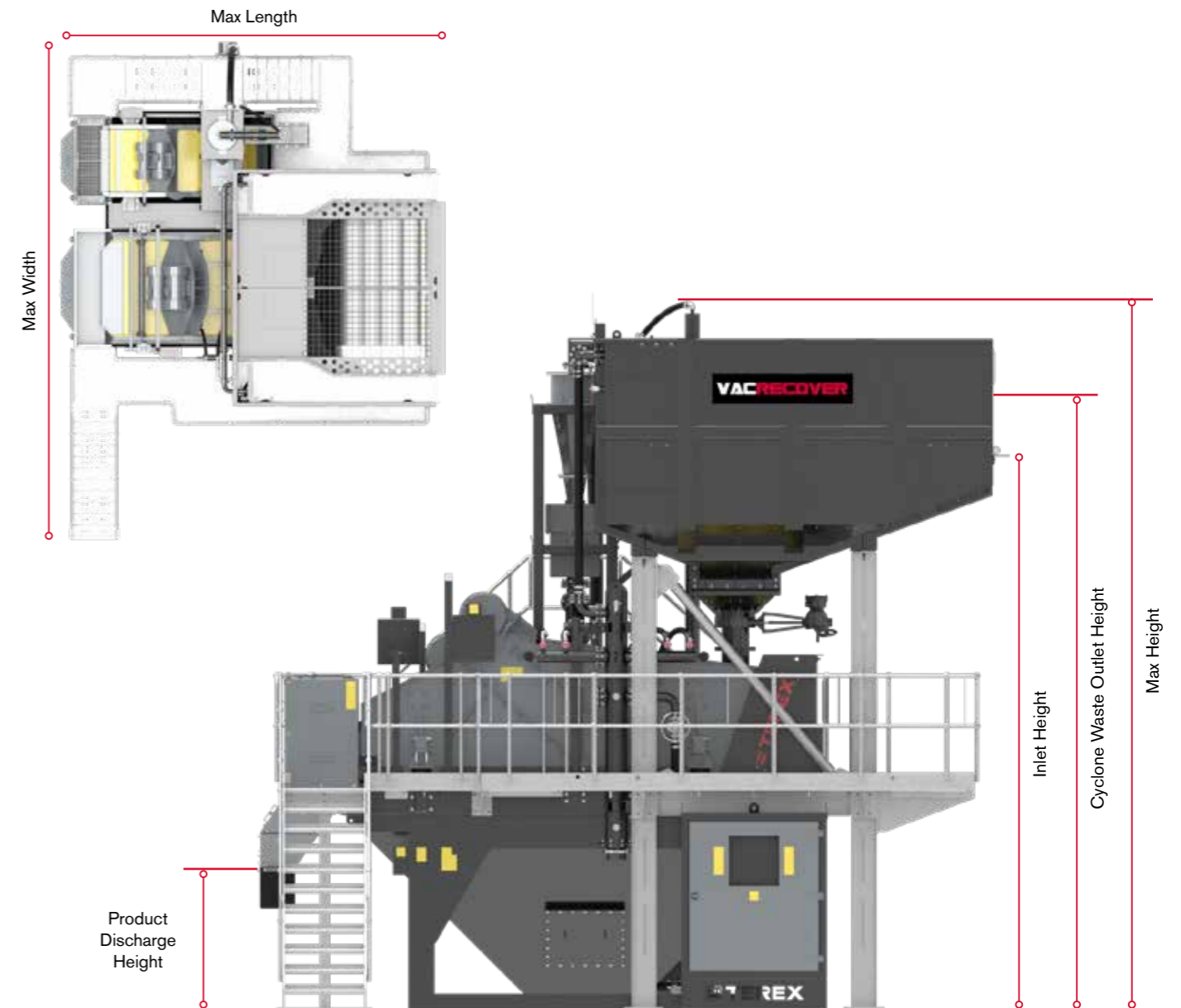
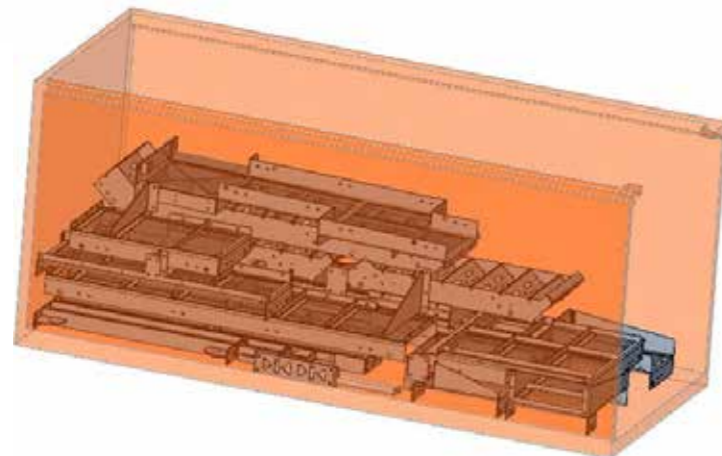
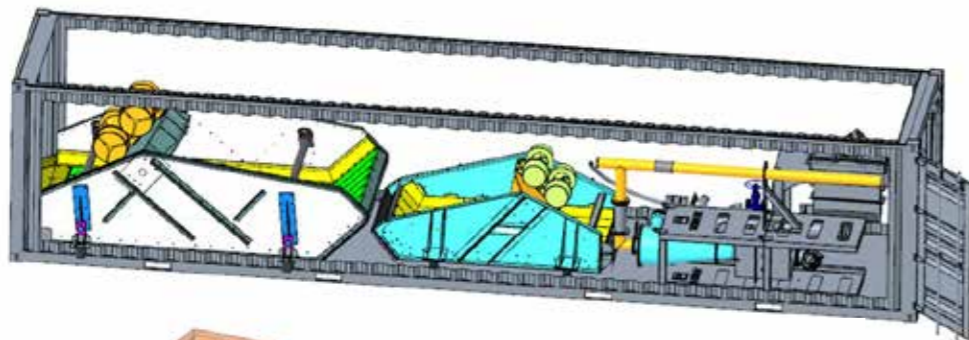
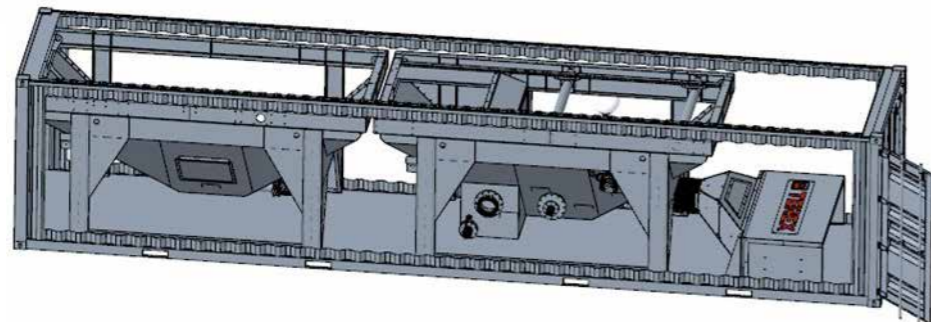
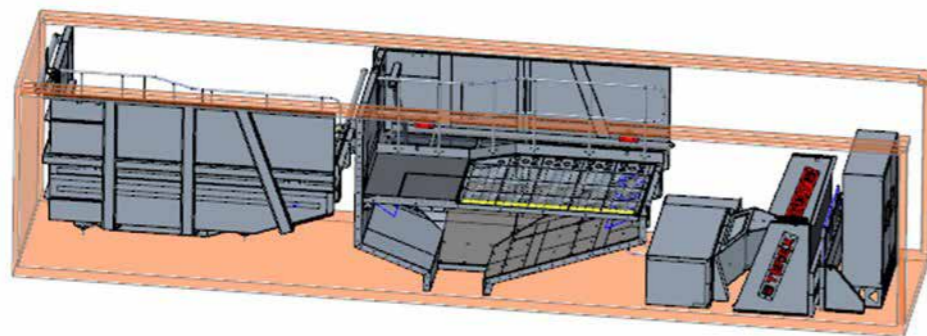

Machine Model	VR 60	VR 90
Max Height	7040 (23'1")	7040 (23'1")
Max Length	7300 (23'11")	7300 (23'11")
Max Width	9670 (32')	9670 (32')
Inlet Height	5100 (16'8")	5100 (16'8")
Cyclone Waste Outlet Height	6660 (21'10")	6660 (21'10")
Discharge Height	1350 (4'5")	1350 (4'5")

Dimensions VR range. Units: Metric-mm [Imperial].



WASHING AS IT SHOULD BE



CHECK OUT TEREX WASHING SYSTEMS
VIDEOS ON YOUTUBE:
www.youtube.com/terexwashingsystems

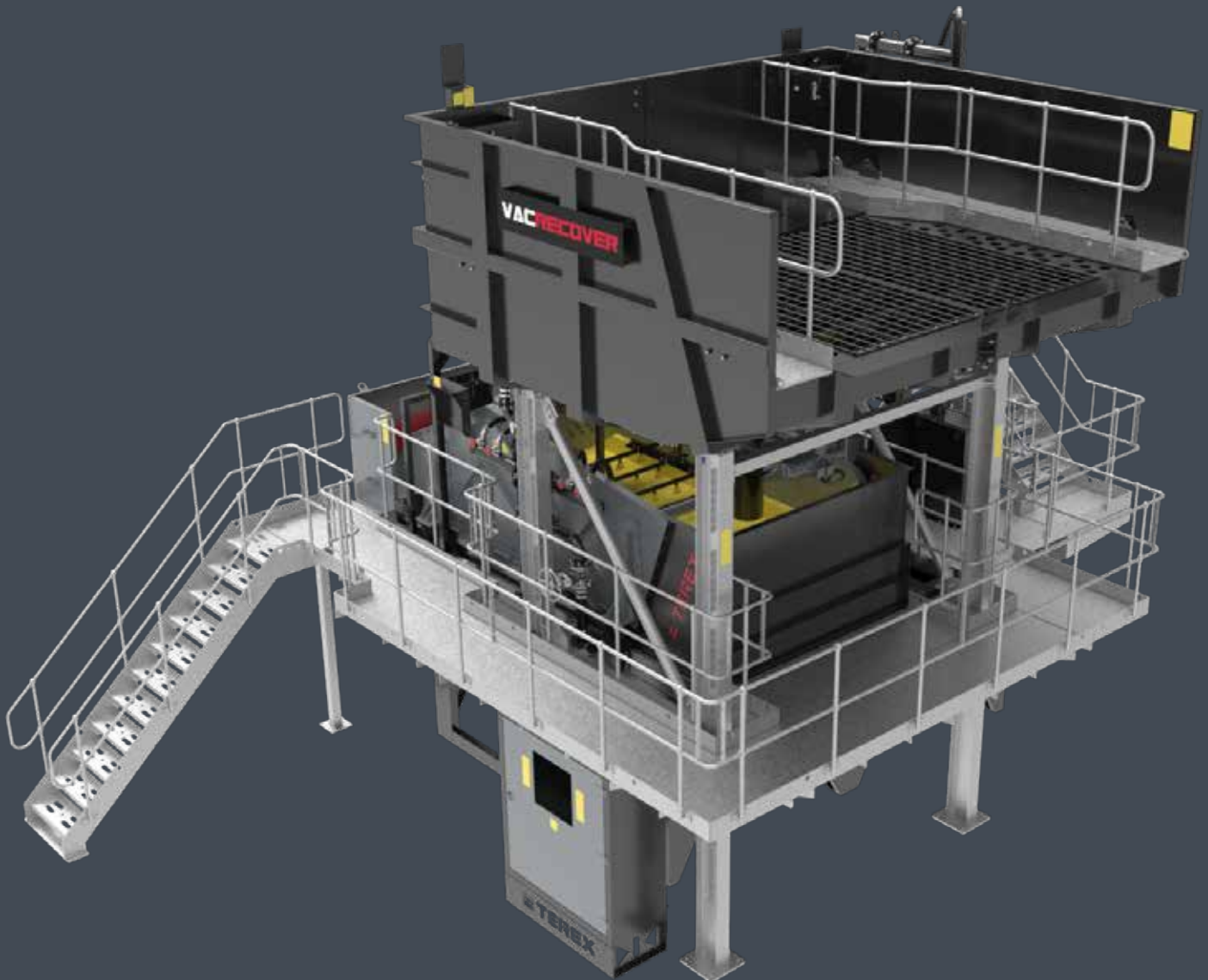

TEREX WASHING SYSTEMS

FARLOUGH SITE

32 Farlough Road,
Dungannon,
Co. Tyrone,
Northern Ireland, BT71 4DT

Tel: +44(0) 28 8771 8500
Email: TWS.sales@terex.com

www.terex.com/washing

Effective Date: March 2023 Product specifications and prices are subject to change without notice or obligation. The photographs and/or drawings in this document are for illustrative purposes only. Refer to the appropriate Operator's Manual for instructions on the proper use of this equipment. Failure to follow the appropriate Operator's Manual when using our equipment or to otherwise act irresponsibly may result in serious injury or death. The only warranty applicable to our equipment is the standard written warranty applicable to the particular product and sale and Terex makes no other warranty, express or implied. Products and services listed may be trademarks, service marks, or trade names of Terex Corporation and/or its subsidiaries in the USA and other countries. All rights are reserved. Terex is a registered trademark of Terex Corporation in the USA and many other countries.
© 2023 Terex Corporation.