

AGGREGATESCRUB™ P80

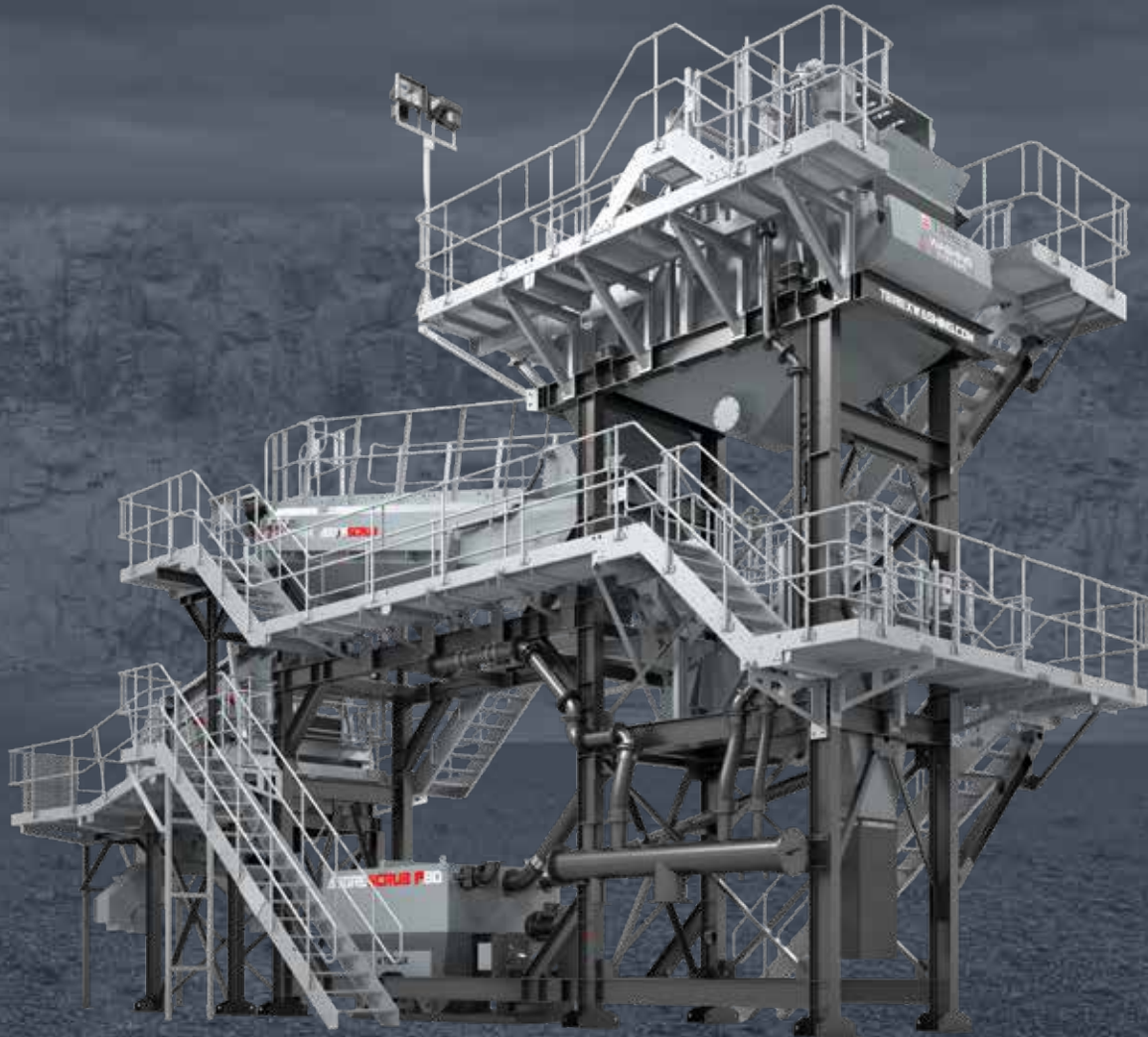

The Terex AggreScrub™ P80 PreScreen is the core of your wet processing plant. Particularly suited for C&D and excavation applications, combining rinsing, scrubbing & sizing and removal of light weight contaminants, all on a modular chassis.

AGGREGATES



RECYCLING



terex.com/washing

**DEDICATED TO WASHING,
DEDICATED TO YOU.**

The AggreScrub™ P80 combines modular design with enhanced wear protection and excellent maintenance access. It delivers high-efficiency scrubbing to remove clays, silts, organics and lightweight contaminants on a single integrated chassis, reducing operating costs and improving process reliability

Pre-Screening

3.6m x 1.5m (12' x 5') Single Deck Pre-Screen

- Designed to process up to 80mtph of feed material
- Provides efficient removal of undersize material before entering the logwasher
- The integrated wash box evenly distributes and fluidises the feed, enhancing screening efficiency and boosting overall plant performance

Contaminant Removal

1.8m x 0.6m (6' x 2') Trash Screen

- Dewateres and removes lightweight contaminants discharged from the logwasher
- Effectively handles organics, plastics and other floating debris

Process Slurry Management

Integrated Sump Tank and Pump

- The large-volume sump collects all slurry from the washing process, maintains a consistent operating level using an integrated float, and delivers stable conditions that optimise pump performance

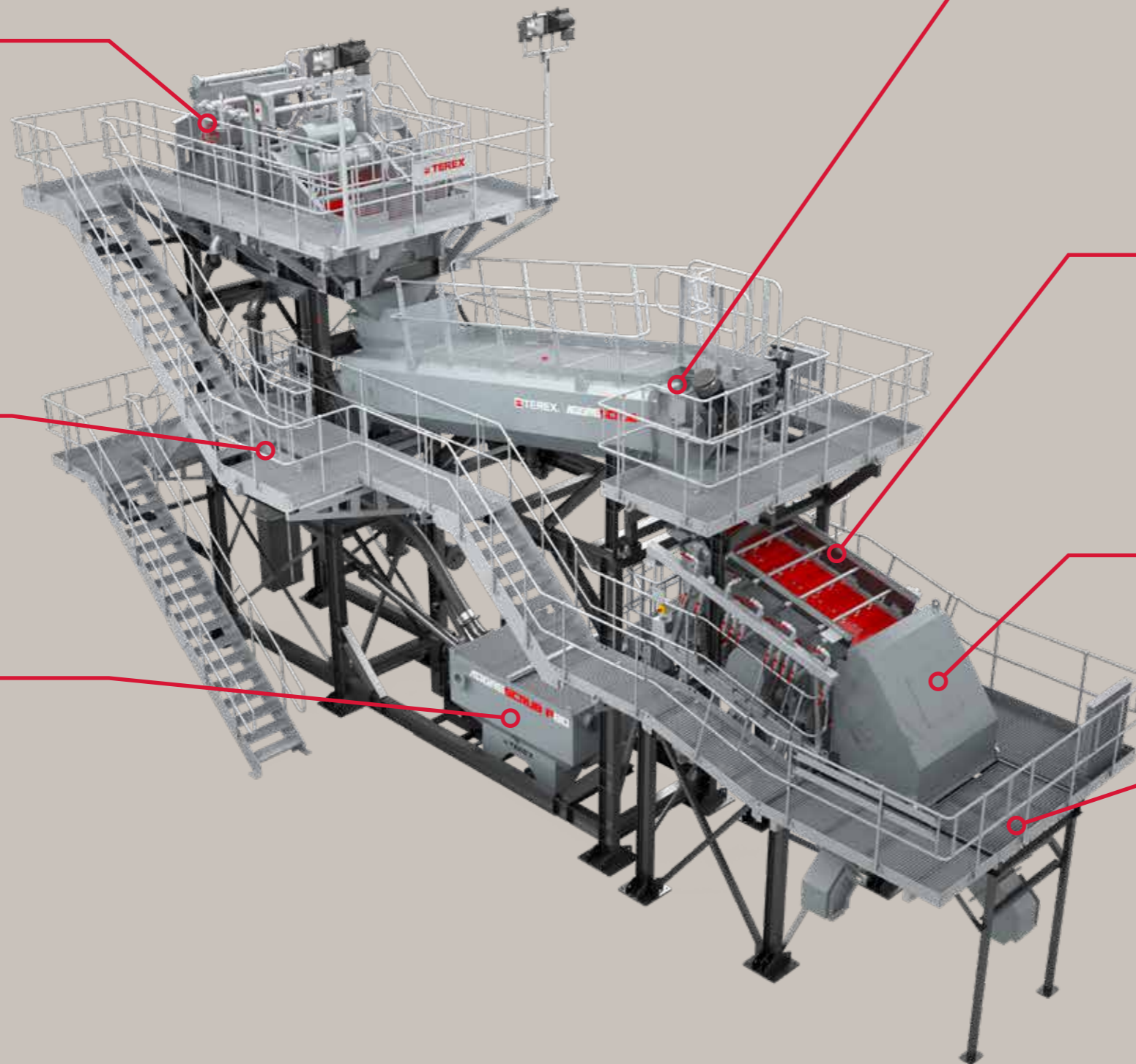

Scrubbing System

Twin Shaft PowerScrub™ 60 Logwasher

- Provides aggressive scrubbing action to remove adhered clays, silts and organics from the gravel fraction
- Adjustable operating angle for optimised retention time and improved scrubbing efficiency

Independent Dual High-Torque Drives

- Allow start-up under load, preventing blockages and reducing downtime*
- Improved system robustness when scrubbing variable or heavily contaminated material*
- Blades are arranged in a spiral formation, delivering continuous forward movement and aggressive material-on-material scrubbing ensuring a superior clean product

Post-Scrub Sizing

2.4 x 1.2m (8' x 4') Triple Deck Inclined Aggregate Screen

- Capable of producing up to three clean, sized aggregate products
- Provides efficient separation following the scrubbing process
- Fitted with integrated spraybars that provide an effective secondary rinse, improving product cleanliness and ensuring all remaining clays, silts and contaminants are washed away before final sizing

Screen Access

The roll-away product chute facilitates safe and efficient access to the scree decks for maintenance, and its adjustable configuration also enables on-chute product blending, allowing operators to combine selected aggregate fractions to meet specific customer requirements

Access & Maintenance

Fully Galvanised 800mm (32") Walkways with GRP Flooring

- Provide full maintenance access throughout the machine
- Galvanised structure ensures long-term corrosion resistance
- GRP flooring offers excellent slip resistance and minimal maintenance

AGGREGATES



RECYCLING



MATERIAL FLOW

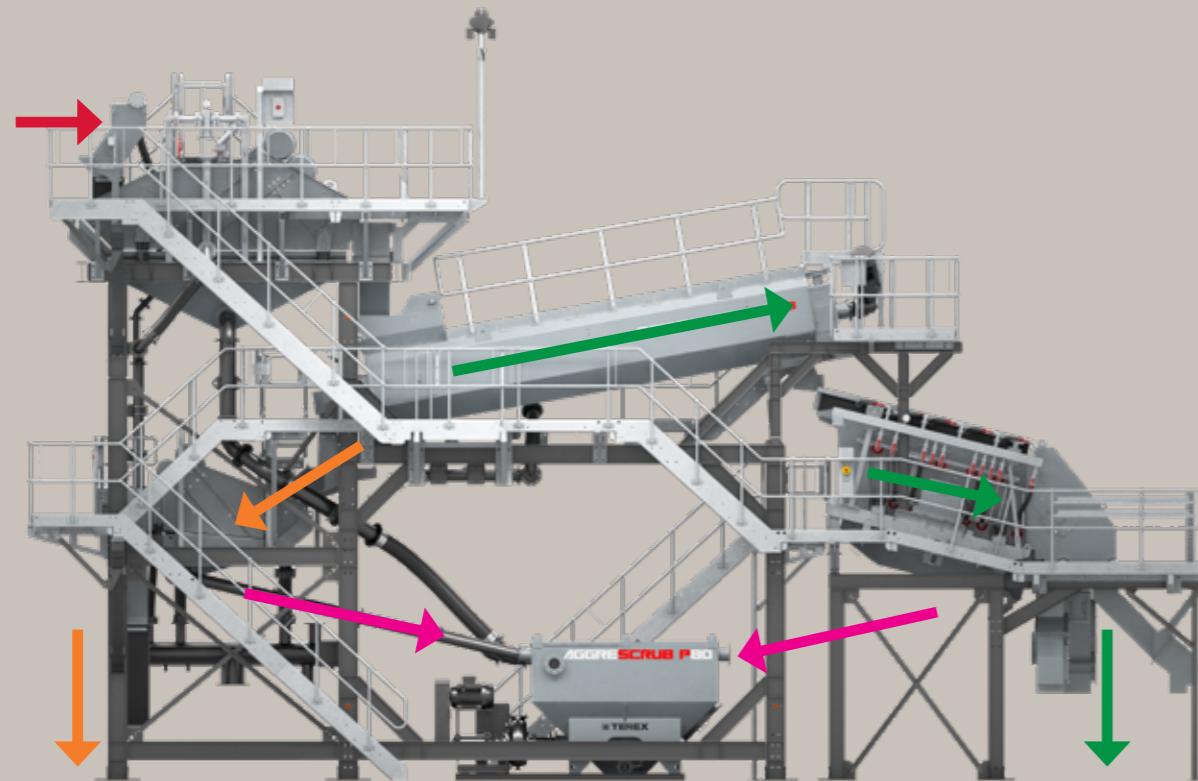

-  Feed material
-  Slurry (sand + water)
-  Trash / Organics
-  Scrubbed aggregate product

TECHNICAL SPECIFICATION

Machine Model	Aggregscrub P80
Max Tonnage (mtph [stph])	80 [88]
Pre-Screen (m [ft])	1.5 x 3.7 [5 x 12]
Post-Screen (m [ft])	2.1 x 2.4 [4 x 8]
Trash-Screen (m [ft])	0.6 x 1.8 [2 x 6]
Pump Size (mm [inch])	150/125 [6/5]
Total Power (kw [hp])	68.9 [92]

Machine Model	Aggregscrub P80
Max Height (mm [ft-"])	10349 [34']
Max length (mm [ft-"])	15750 [51' 9"]
Max Width (mm [ft-"])	5432 [17' 10"]
Chute Discharge Height (mm [ft-"])	1170 [3' 10"]

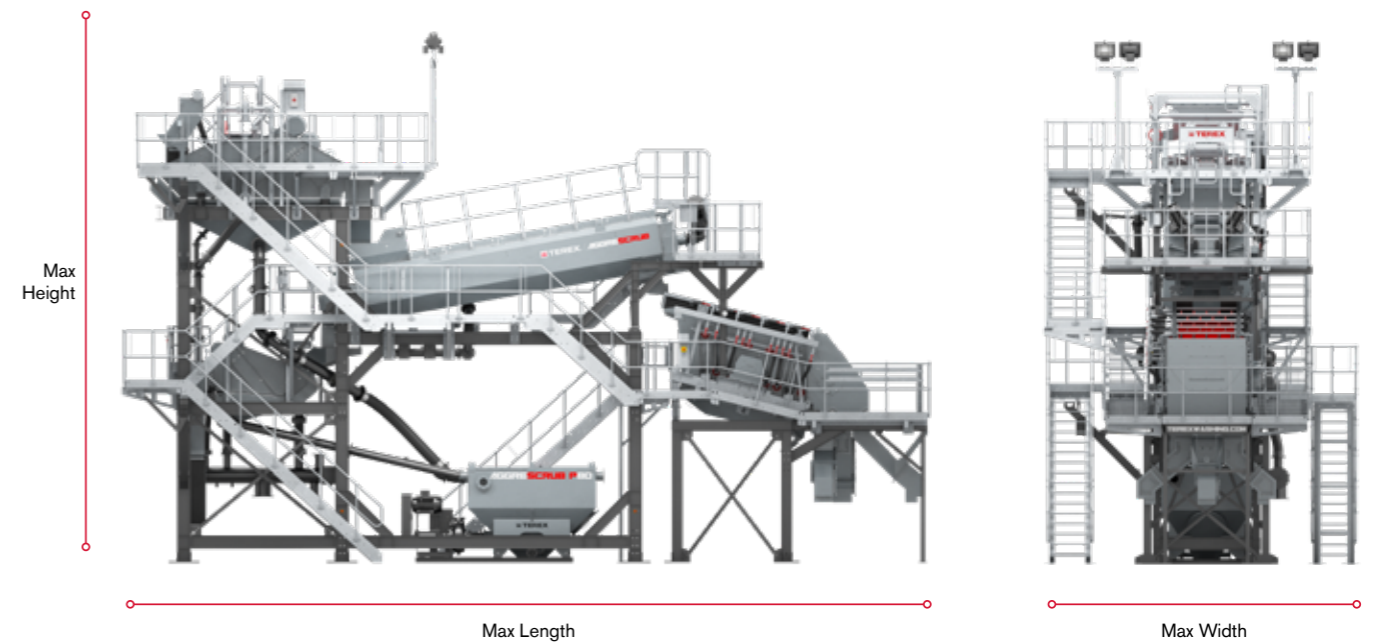

DIMENSIONS (TRANSPORT)

Machine Model	AggreScrub P80
Container	4x 40ft Trailers 2x Low Loaders

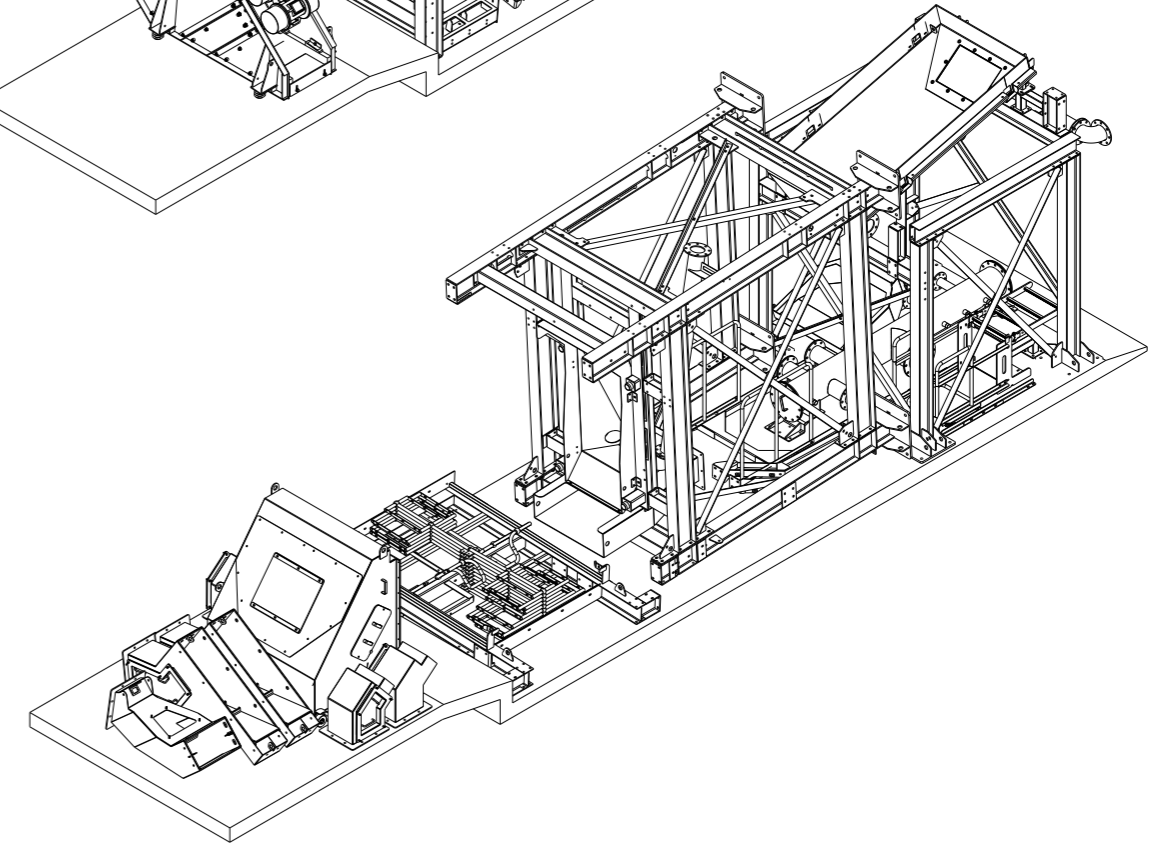
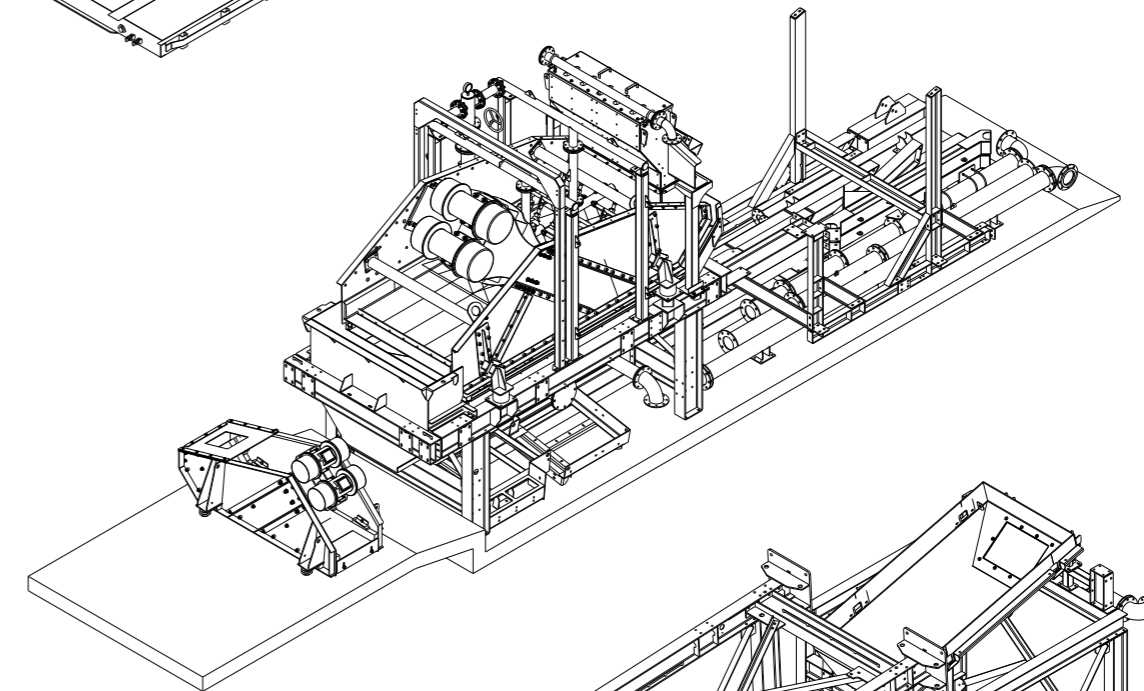
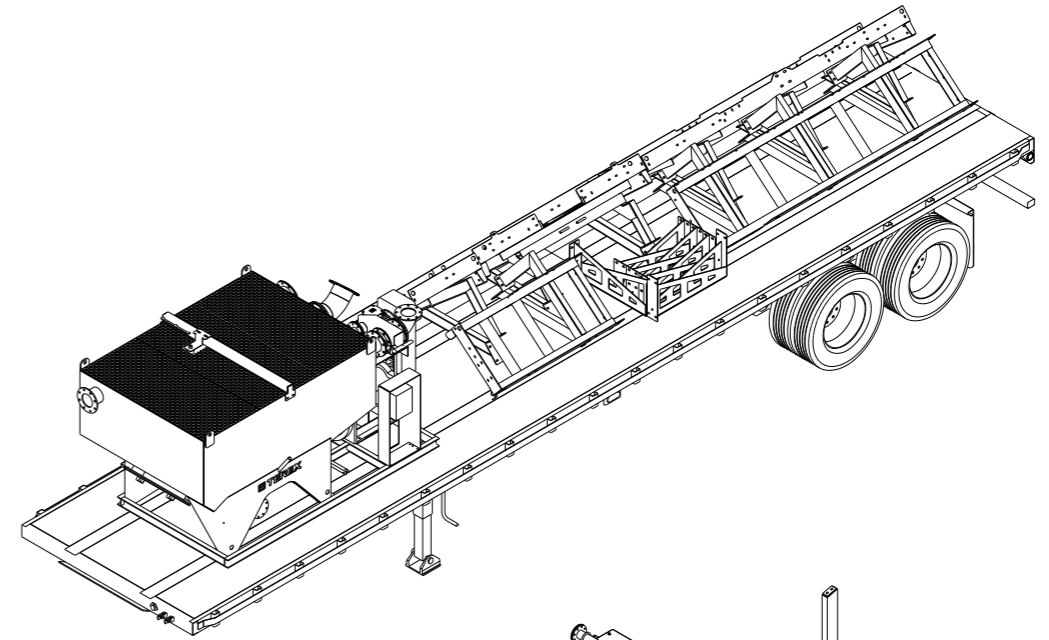
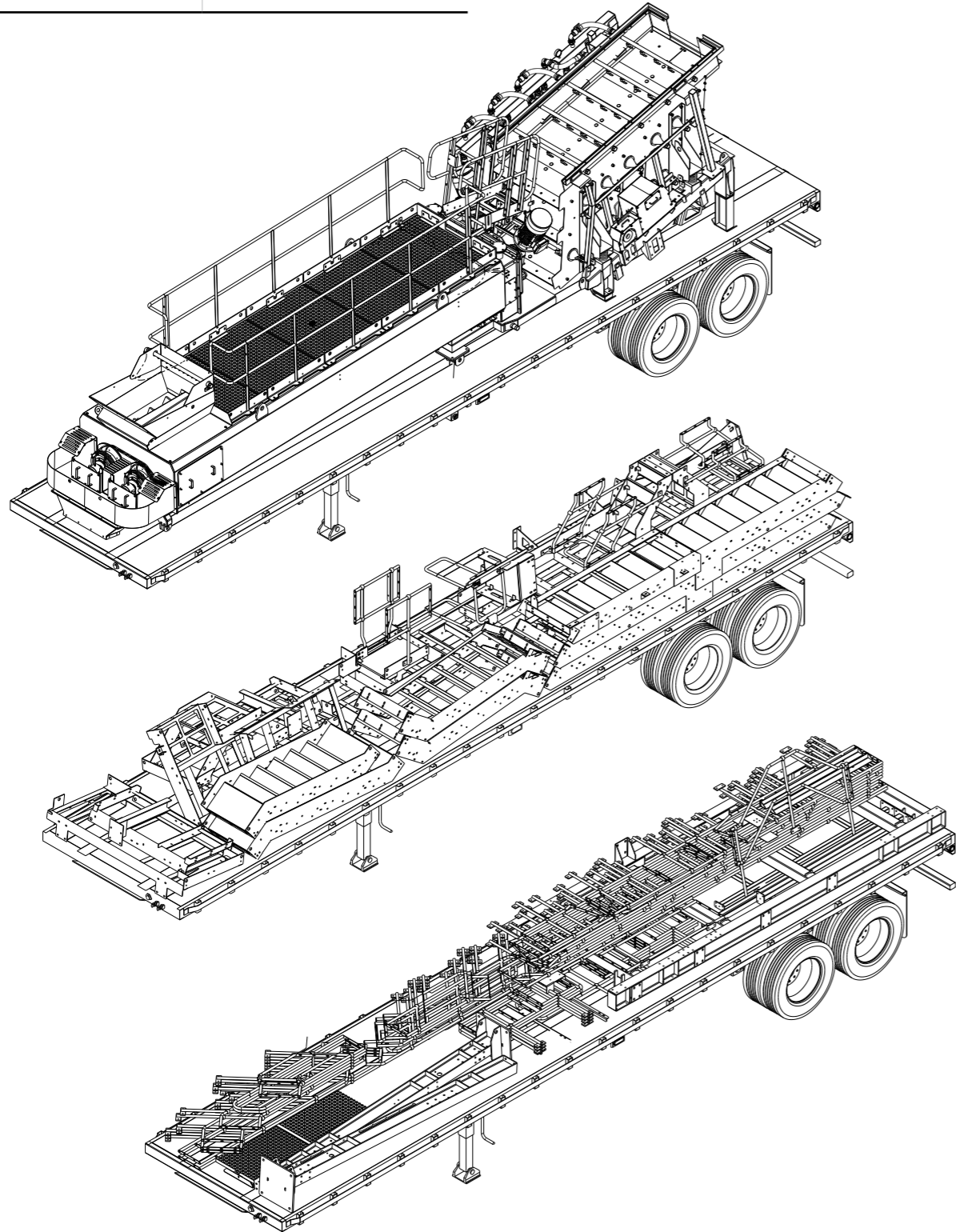



**DEDICATED TO WASHING,
DEDICATED TO YOU.**

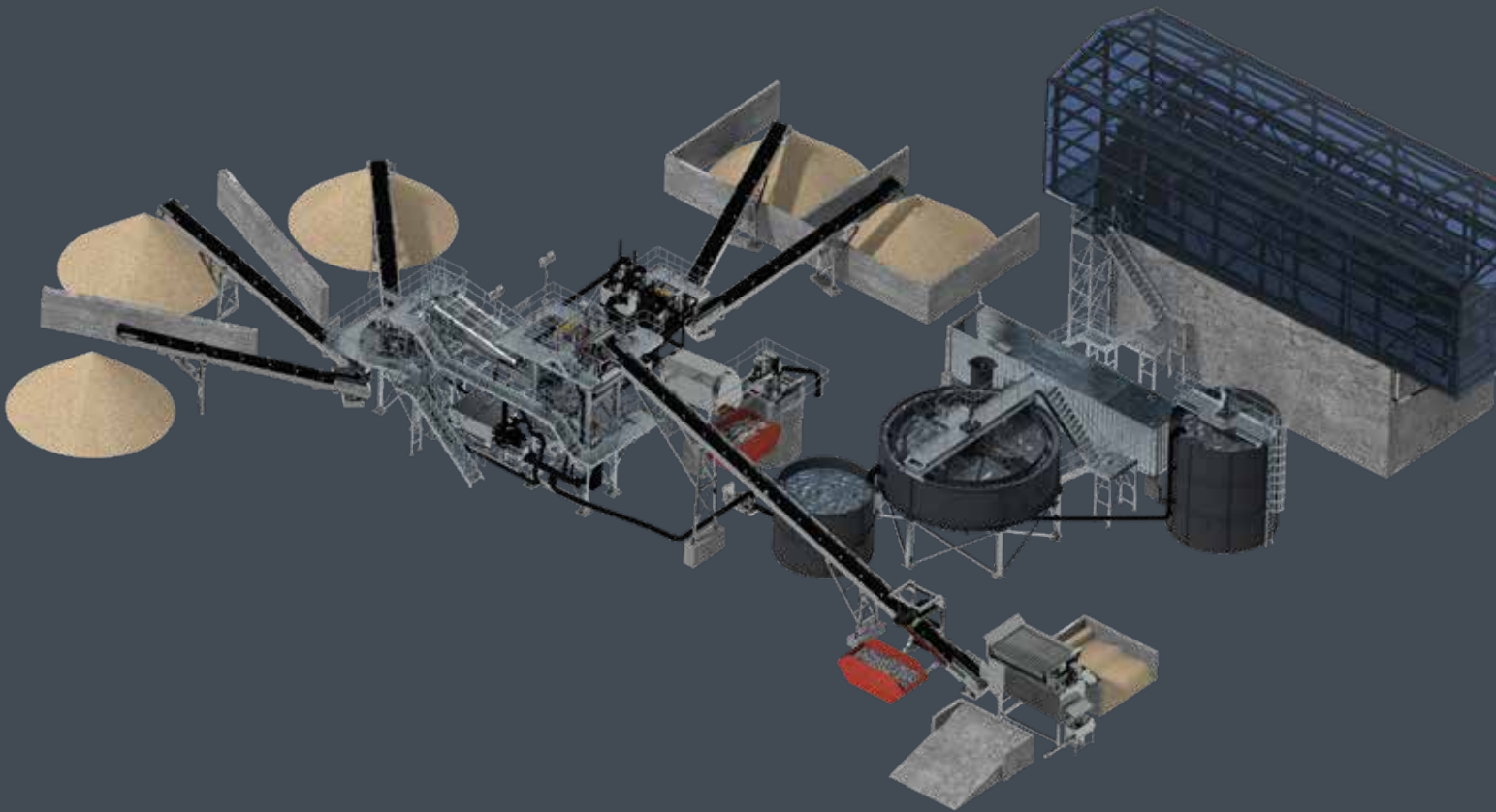

TEREX WASHING SYSTEMS

FARLOUGH SITE

32 Farlough Road,
Dungannon,
Co. Tyrone,
Northern Ireland, BT71 4DT

Tel: +44(0) 28 8771 8500
Email: TWS.sales@terex.com



www.terex.com/washing

Effective Date: April 2026 Product specifications and prices are subject to change without notice or obligation. The photographs and/or drawings in this document are for illustrative purposes only. Refer to the appropriate Operator's Manual for instructions on the proper use of this equipment. Failure to follow the appropriate Operator's Manual when using our equipment or to otherwise act irresponsibly may result in serious injury or death. The only warranty applicable to our equipment is the standard written warranty applicable to the particular product and sale and Terex makes no other warranty, express or implied. Products and services listed may be trademarks, service marks, or trade names of Terex Corporation and/or its subsidiaries in the USA and other countries. All rights are reserved. Terex is a registered trademark of Terex Corporation in the USA and many other countries.
© 2026 Terex Corporation.