



PRODUCT OVERVIEW

 AGGREGATES  RECYCLING  WATER MANAGEMENT

DEDICATED TO WASHING, DEDICATED TO YOU.



CONTENTS

Washing As It Should Be 5
 Washing Made Simple 6-7

APPLICATION SOLUTIONS

Aggregates 8-9
 Recycling 10-11
 Industrial Sands 12-13
 Mining 14-15
 Water Management 16-17
 4SITE 18
 Applications, Training & Support, Laboratory Testing 19

YOUR PRODUCT CHOICE

MODULAR SOLUTIONS

Aggresand™ 21-23

SCRUB

AggreScrub™ 28-29

SIZE

M Range 30
 Sreenbox Range 31

CLASSIFY

FM Compact 32
 FM Hydro 33
 FM UltraFines 34-35
 FM Direct Feed 36
 FM Conexus 37
 FM Bucket Wheel 38
 Bucket Wheel Sand Plants 39
 Mobile Sand Screw Plants 40
 Sand Screw Plants 41
 Frac Pro & Attrition Cells 42

FEED

H Range 43
 AggreScalp™ ??

STACK

AggreStac™ 44
 Modular Conveyors 45-46

WATER MANAGEMENT SOLUTIONS

Waterpumps 47
 Water Management Solutions 48-49

TEREX WASHING SYSTEMS SERVICES FOR YOU

Growing Global Network 50
 Distributor Network 51
 Automation & Control 52
 Finance 53



Specifications are subject to change without notice and should be confirmed with Terex Washing Systems before final purchase to ensure accuracy and suitability for your requirements.

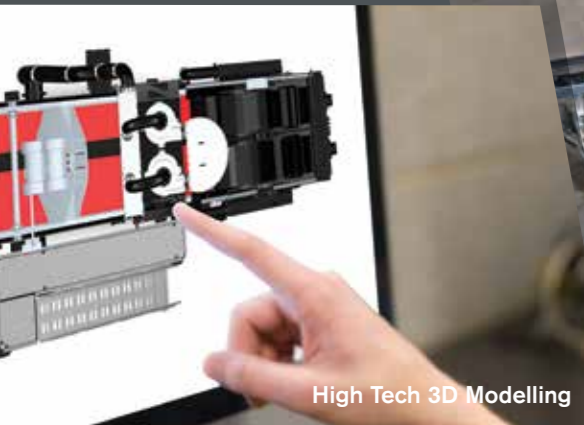

High Tech 3D Modelling



An unrivalled heritage of over 60 years development experience and expertise in the washing solutions industry, has resulted in today's world class leading equipment - turning virgin and waste materials and minerals into high value, saleable products.

Transforming Waste into Value with Terex® Washing Systems

At Terex® Washing Systems, we help businesses turn waste into profit. Our innovative washing solutions convert virgin and waste materials into high-value, saleable products—unlocking new revenue streams, reducing landfill waste, and contributing to a more sustainable, circular economy.

With over 60 years of expertise, we understand the challenges businesses face in meeting stringent material standards while maximizing efficiency and return on investment. That's why our cutting-edge solutions are designed to recover more usable material, reduce waste disposal costs, and improve operational sustainability.

Our global reach ensures rapid response times, expert local support, and readily available parts—minimizing downtime and keeping your operations running smoothly. From small independent quarries to multinational mining and construction companies, Terex Washing Systems is the trusted partner for businesses looking to increase profitability while reducing environmental impact.

By choosing Terex Washing Systems, you're not just investing in industry-leading washing equipment—you're investing in smarter, more sustainable ways to grow your business



Aggresand™ 206 Control Panel



MODULAR SOLUTIONS



Today's end users rightly expect total understanding of their requirements and total performance. Terex Washing Systems was founded on this principle and we have combined our ability to offer competitive single unit 'standardised' equipment with the capacity to design and deliver complete turnkey projects for even the most demanding materials and requirements.

CLASSIFY



Highly comprehensive range of dewatering options for fine materials including screw dewaterers, bucket wheels, and hydrocyclone technologies, all proven on a global basis. Unique ability to offer off-the-shelf ready-made products or to design complete bespoke solutions.

SCRUB



Static and modular systems offering aggressive attrition for sticky and high clay content materials. Highly effective with overburdens, clay-bound ores and recycled materials containing lightweight contaminants.

FEED & STACK



High performance, heavy duty electrical screening solutions, ideal for aggregate and recycling applications or you can opt for our stand alone feeder options.

Cost effective efficient modular and mobile units that can be used on a stand-alone basis or integrated with larger Terex Washing Systems systems. Hydraulic, electric, static, mobile. Move it, wash it, stack it, sell it.

SIZE



From our unique track mounted M-Series which can operate on a wet or dry basis through to our comprehensive range of static and modular units for sizing and dewatering Terex Washing Systems offers a substantial selection of screens covering numerous applications and sectors.

WATER MANAGEMENT



All washing systems need water but Terex Washing Systems designs and efficiencies keep requirements to a minimum. Proven water management and recycling systems, from thickeners to filter presses and moisture reclamation systems, ensure that operators in even the most controlled or arid environments can produce high quality materials at a low cost per ton.

AGGREGATES

Delivering High-Quality, In-Spec Aggregates with Efficiency and Innovation.

From the sands that shaped Dubai's skyline to the aggregates that built the London Olympic infrastructure, Terex® Washing Systems is the trusted partner for world-leading contractors and materials suppliers. Our washing solutions ensure consistent, high-quality, in-spec products—helping businesses meet strict industry standards while maximising efficiency and profitability.

With over 60 years of experience in aggregate washing, we understand the complexities of different raw materials, project requirements, and regional demands. Regardless of feed material or final product specifications, every operation shares the same goal: producing high-quality materials at the lowest cost per ton. Terex Washing Systems delivers with modular, high-performance systems designed for rapid installation, flexibility, and ease of use—ensuring your plant is ready to adapt as market needs evolve.

Backed by the industry's most extensive global dealer network, we provide localised support at every stage of your project.

Whether you're processing natural sand and gravel, recovering high-value aggregates from overburden, or maximising fines recovery, Terex Washing Systems solutions unlock new revenue streams, reduce waste, and drive long-term success. We're here to help you deliver on your promises—every time.

**Always innovating,
always one step ahead.**

High Frequency Dewatering Screen



DID YOU KNOW?

That aggregates used in the construction of the Britain - France Channel Tunnel was washed using a Terex Washplant.



Part Rinsing/Sizing Screen

RECYCLING

Driving the Circular Economy with Modular & Bespoke Wash Recycling Solutions.

As construction and population density increase, the need for sustainable material reuse has never been greater. The UK has become a benchmark for construction materials recycling, and Terex® Washing Systems has been at the forefront of this transformation—shifting the industry from basic crush-and-screen methods to fully integrated, value-driven recycling solutions.

Our advanced washing technology turns construction and demolition waste into high-value materials, reducing landfill dependency and supporting the circular economy. Whether through modular systems like AggreScrub—designed for rapid deployment and relocation—or fully customised solutions engineered to handle the most complex materials, we deliver flexibility, efficiency, and sustainability in every project.

Recycled materials present unique challenges: inconsistent feed material, the demand for high-spec products, water scarcity, and land use constraints. Terex® Washing Systems addresses these with a complete suite of crushing, screening, washing, and water management solutions that optimise recovery, minimise waste, and maximise profitability.

As global industries recognise the urgency of sustainable resource management, Terex® Washing Systems continues to innovate—offering adaptable, high-performance solutions that help operators generate more revenue from recycled materials while reducing environmental impact. From modular wash plants to bespoke designs for the most demanding applications, our solutions aren't just meeting the challenges of today—they're shaping the future of material recycling.



See our Recycling brochure for our complete solution offering

Our constantly evolving product and process solutions ensure maximum productivity and most importantly product quality.



DID YOU KNOW?

Recycled aggregates used in the construction of facilities used for the Commonwealth Games 2014 were washed using a Terex Washplant.



WATER MANAGEMENT

Maximize Water Efficiency, Minimize Waste

Every wash plant needs water—but with Terex Washing Systems, you need less. Our solutions reduce water loss, recycle process water, and maximize efficiency, cutting costs while ensuring sustainable operations.

We design our systems to eliminate unnecessary losses from spills and leaks, while internally recycling water wherever possible. Our ground sumps capture and reuse washdown and rainwater, further reducing reliance on fresh water.

For every project, our Applications & Engineering Review team creates a customized water flow plan, identifying opportunities to reduce waste and optimize water recovery. Our advanced dewatering systems ensure stockpiles are as dry as possible, delivering ready-to-sell material with minimal water content.

Terex Washing Systems offers a comprehensive range of water and sludge management solutions, tailored to your material type, volume, space, and budget. From Aqua Cone and rake thickeners to high-efficiency filter presses, our systems are designed to return maximum water to your plant while minimizing operational costs.

With Terex Washing Systems, you get a smarter, cost-effective approach to water management—reducing waste, improving efficiency, and driving sustainability in every wash operation.



Whichever material you wash
you will need water.

With Terex Washing Systems
you need less.



DID YOU KNOW?

Material used in the construction of the Brenner Base Tunnel (Austria) is being washed using an AggreSand™ 165.



APPLICATIONS

- Construction & Demolition Waste Material
- Virgin Aggregate
- Manufactured Sand
- Sand & Gravel
- Crushed Rock
- Crusher Dust
- Scalpings
- Iron Ore
- Other Mineral Ores



TRAINING & SUPPORT

Terex Washing Systems offers fully tailored training packages for both dealers and customers alike. This training covers all aspects of our machinery, including basic operational data, correct sizing of screens, pumps, cyclones and full sales and application training.

For further information on training or to book a training session email: TWS.Applications@terex.com



LABORATORY TESTING

Terex Washing Systems offers full in-house sample analysis and testing of proposed products. This process allows us to specify the correct screening media apertures so that the customer achieves the desired product size. Sieve analysis is extensively used as a powerful quality control and acceptance tool. The gradation data is used to calculate relationships between various aggregates or aggregate blends, to predict trends during production and to check compliance with such blends.



We also test for many other factors including correct specification of flocculent type, oil / water separation etc.

For further information on your requirements and to discuss your specific application: Email: TWS.Applications@terex.com

AggreSand™ 165 / 206

AggreSand™ is a highly versatile integrated washing station with outstanding performance capability across a wide range of materials and the ability to offer up to 5 washed and sized products. Its readily portable format makes it particularly suitable for green-field applications / contractor use / temporary planning permission sites but operators more used to static installations will still appreciate the small footprint and minimal site preparations required. In all cases installation time is significantly less than conventional builds thanks to the high level of factory pre-fitting and connections. The no-compromise design ethos adapted ensures maximum serviceability and performance despite the highly integrated and compact nature of the system with numerous innovative features including easily removed pumps, ready access to screening media and intuitive controls. The range includes numerous modular configurations but all are based around the choice of a 16x5' or 20x6' washing screen and a choice of sand output capacities.

FEATURES AND BENEFITS

Fast Setup, Quick ROI

Modular plug-and-play design gets you producing faster.

Easy Installation

Pre-wired & pre-plumbed for hassle-free setup.

Smart Automation

Touchscreen control for real-time monitoring & optimization.

Custom Fit

Adjustable grid & screen media for any material.

Minimal Downtime

Low-level access for quick maintenance & cleaning.

Easy to Move

Compact, transportable design for flexible relocation.

APPLICATIONS

-  AGGREGATES
-  RECYCLING

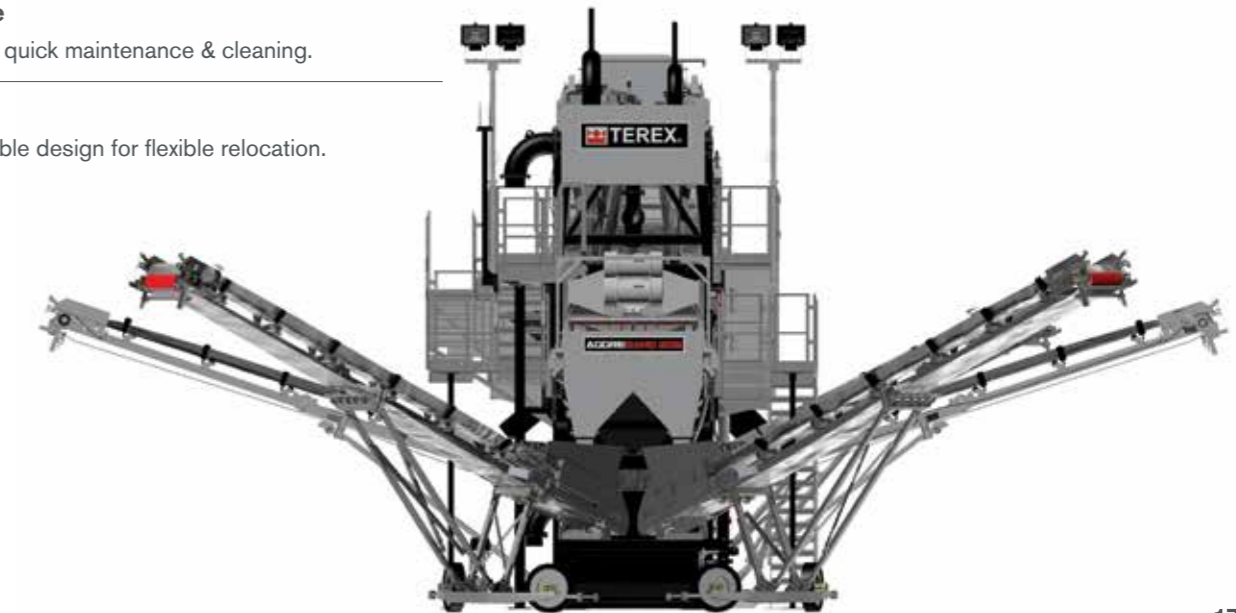

AggreSand™ 206, UK



DID YOU KNOW?

Our washplant at Coastal Quarry in Australia is supplying sand for Snowy 2.0 — a major pumped-hydro expansion of the iconic Snowy Mountains Hydro-electric Scheme in Australia.

AggreSand™ 165 / 206

KEY FEATURES & BENEFITS

- Automated radial sand stockpilers
- 350m³ (458yds³) stockpile per conveyor
- 800m³ (1046yds³) single sand

- Choice of 3.m x1.5m (12'x5') DW screen (producing up to 120tph) or 4.8m x 1.8m (14' x 6') DW screen (producing up to 200tph)
- High frequency dewatering screen delivering superior moisture reduction

- Single or twin cyclones with drop in replaceable liners

- Choice of 4.9m x 1.5m (16'x5') or 6m x 1.8m (20'x 6') washing screen
- Isolated spraybars
- Polyurethane decks
- Sealed catchment tank rubber lined
- Aggregate blending chute
- Service accessible rolling chute

- Optional overband magnet for the removal of ferrous metals when operating in recycling applications

- Modular 12m³ (16yds³) capacity hopper
- Radio controlled tipping grid or vibrating grid
- Variable speed belt feeder
- 37Kw (50hp) electric hydraulic powerpack

- Advanced automated control system with remote communication and radio

- All pumps have replaceable rubber liners for extended wear life
- Roll-out pump feature for easy maintenance

- 1050mm (41") wide belt
- Integrated sealed washbox
- Raisable head section for screen access



AggreScalp™ 165

The Terex® AggreScalp™ is a versatile, high performance heavy duty electric screening machine that has the flexibility to operate as a 2-way or 3-way split screener. The highly aggressive screen can accept media including bofor bars, finger screens, woven mesh and 3D punch plates, which allows it to be used across a wide variety of applications.

The AggreScalp™ can work in conjunction with the Terex® AggreSand™ range by providing a consistent feed material even in difficult applications. Together they form an efficient, lower operating cost aggregate and recycling solution.

FEATURES AND BENEFITS

Easy to Move

Semi-mobile design for quick relocation.

Lower Costs

Energy-efficient 40kW electric power cuts fuel expenses.

Fast Setup

Integrated hydraulics enable rapid installation.

Plug & Play

Pre-wired & pre-plumbed for hassle-free start-up.

Seamless Flow

Integrated conveyors improve efficiency.

Flexible Output

2-way & 3-way split for precise separation.

APPLICATIONS

AGGREGATES **RECYCLING**

KEY FEATURES AND BENEFITS

HOPPER & FEED CONVEYOR

- 7m³ capacity (9.2 cu yd) Hopper
- Manufactured from wear resistant steel with optimised reinforcement
- Heavy duty sides with manual folding back door for rear loading
- Heavy duty belt feeder with variable speed control
- 1300mm (51") Belt or Apron feeder options
- Manual folding Wing Plate option
- Optional Gate System to regulate material flow onto screen

CHASSIS

- Fully galvanized modular chassis designed for rapid set-up
- Modular I-Section & Plate Design
- Configurable for 2 or 3 way split mode of operation

COLLECTION CONVEYOR

- 1200mm (42") wide fines collection conveyor

Available wired to isolators or with an optional control panel.
Available in 2 or 3 way split configuration with optional tail conveyor for oversize material

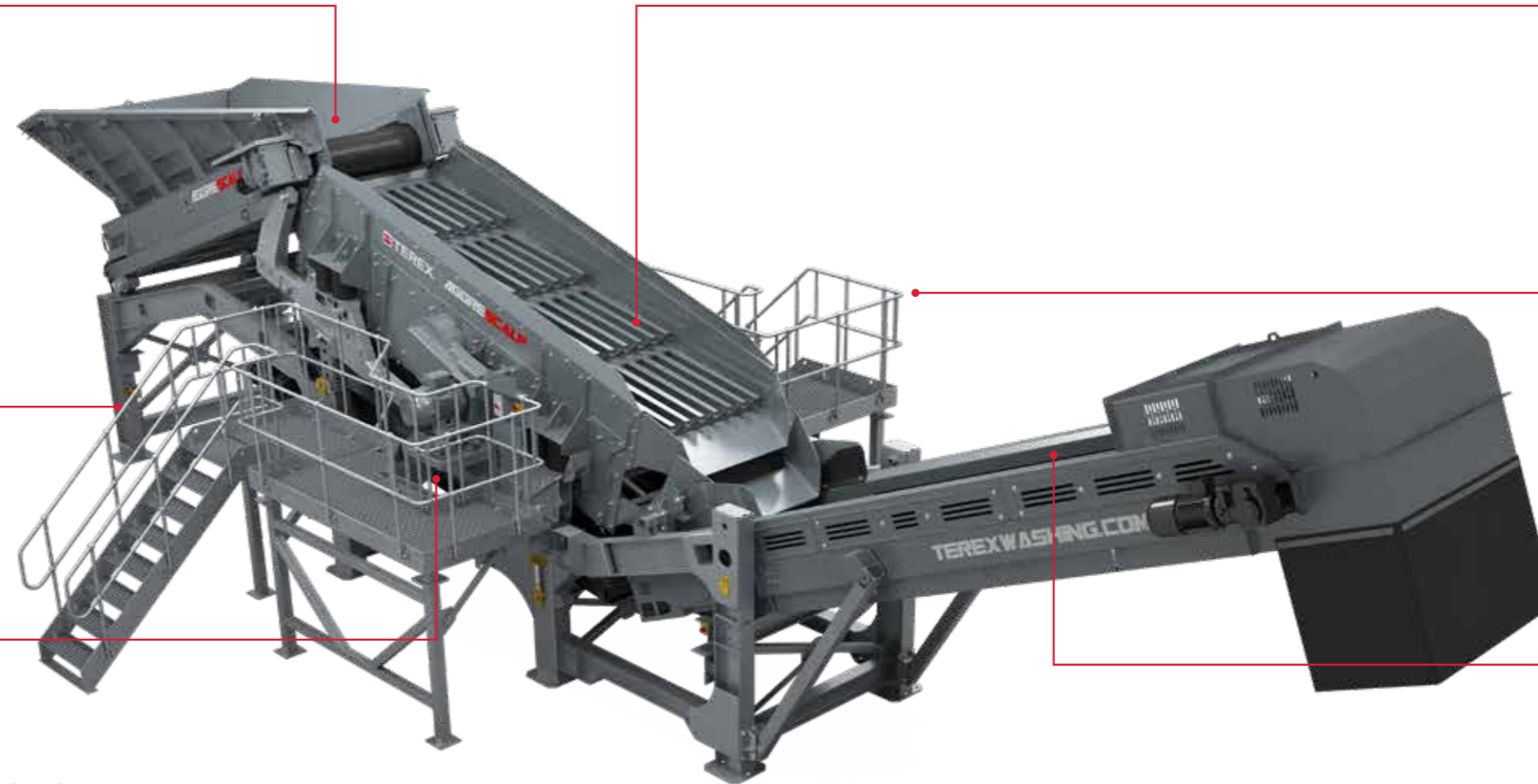

HEAVY DUTY SCALPING SCREEN

- 4.8m x 1.5m (16'x5') top & bottom decks
- 2deck, 2 bearing single shaft screenbox
- Modular screen suitable for bofor, finger, punch plate and mesh screen media & combined finger/ punch plate media

Options:

- Manual or optional hydraulic screen angle adjustment
- Screen blanket for material retardation
- Chain folding hanger for material retardation at discharge
- Quick release wedge screen tensioning system
 - (side tensioned only)
- Hydraulic Powerpack c/w directional control valve –
 - Screen Angle Adjustment
 - Screen Discharge Raise/Lower for media fitment

ACCESS

- Fully galvanized 800mm [32"] wide walkways with G.R.P flooring allowing comprehensive access
- Extended stair option available

TAIL / OVERSIZE CONVEYOR

- 1400mm (55") 3 ply chevron belt
- To suit 2 & 3-Way Split options
- Heavy duty impact rails



MODULAR SOLUTIONS



PowerScrub™ PS60 / PS200

The PowerScrub™ has earned the reputation of being one of the most high performance, robust logwashers available on the market.

The PowerScrub™ range uses two independently driven, counter rotating shafts that allow the logwasher to start-up under load preventing blockages. A combination of high wear resistant blades and paddles in a spiral formation, transition the material through the hull scrubbing the gravel fraction. Simultaneously, water added via spraybars facilitates the removal of organics, clays, and adhered contaminants, which float out through the rear.

Equally as comfortable in both sand & gravel and recycling applications, the PowerScrub™ machines can be combined with a range of finishing, sizing and trash screens to form a complete aggregate scrubbing and sizing station.

APPLICATIONS

-  AGGREGATES
-  RECYCLING

FEATURES AND BENEFITS

Faster, Cleaner Output

Designed for higher efficiency, delivering cleaner material quickly.

Versatile & Adaptable

Built for recycling, easily modified for gravel applications.

Intensive Material Cleaning

Dual spiral axles & exchangeable blades ensure thorough mixing.

Water-Efficient

Recirculates water for sustainable operation.



AggreScrub™ P80

THE CORE OF YOUR WET PROCESSING PLANT

The AggreScrub™ P80 combines modular design with enhanced wear protection and excellent maintenance access. It delivers high-efficiency scrubbing to remove clays, silts, organics and lightweight contaminants on a single integrated chassis, reducing operating costs and improving process reliability

APPLICATIONS



AGGREGATES



RECYCLING

FEATURES AND BENEFITS

Multi-Product Efficiency

Produces up to 3 grades of washed, screened aggregate.

Fast Setup

Modular design for quick installation.

Hassle-Free Operation

Pre-wired & pre-plumbed for seamless startup.

Smart Automation

Touchscreen control for real-time monitoring.

Optimized Cleaning

Adjustable logwasher angle for better material retention and trash removal.

Durable

Rubber Lined Centrifugal Pump.
Galvanised structure.
Fully lined wear parts.

Easy Transport

Compact design for containerised transport.

Maintenance

Comprehensive access to all serviceable areas for maintenance.

Pre-screening

- 3.6m x 1.5m (12' x 5') Single Deck Pre-Screen
- Designed to process up to 80mtph of feed material
- Provides efficient removal of undersize material before entering the logwasher
- The integrated wash box evenly distributes and fluidises the feed, enhancing screening efficiency and boosting overall plant performance

Contaminant Removal

- 1.8m x 0.6m (6' x 2') Trash Screen
- Dewateres and removes lightweight contaminants discharged from the logwasher
- Effectively handles organics, plastics and other floating debris

Process Slurry Management

- Integrated Sump Tank and Pump
- The large-volume sump collects all slurry from the washing process, maintains a consistent operating level using an integrated float, and delivers stable conditions that optimise pump performance

Access & Maintenance

- Fully Galvanised 800mm (32") Walkways with GRP Flooring
- Provide full maintenance access throughout the machine
- Galvanised structure ensures long-term corrosion resistance
- GRP flooring offers excellent slip resistance and minimal maintenance

Screen Access

The roll-away product chute facilitates safe and efficient access to the screen decks for maintenance, and its adjustable configuration also enables on-chute product blending, allowing operators to combine selected aggregate fractions to meet specific customer requirements



Scrubbing System

- Twin Shaft PowerScrub™ 60 Logwasher
- Provides aggressive scrubbing action to remove adhered clays, silts and organics from the gravel fraction
- Adjustable operating angle for optimised retention time and improved scrubbing efficiency

Independent Dual High-Torque Drives

- Allow start-up under load, preventing blockages and reducing downtime
- Improved system robustness when scrubbing variable or heavily contaminated material
- Blades are arranged in a spiral formation, delivering continuous forward movement and aggressive material-on-material scrubbing ensuring a superior clean product

Post-Scrub Sizing

- 2.4 x 1.2m (8' x 4' Triple Deck Inclined Aggregate Screen
- Capable of producing up to three clean, sized aggregate products
- Provides efficient separation following the scrubbing process
- Fitted with integrated spraybars that provide an effective secondary rinse, improving product cleanliness and ensuring all remaining clays, silts and contaminants are washed away before final sizing

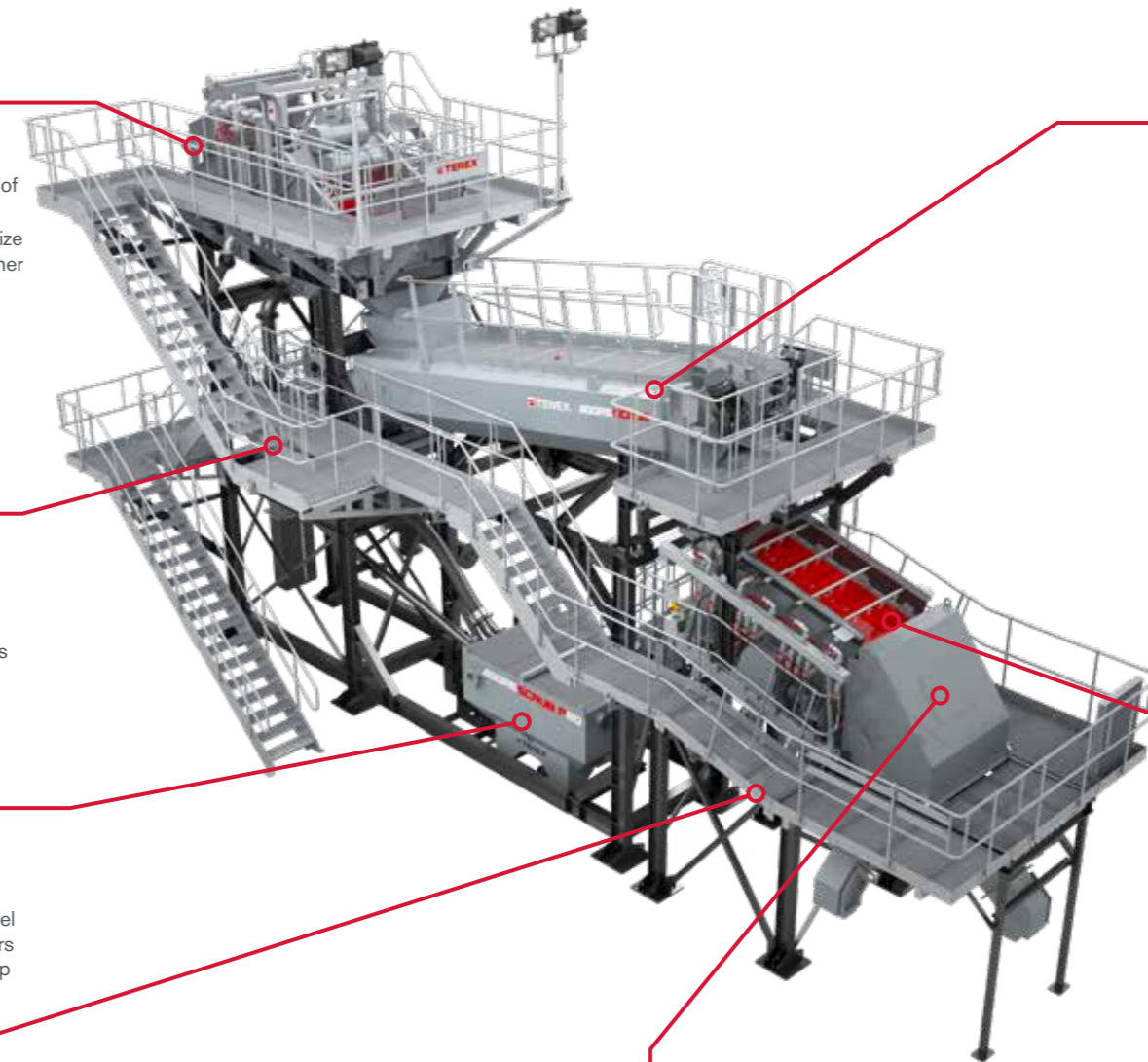

AggreScrub™ 150

SCRUB, SIZE, SEPARATE

The AggreScrub™ 150 carries through all the same features of the PowerScrub™ range while adding the benefit of modularity & market leading easy maintenance features. Key benefits for customers include the improved wear characteristics, reduced costs, and the ability to effectively scrub aggregates and float out clays/silts/lights (wood/plastics) on one chassis. In addition, there are also a number of paddle options available depending on customers' needs, including the traditional hard wearing AR blades in 15 and 30mm variants as well as a high manganese steel option.

APPLICATIONS

- AGGREGATES**
- RECYCLING**

FEATURES AND BENEFITS

Multi-Product Efficiency

Produces up to 4 grades of washed, screened aggregate.

Fast Setup

Modular plug-and-play design for quick installation.

Hassle-Free Operation

Pre-wired & pre-plumbed for seamless startup.

Smart Automation

Touchscreen control for real-time monitoring.

Optimized Cleaning

Adjustable logwasher angle for better material retention and trash removal.

Durable & Customizable

Choice of high-tensile or manganese blades to suit your needs.

Easy Transport

Compact design fits in 2 containers for efficient relocation.

-
- Choice of AR 500 Blades OR Long-Life Cast paddles provide high levels of attrition
 - Deadbox style chute ensures feed point impact protection for the AggreScrub shafts
 - 1.8m x 0.6m (6' x 2') trash screen for dewatering of lightweight contaminants from logwasher
 - Unprecedented complete access around plant with galvanised walkways, access stairs and handrails
 - Twin Shaft Logwasher with angle adjustment, to scrub gravel fraction and float out organics & adhered contaminants
 - 2 Independent high torque drives allow the logwasher to start-up under load, preventing blockages
 - Single water inlet point
 - Advanced fully automated control system with remote communication
 - Integral sump tank and pump for collection and removal of dirty water
 - Wash down hose reel
 - Choice of 2.4m x 1.2m (8' x 4') Single Deck or 3.7m x 1.5m (12' x 5') 2 Deck aggregate screen capable of producing up to 4 sized products
 - Compact rolling chute assembly for easy access to screen media (Patent Pending)

Optional:
16x5 post-screen

M RANGE M1700X / M2100

With the M-Range™ Terex Washing Systems boasts the widest range of track or wheel mounted, fully mobile washing screens available.

Designed to work independently or with the other Terex Washing Systems range of equipment as part of an entire plant, the M-Range is ideal for short to medium term projects.

The Track mounted M1700X & M2100 offer the same features on a larger capacity unit, with the added benefits of being available in both 2 and 3-deck.

M-Range machines are available with various engine or dual power electric options.

Capable of producing up to 5 products, they also offer adaption kits to convert to a dry screening application within hours, resulting in the M-series being the most flexible units on the market.

2 & 3 Deck Options Available

APPLICATIONS

-  AGGREGATES
-  RECYCLING

FEATURES AND BENEFITS

Mobile & Self-Contained

Track-mounted with integrated feed hopper & conveyors for full mobility.

Rapid Setup

Ready to run in under 15 minutes, minimizing downtime.

Flexible Power Options

Tier 3, Tier 4F, Stage V & dual power for any site requirement.

Optimized Screening

Hydraulic screen angle adjustment for peak performance.

Custom Fit

Choice of grid & screen media to match your material.

Efficient Sand Recovery

Rubber-lined catchbox for single or dual-grade sand.

Maximum Versatility

Fines conveyor option enables dry screening when needed.



Screenbox Range 8x4 / 12x5 / 16x5 / 20x6 / 20x8

The Terex® Screenbox Range is designed for maximum production efficiency in applications including sand and gravel, coal, crushed stone, slag, recycled materials, concrete, iron ore and silica glass.

Available in sizes ranging from 2.4m x 1.2m (8' x 4') up to 6m x 1.8m (20' x 6') all Screenboxes come with the choice of 2 or 3 Decks and a range of media options.

Robust, easy to assemble structures to mount the screen unit are available in a variety of heights to integrate with other Terex Washing Systems equipment. Each structure includes integrated lined discharge chutes, walkways and access steps which can be assembled in a number of configurations to suit your site layout.

APPLICATIONS

-  AGGREGATES
-  RECYCLING

FEATURES AND BENEFITS

Maximize Output

Produces up to 4 washed aggregates and 1-2 sand grades in one system.

Low Maintenance, High Efficiency

Direct electric drive reduces upkeep and boosts performance.

Custom Screening Options

Choose wire mesh or polyurethane decks for optimal results.

Precise Water Control

Isolated spray bars with flow valves for maximum efficiency.

Safe & Accessible

Galvanized walkways & handrails provide easy maintenance access.

Quick Media Changes

Roll-away chute design allows fast, hassle-free adjustments.

Built for Durability

Rubber-lined chutes & washbox extend wear life and reduce downtime.



FINESMASTER

FM Compact

FM 60C / FM 120C / FM 120 2G / FM 200C / FM 200 2G / FM 300C

The Terex® FM Compact™ range are static sand recovery units designed to be both cost and energy efficient. The range uses centrifugal force within the cyclone(s) to remove clay, silt and slime from sand to bring it into specification. The range combines a collection tank, centrifugal slurry pump(s), hydrocyclone(s) and a dewatering screen on a single chassis.

APPLICATIONS

AGGREGATES

RECYCLING

FEATURES AND BENEFITS

Flexible Feed Options

Recover sand from wet feed or use dry feed with a bolt-on boiler box.

Maximize Material Recovery

Removes silt, slimes, and clays for cleaner, saleable sand.

Durable & Accessible

Galvanized steel structure with walkways for easy maintenance.

Low Maintenance

Self-regulating cyclone tank simplifies operation.

Extended Wear Life

Replaceable rubber liners in pumps and cyclones reduce downtime.

Drier Final Product

Dewatering screen reduces water content to 10–15%.

Plug & Play Integration

Pre-wired for seamless connection to other equipment.



FM Hydro

60 / 120 / 200

The FM Hydro™ is the complete sand classification plant combining sand washing and sizing on a single compact structure. The dewatering cyclone in combination with the flat bottom classifier enables the plant to produce in-spec sands from a single feed in point.

FEATURES AND BENEFITS

Precise Separation

Hydraulic classification removes light particles while retaining valuable material.

Custom Sand Production

Bed level control allows up to two specialty sands from one feed.

Optimized Water Flow

Multiple injection nozzles ensure even distribution at low flow rates.

Drier, Stockpile-Ready Output

High-frequency dewatering screen delivers instantly conveyable material.

Quick Spec Changes

Store up to 5 settings for fast, automated product adjustments.

Low Maintenance, Long Life

Fully lined classifier with no moving parts exposed to slurry reduces wear.

APPLICATIONS

AGGREGATES

RECYCLING

- Rubber lined 500mm hydrocyclone
- Flat-bottomed upward current classification unit
- Rubber lined pump
- Comprehensive walkway provides access for maintenance
- Completely galvanised walkway
- Electric machine with complete on board PLC control panel
- Single electrical power source required
- Single water inlet source



- Rubber lined dewatering hydrocyclone
- High frequency, linear motion dewatering screen
- Full-width modular polyurethane dewatering media for quick change out
- Polyurethane side modules for superior screen protection.
- Low friction, lined discharge 2 grade chute with angle adjustment and blending capabilities
- Self regulating float level ensures consistent tank volume and pump run-dry protection .
- Tank drainage valves for plant maintenance

FINESMASTER

FM UltraFines™

The Terex® FM UltraFines™ is a crucial step in efficient management and recovery of ultrafines sand from waste water streams, produced from washing processes.

This ultra-fines recovery unit can recover material as low as 40 micron, thus reducing the volume of solids reporting to storage ponds or water treatment plants.

Bringing together a centrifugal pump, a cluster of hydrocyclones and a high frequency dewatering screen on one chassis. The FM UltraFines™ also boasts a uniquely designed conical tank and anti-turbulence system, which is essential in the process of ultra-fines recovery.

APPLICATIONS

 AGGREGATES

 RECYCLING

FEATURES AND BENEFITS

High-Capacity Processing

Large conical tank handles more material efficiently.

Quick Maintenance

Bolt-on sides & removable panels for easy service access.

Durable & Accessible

Lined pump & motor for longer life and simple servicing.

Easy Cleanout

Cyclone catch boxes ensure hassle-free maintenance.

Drier Output

High frequency dewatering screen delivers instantly stockpile-ready material.

Built to Last

Galvanized, reversible walkways designed for extended service life.

Optimized Performance

Three pump options tailored to your application.

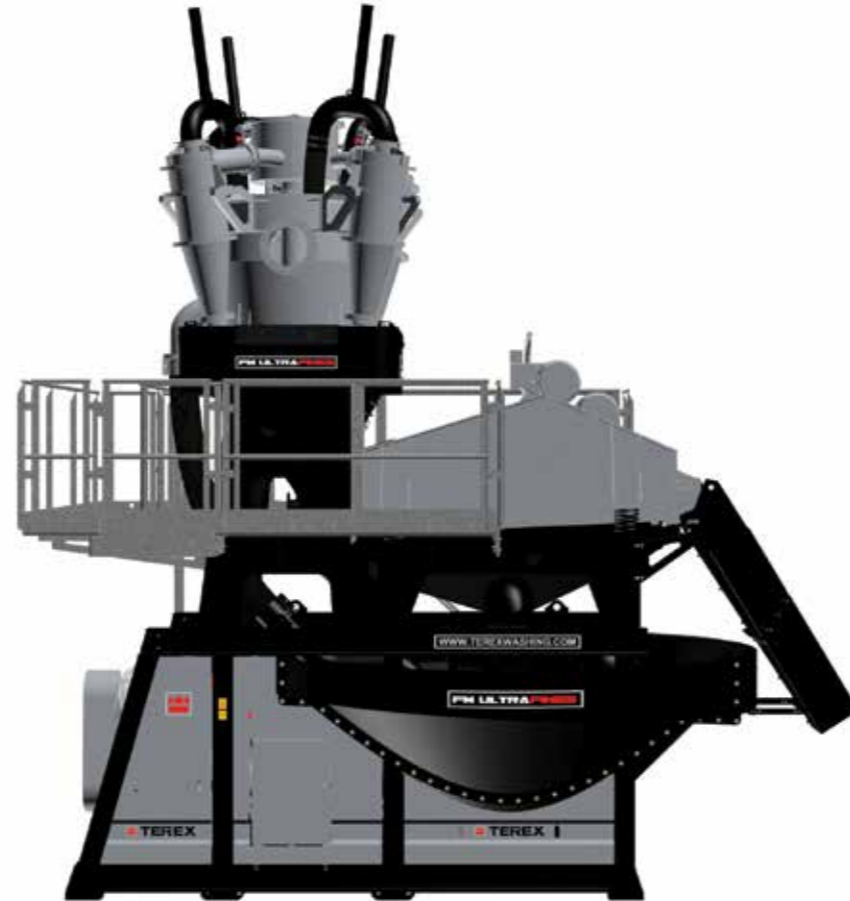

- Hydrocyclones with drop-in replaceable liners
- Single 12" overflow discharge connection

- Fully galvanised access walkways for maintenance of dewatering screen & cyclone spigots.
- Intelligent symmetrical design allows assembly to suit left or right access.

- Single 10" rubber lined feed point can be configured left or right to suit site set up.
- Anti-turbulence feed box provides controlled wearing & reduced settling time.
- Conical tank design eliminates risk of fines build up.
- Bolt-on sides allow simple containerisation and site set-up.
- Rubber lined pump with electric motor
- Replaceable rubber liners for extended wear-life.



- Lift out pump feature for easy maintenance.

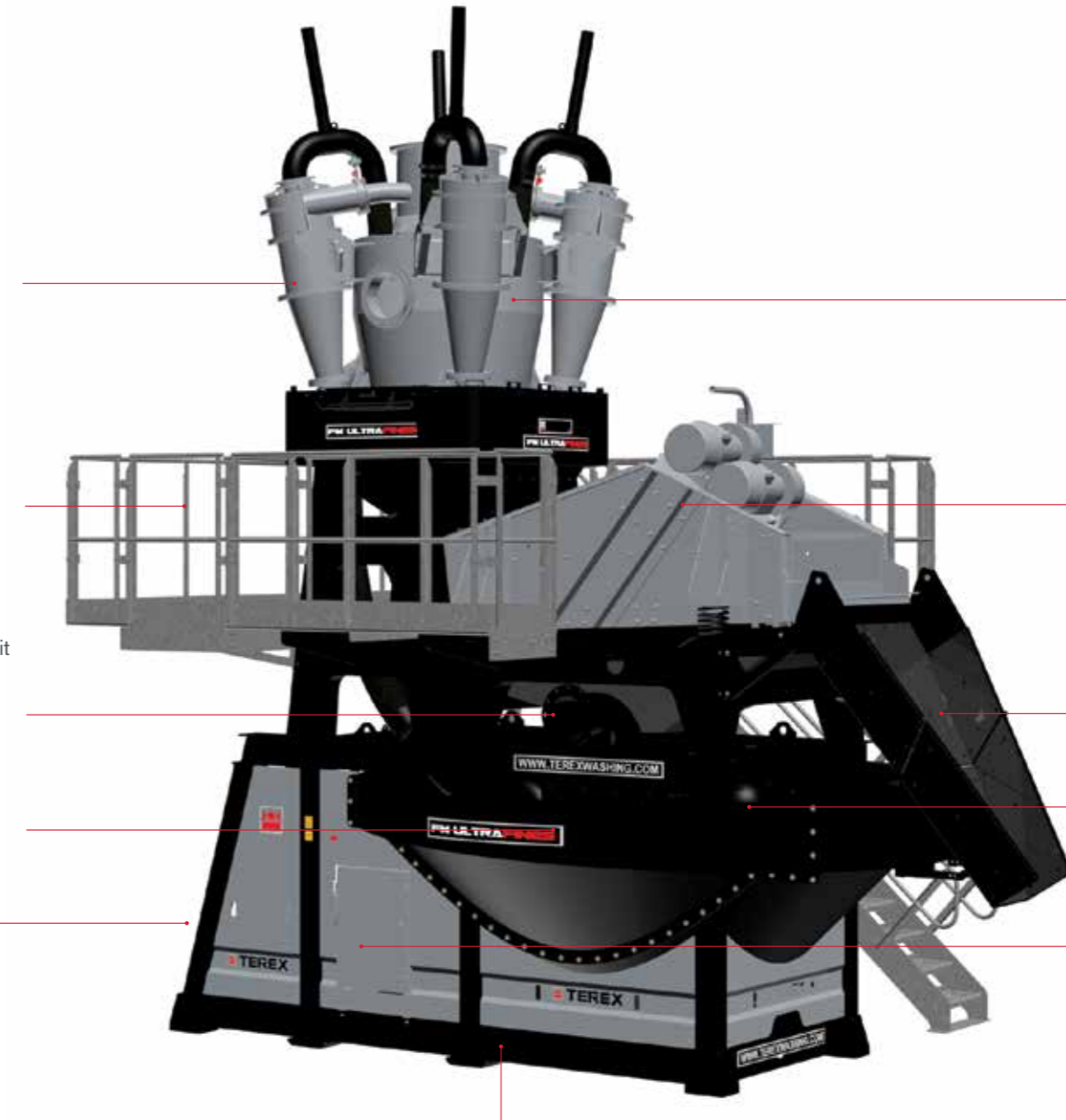

- Fully lined cyclone discharge box for increased wear-life.
- Quick release lids for inspection and maintenance.

- High frequency dewatering screen optimising superior moisture reduction.

- Full width PU media for quick change outs.

- Low friction discharge chute with angle adjustment.

- Self regulating float level system provides consistent tank volume and pump run-dry protection.

- Wired to isolators or fully enclosed control panel to integrate with other Terex Washing Systems equipment.

- Raised chassis design for wash down.

FINESMASTER

FM Direct Feed FM 60DF / FM 120DF / FM 200DF

The FM Direct Feed™ allows economical washing and sand processing to happen on a very small footprint. The unit is suitable for pre-screened material with minimum oversize and is especially suited to dust washing applications.

The FM Direct Feed is a compact sand plant that works on the principle that a dry pre-screened feed is delivered to the wash box equipped with a high pressure spray bar to pre-soak the feed before being delivered to the screen.

It has been introduced for applications where the percentage of oversize in the feed material is minimum.

APPLICATIONS

 AGGREGATES

 RECYCLING

FEATURES AND BENEFITS

Versatile Production

Produces two washed products.

Maximized Material Recovery

Removes silt, slimes & clays for higher-value output.

Strong & Accessible

Durable galvanized steel construction with integrated walkways for easy access and long-lasting performance.

Low Maintenance

Self-regulating sump tank simplifies operation.

Extended Wear Life

Replaceable rubber liners in pumps & cyclones.

Drier, Stockpile-Ready Output

Dewatering screen reduces water content to 10–15%.

Seamless Integration

Pre-wired electric system connects easily with other Terex equipment.



DID YOU KNOW?

We have a wash plant with a loyal Irish customer that is producing the specialist sand for the prestigious Ryder Cup golf event.

FINESMASTER

FM Bucket Wheel FM 120 BW / FM 200 BW

The Terex® FM Bucket Wheel™ range of sand classification systems are highly efficient dewatering units.

The unit removes silts, slimes and clays from sand to produce up to 2 saleable products in applications including concrete, mortar and asphalt sands, quarry dust/crushed fines, lake and beach sands, silica sand, golf course sands, filter bed sands, recycled materials and iron ore.

The range combines a dewatering bucket wheel(s), a centrifugal slurry pump, hydrocyclone(s), a collection tank and a dewatering screen on a single chassis.

APPLICATIONS

-  **AGGREGATES**
-  **RECYCLING**

FEATURES AND BENEFITS

Flexible Sand Recovery

Processes wet or dry feed with optional bolt-on boiler box.

Maximized Material Yield

Removes silt & slimes for higher-value output.

Reduced Wear & Maintenance

Variable speed bucket wheel minimizes pump & cyclone wear.

Lower Operating Costs

Less fine material discharge cuts water recovery costs.

Easy Operation

Self-regulating sump tank for hassle-free use.

Drier, Stockpile-Ready Output

Dewatering screen reduces moisture to 10–15%.

Seamless Integration

Pre-wired for plug-and-play with other Terex equipment.



Bucket Wheel Sand Plants T 150

The Terex® T Range are mobile bucket wheel dewaterers complete with fines retention screw, twin bucket wheel designed units for the removal of clays, silts and slimes to produce up to 2 grades of sand.

The T Range is designed to operate with maximum versatility and can support different requirements such as maximum retention of fines or maximum disposal of fines.

The T Range can be driven hydraulically from the M Range or from its own optional electric power pack.

APPLICATIONS

-  **AGGREGATES**

FEATURES AND BENEFITS

Flexible Sand Recovery

Processes wet or dry feed with optional bolt-on boiler box.

Drier Final Product

Twin bucket wheel increases drainage time for lower moisture content.

Maximized Fines Recovery

Deep-fluted screw ensures efficient material capture.

Consistent Performance

Anti-turbulence design maintains stable settling conditions.

Versatile Power Options

Runs on electric or hydraulic power for seamless integration.

Low Cost, Low Maintenance

Efficient design minimizes upkeep and operating expenses.

Portable & Static Options

Jacking legs & towbar for easy transport or fixed setup.



FM Pentium

The FM Pentium™ range is a static sand and aggregate washing unit. On a single chassis it can produce one sand and one aggregate. The FM Pentium takes the success of the Fines Master range and builds upon it with its increased production and versatility. The range combines a collection tank, centrifugal slurry pump, hydrocyclone(s) and a dewatering screen. With a feed rate of up to 150tph of pre-screened material the FM Pentium has the ability to produce up to 120tph washed sand.

FEATURES AND BENEFITS

Versatile Production

Produces two washed products.

Maximized Material Recovery

Removes silt, slimes & clays for higher-value output.

Strong & Accessible

Durable galvanized steel construction with integrated walkways for easy access and long-lasting performance.

Low Maintenance

Self-regulating sump tank simplifies operation.

Extended Wear Life

Replaceable rubber liners in pumps & cyclones.

Drier, Stockpile-Ready Output

Dewatering screen reduces water content to 10–15%.

Seamless Integration

Pre-wired electric system connects easily with other Terex equipment.

APPLICATIONS

AGGREGATES

RECYCLING



Sand Screw Plants

SW100 / SW200

The Terex® SW 100 Sandscrew is a single screw fine material washer/classifier/dewaterer. The recommended maximum material size is 3/8" (10mm). The approximate capacity of the SW 100 Sandscrew is 50-100 TPH. The Terex® SW 200 is a twin screw fine material washer/classifier/dewaterer. The recommended maximum material size is 3/8" (10mm). The approximate capacity of the SW 200 Sandscrew is 100-200 TPH.

APPLICATIONS

AGGREGATES

RECYCLING

FEATURES AND BENEFITS

High-Capacity Fines Recovery

Single or twin dewatering screws handle heavy-duty processing.

Strong & Easy to Assemble

Robust steel construction ensures durability and quick setup.

Powerful & Reliable

Independent electric drives deliver max torque under load.

Seamless Integration

Fully electric design connects easily with Terex equipment.

Low Maintenance, Easy Operation

Efficient system minimizes upkeep and downtime.

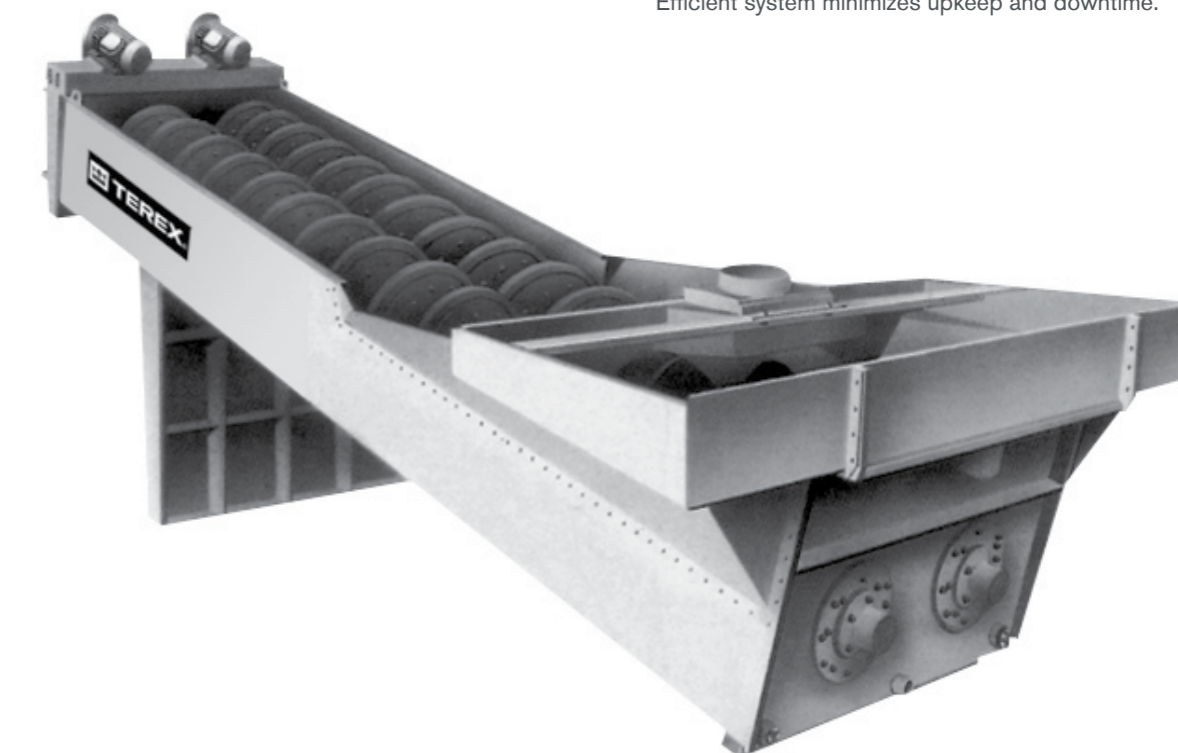



VacRecover

The VacRecover range is a static machine capable of processing wet waste such as Hydrovac, Road Sweepings & Gully waste. A cost and energy efficient machine on a single compact chassis.

The VacRecover range is designed for solids/liquids separation for producing a clean dewatered oversize product and a clean dewatered sand product.

APPLICATIONS

-  **AGGREGATES**
-  **RECYCLING**
-  **WATER MANAGEMENT**

FEATURES AND BENEFITS

Flexible Hopper Configuration

Available with one or two reception hoppers to suit varying operational needs.

Efficient Material Handling

Eliminates double handling of Hydrovac material, streamlining the workflow and reducing labor costs.

Eco-Friendly Operation

Removes the need for disposal ponds, supporting more sustainable and compliant waste management.

High Throughput Capacity

Capable of continuous processing of multiple tanker loads, ensuring minimal downtime and maximum productivity.

Industrial-Grade Design

Engineered for rugged use with easy maintenance access and remote control functionality to ensure maximum uptime.



H RANGE H9 / H12 / H20 / H30

A stand alone hopper designed to provide a constant feed of material to Terex Washing Systems Washplants. A range of different options are available to suit your requirements.

FEATURES AND BENEFITS

Built to Last

Heavy-duty construction for tough environments.

Flexible Power Options

Runs on electric or hydraulic power for complete control.

Customizable Screening

Choice of tipping or vibrating grid to match your needs.

Self-Cleaning Efficiency

Grid bars in various apertures from 75mm to 200mm.

Enhanced Capacity & Durability

Hopper extensions & liners improve wear resistance.

Easy Maintenance

Hinged access for quick servicing.

Seamless Integration

Works effortlessly with other Terex Washing Systems products.

OPTIONS

- Impact rollers
- Wear plates
- Adjustable hopper door
- Single & double deck vibrating grid
- Hopper extensions
- Radio control tipping

APPLICATIONS

-  **AGGREGATES**
-  **RECYCLING**



AggreStac™ 65 / 80 / HLF 75 / LLF 75

The Terex® AggreStac™ is an ideal addition to any Sand or Aggregate processing plant.

This range of Track Mounted diesel powered Stockpiling Conveyors are available in lengths of 65ft or 80ft with the capacity to stockpile up to 400TPH. The compact design allows each unit to transport inside one 40ft container with full hydraulic fold out features for set-up.

With hydraulically adjustable feed and discharge heights, and a range of feedboot linings and extensions the AggreStac allows maximum flexibility to integrate into any existing plant set-up.

APPLICATIONS

 AGGREGATES

 RECYCLING

FEATURES AND BENEFITS

Self-Powered & Mobile

Diesel hydraulic tracked conveyor for easy relocation.

Fast Setup, No Crane Needed

Full hydraulic setup for quick deployment.

Easy Transport & Storage

Compact folding design fits in a container.

Smooth Material Transfer

Adjustable feed height minimizes impact and optimizes flow.

Durable & Customizable

Steel-lined feedboot with optional extensions for extended wear life.

Seamless Plant Integration

Hydraulic angle adjustment from 0° to 28°.

Low Maintenance

Protected power unit with easy service access.

Quick & Controlled Movement

Dual-speed tracks for efficient positioning.



With 400mm dual speed tracks as standard the AggreStac offers speed and control during installation across any terrain



Optional feedboot extensions and liners available to suit a variety of applications



With different scraper and secondary guarding options, the AggreStac can be customised to suit various applications in various regions



The fully enclosed powerunit offers maximum protection while allowing easy access for daily maintenance

TC Conveyors TC 4026 / TC 5032 / TC 6532

The Terex® TC range of conveyors are an integral part of the Terex Washing Systems product range and are constructed to the same high engineering specification. The low-profile, compact design allows portability and versatility, enabling these conveyors to work in compact plant layouts.

The TC range is designed to integrate seamlessly with all the Terex Washing Systems products and are available with either hydraulic or electric drive options.

APPLICATIONS

 AGGREGATES

 RECYCLING

FEATURES AND BENEFITS

High Throughput

Handles up to 300tph for maximum efficiency.

Easy Mobility

Towbar & road wheels for quick transport.

Maximized Storage

Large stockpile capacity reduces handling.

Simple Height Adjustment

Manual hand pump for quick setup.

Flexible Setup

Detachable pivot stand & towbar for easy positioning.



Modular Lattice Conveyors

Terex Washing Systems also offer a range of Modular Lattice conveyors. The intelligent modular design provides belt width options from 500mm up to 1200mm, and the ability to add options such as maintenance platforms and walkways to both sides depending on the application needs.

Electric driven and galvanised as standard, these conveyors can be used as static primary feed or transfer conveyors, or as radial stockpiling conveyors up to 34m in length.

APPLICATIONS

 **AGGREGATES**

 **RECYCLING**

FEATURES AND BENEFITS

Lattice Frame Design

Lightweight yet strong truss-style structure. Reduces overall weight while maintaining rigidity and durability.

Modular Construction

Easy to transport and assemble on-site. Allows for customization in length and height.

High Throughput Capacity

Designed to handle large volumes of material efficiently.

Adjustable Discharge Height

Hydraulic or mechanical systems allow for variable stockpile heights.

Mobility Options

Can be fixed or wheeled.

Belt Width and Speed Variability

Customizable to suit different material types and throughput requirements.

Corrosion-Resistant Materials

Galvanized or painted steel options for harsh environments.



WATERPUMPS

FRESH WATER PUMPS

Terex Washing Systems has a dedicated team of engineers focused on developing applications solutions. Our engineers analyse project requirements to help determine equipment and cost efficiency whatever your pumping requirements. Our cast iron pump has a hard face mechanical seal, mounted on a mild steel base and includes an integrated prime tank.

FEATURES AND BENEFITS

High-Pressure Performance

Pumps up to 5.5 bar (80 PSI) for efficient operation.

Reliable & Efficient Flow

Radial flow impeller ensures smooth performance.

Durable & Long-Lasting

Heavy-duty steel construction for rugged use.

Flexible & Self-Priming

6m suction hose & water tank for easy setup.

Low Maintenance, Low Costs

Designed for easy servicing & efficiency.

Secure & Leak-Proof

Rubber bellows mechanical seal prevents leaks.

Hassle-Free Operation

Foot valve & strainer ensure clean, uninterrupted flow.

VERTICAL SHAFT SLURRY PUMPS

The Terex Washing Systems Vertical shaft slurry pump range provides substantial performance with low power consumption making it one of the lowest running cost pump of its class.

FEATURES AND BENEFITS

Built for Tough Jobs

Handles high-density slurries & large particles with ease.

Prevents Blockages

Integrated agitation vanes keep solids moving.

Reliable & Low Maintenance

Only three main components for simple servicing.

Long-Lasting Performance

High-wear resistant parts extend lifespan.

Hassle-Free Operation

No priming or submerged bearings required.

Works in Any Condition

Ideal for continuous or “snore” operations.

APPLICATIONS

 **WATER MANAGEMENT**

SMART WATER & SLUDGE MANAGEMENT

Reduce Waste, Cut Costs & Maximize Efficiency

At Terex Washing Systems, we provide tailored water and sludge management solutions that eliminate the need for settling ponds, reduce water waste, and lower operational costs.

Eliminate Settling Ponds

Thickeners, filter presses & flocculant dosing systems reclaim water and reduce sludge.

Optimized for Your Materials

Qualified sampling & testing ensure the right solution for your specific feed variations.

Automated Efficiency

Intelligent flocculant dosing adjusts in real time to maximize performance and prevent overuse.

Low Cost, Maximum Recovery

Our range of thickeners & filter presses provide high dewatering efficiency with minimal operating costs.

Scalable & Customizable

From compact solutions to large-scale systems, we match the right setup to your needs.

Smarter water management means less waste, more efficiency, and greater sustainability.

FILTERPRESSES

Elevate your operations with our Filterpress Range, precision-engineered for demanding aggregate and recycling applications, offering high performance, water recovery, and operator safety.

Why a Filterpress:

- A Terex Washing Systems designed and manufactured Filterpress will reduce plant water requirements and minimise waste handling costs. This is achieved through the recycling of up to 95% of plant process water and the filterpress will process sludge into dry solids down to 85%, minimising disposal costs. The Filterpress is a space saving solution when compared to traditional pond systems, which is ideally suited for urban C&D processing sites.



FEATURES AND BENEFITS

Fully Automated

Hands-free operation for maximum efficiency.

Drier Waste, Less Disposal

High-pressure filtration delivers extremely dry cake, reducing waste volume.

Maximised Water Recovery

Reclaims up to 95% of water, cutting usage and costs.

Lower Handling Costs

Reduces silt transport by up to 80%, saving time and money.

Built to Last

Premium components ensure durability and long-term reliability.



THICKENERS

Terex Washing Systems offers a range of Thickener sizes and types to suit a variety of materials and applications. The Terex Washing Systems Applications team balance the client's needs in terms of material type and slurry volume, desired sludge characteristics in order to propose the best thickener for each project.



AQUA CONE

Terex Aqua Cone thickeners are designed and constructed to give optimum performance and reliability even in the toughest applications. The Aqua Cone provides a smaller footprint than a rake style thickener saving space on site. The thickened sludge underflow can reach solids content of over 50%. With no moving parts there is minimal servicing requirement and overall low running costs.

FEATURES AND BENEFITS

High Solids Output

Produces thick mud at 50% solids for efficient waste management.

Lower Infrastructure Costs

Reduces the need for costly concrete basements.

Increased Storage

Extra capacity for mud, minimizing handling.

Ultra-Low Operating Costs

No moving parts, no extraction pump, and minimal maintenance.

Efficient Water Management

Combines thickening & clarification for cleaner water recovery.



RAKE THICKENERS

Terex Washing Systems offers high-rate rake thickeners designed for seamless integration with cyclone-based washing systems, minimizing feed height and reducing the need for additional pumping. Engineered to handle high slurry volumes efficiently, these thickeners accelerate sludge removal with integral scrapers that continuously transport material to the outlet, preventing buildup and improving discharge. Their optimized design lowers operating costs, requiring minimal maintenance while maximizing water recovery and operational efficiency.

FEATURES AND BENEFITS

- 90% of process water recycled
- High capacity flow rates
- Maximum flocculent efficiency
- Consistent underflow



FLOCCULANT DOSING SYSTEM

Optimize your operations and cut costs with our Flocculant Dosing System - precision-engineered for reduced consumption and real-time control.

FEATURES AND BENEFITS

- Automatic dosing system
- Stainless steel construction
- Dry or emulsion based polymer system
- Reduced flocculant consumption by up to 30%





Delivering on
our promises,
so you can
keep yours.



"Increasing our production and our salable material was our reason for looking at a new solution. We initially considered a few at different options, however the reason we opted for this Terex Washing Systems washing solution was due to the capability to make multiple sands and aggregates at any one time and in addition the local dealer support on the ground, which was crucial not only for the build, but for the life-cycle of the plant thereafter."

**Ryan McGuire, Vice President,
McGuire's Excavating & Trucking Inc., USA**



"The Terex Washing Systems equipment has significantly boosted our capacity and efficiency, helping us meet growing demand while aligning with our sustainability goals. It's a key part of our journey to become the UK's leading supplier of sustainable construction materials."

Aggregate Industries Shoreham - UK



"The expansion and modernization of our Bruyères-sur-Oise site marks a major step forward in material circularity. With a new Terex Washing Systems plant, we can now treat up to 400,000 tonnes of material annually and recover 95% of incoming waste—all while operating with a closed-loop water system. This makes our facility the largest and one of the most advanced in Ile-de-France."

EXTRACT - VINCI Construction France



"At Envir, sustainability is at the core of everything we do. With our advanced soil washing plant, we're now able to recover up to 80% of material from contaminated soil — including valuable fine sand. This not only significantly reduces what goes to landfill, but also cuts down on CO₂ emissions and disposal costs. Thanks to Terex Washing Systems' technology, we've transformed how we manage waste, turning a challenge into a circular solution."

Envir, Norway



"The raw material we make our product out of is a little bit different to that of our competitors. To process it, we needed a highly specialised and customised plant and that's where the Terex Washing Systems AggreSand 206 really shines for us."

**Marcus, Co-Founder
Cybersquare, USA**



"This plant is very much tailored to our needs — from the civil layout to the equipment selection, everything was designed with our input and the TWS team delivered exactly what we needed."

**Mike Keohane,
Keohanes, Ireland**



"The customer is very pleased to have a solution in place to recycle their C&D and excavation waste. The working relationship between Terex Washing Systems, Avesco and Albin Borer AG has played a huge part in achieving a high level of performance for this plant."

Albin Borer, Switzerland



"Revive Resources is proud to operate Western Australia's first metropolitan hydro wash facility, powered by advanced washing technology from Terex Washing Systems. Our plant effectively separates hydrocarbons, heavy metals, and organic materials from contaminated waste—producing clean, certified sand and aggregate that can be reused across various industries. This approach helps divert valuable materials from landfill and supports a more sustainable future."

Revive Resources, Australia



"With the VacRecover plant, we've turned a messy, costly problem into a clean, profitable solution. It's helped us recover materials we used to throw away—while improving safety and sustainability across our operations."

Cap City Paving, USA



"We're very pleased to have a solution in place that allows us to recycle our C&D and excavation waste. The performance of the plant and our partnership with Terex Washing Systems have been key to making this possible."

SAPA, Geneva, Switzerland



"All in all, we're very happy with the Terex Washing Systems plant - it performs really well, is easy to maintain, and delivers consistent output day after day. The support from the team has been excellent, and I'd recommend them to anyone. They're fair dinkum."

**Ray Brown,
Coastal Concrete & Quarry, Australia**



"The biggest differences from our old plant to the AggreSand 206 Greenline were the improved efficiency of the cyclones and the ease of maintenance. Terex Washing Systems' forward-thinking design has long-term benefits for our operation. Their ongoing support has been excellent, ensuring we maximize our output and efficiency."

**Ben Karreman, Quarry Manager,
Karreman Quarries, Australia**



DISTRIBUTOR NETWORK

Terex Washing Systems partners with qualified and respected organisations worldwide to bring our customers the highest levels of sales and after sales service. Acting as the daily face of Terex Washing Systems in the market these local experts enjoy the full support of the Terex® brand and the commercial advantage that it brings.

We naturally have high expectations and each new dealer is selected on merit and their ability to pro actively develop business in their territory. Potential distributors must have a proven track record and be able to demonstrate their capacity to market, sell and support premium quality and specialised equipment within our relevant sectors.

In addition customers can engage directly with Terex Washing Systems experts to discuss their requirements and collaborate in the development of innovative customer-specific solutions.

This combined offering makes Terex Washing Systems the intelligent choice for customers who understand how expert knowledge and a genuine product support infrastructure on their doorstep helps maximize return on investment.

As part of the Terex® dealer family you can expect our fullest support at every step, from building your Terex Washing Systems business plan to installing your first equipment and for many years to come. These trusted and lasting relationships have made us a true Global leader and have helped drive many of our innovation and product development initiatives.

With you every step of the way

AUTOMATION & CONTROL

Smarter, Simpler, More Efficient

At Terex Washing Systems, we provide automation solutions tailored to your needs—from basic, easy-to-use controls to fully automated smart systems that enhance efficiency, safety, and performance.

Simple & Reliable Control

Basic relay-logic panels manage motors, pumps, and valves with ease.

Advanced Automation for Maximum Efficiency

PLC & HMI systems offer full plant automation, reducing manual intervention and optimizing performance.

Seamless Integration

Developed in-house to ensure compliance with safety standards and ease of use.

Real-Time Monitoring

Remote telemetry & radio control provide live operational data, alarms, and tonnage per hour for better decision-making.

Reduced Downtime

Automated systems improve reliability, detect issues early, and streamline operations.

Whether you need simple controls or full automation, Terex Washing Systems delivers user-friendly, high performance solutions to keep your plant running smoothly.



Central control panel for typical large washplant installation



Aggresand™ Control Panel



Local machine control panel



H12 Feeder Control Panel

STREAM

Smarter, More Efficient Plant Management

STREAM™ by Terex Washing Systems puts real-time machine and production data at your fingertips, helping you reduce downtime, increase efficiency, and simplify maintenance.

Real-Time Insights

Monitor machine performance, production output, and maintenance schedules through an intuitive dashboard.

Predictive Maintenance

Get timely alerts to prevent unexpected breakdowns and extend equipment life.

Mobile Access

Manage tasks, track records, and receive notifications on the go via the mobile app.

Seamless Integration

Connect with other Terex telemetry systems for a complete operational overview.

Remote Support & Troubleshooting

Quickly resolve issues with remote HMI training, fault finding, and parameter adjustments.

Simplified Maintenance

Log daily checks, schedule lubrication, and assign tasks for streamlined service management.

STREAM™ is designed to empower operators, improve efficiency, and maximize uptime—all from one easy-to-use platform.

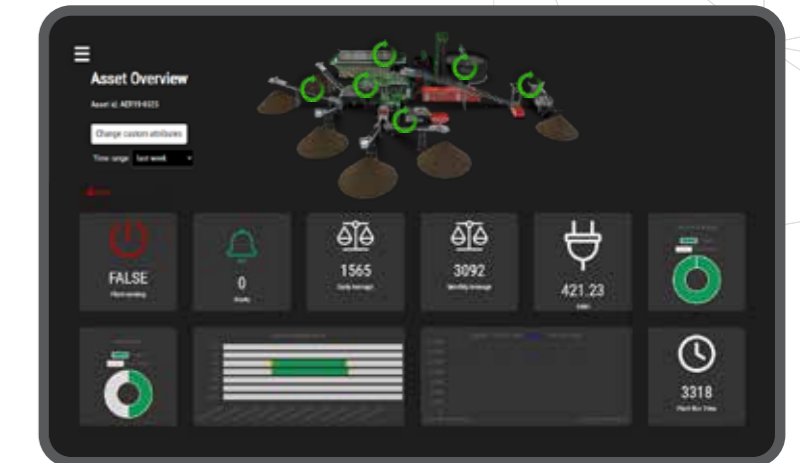



FINANCE

Flexible Finance Solutions

At Terex Financial Services (TFS), we make it easier to invest in the right equipment while managing cash flow and preserving capital. Our flexible financing and leasing options are designed to work around your budget, so you can focus on growing your business.

Fast & Simple Financing

Unlike traditional lenders, we understand your industry and offer tailored solutions with minimal hassle.

Upgrade with Ease

Our trade-in programs help you transition from old equipment to new without financial strain.

Ownership & Lease Options

Choose from flexible purchase and leasing plans that best suit your business needs.

Better Cash Flow Management

Structured finance solutions help free up working capital for other investments.

One-Stop Shop

Work directly with industry experts who handle everything from equipment valuation to resale.

With competitive rates, tailored payment plans, and unmatched industry expertise, TFS gives you the financial flexibility to build your fleet without the stress.

Contact us today at
TWS.sales@terex.com
to discuss your finance options.



**DEDICATED TO WASHING,
DEDICATED TO YOU.**

 **TEREX**[®]

 **WASHING
SYSTEMS**

32 Farlough Road,
Dungannon,
Co. Tyrone,
Northern Ireland, BT71 4DT

Tel: +44(0) 28 8771 8500
Email: TWS.sales@terex.com



www.terexwashing.com

Specifications are subject to change without notice and should be confirmed with Terex Washing Systems before final purchase to ensure accuracy and suitability for your requirements.

@TerexCorporation2025