

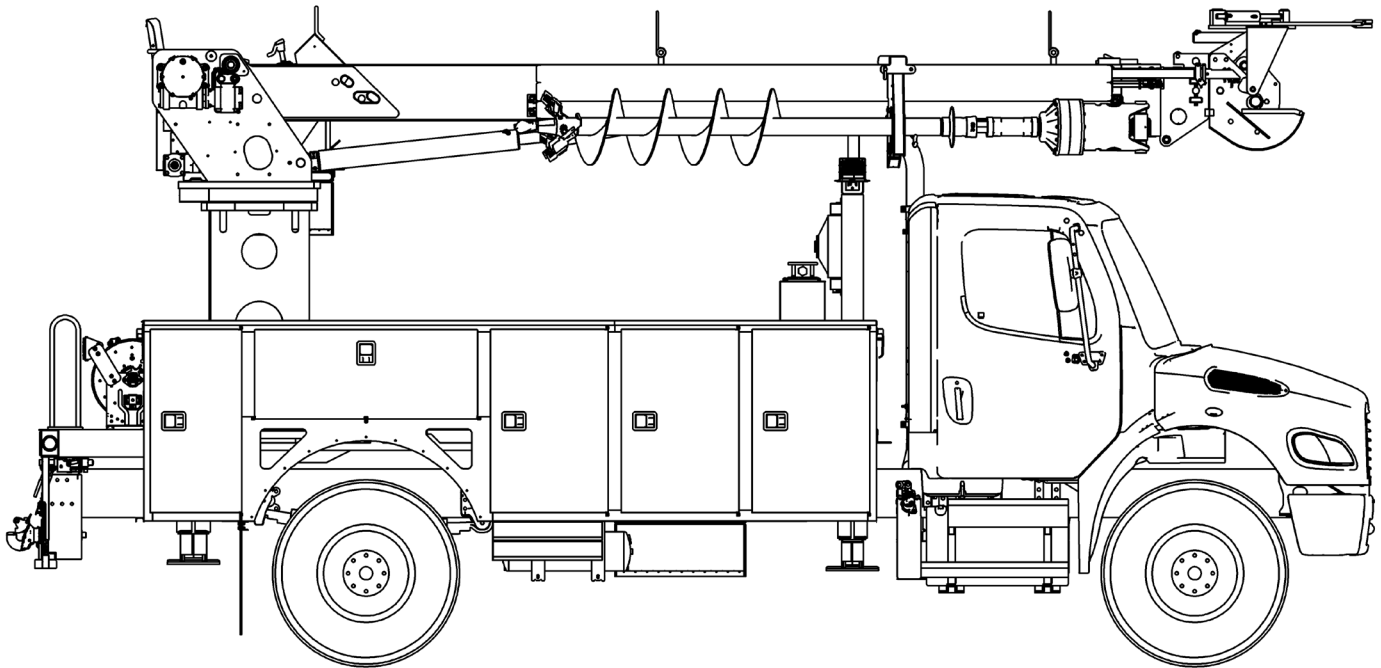

TECH TIPS

SETTING BOOM HYDRAULIC OVERLOAD PROTECTION (HOP)

NO. 10



SERVICE CALL:
SETTING BOOM HYDRAULIC
OVERLOAD PROTECTION (HOP)



MODEL(S):
C3000, C4000, C5000, C6000,
C7000, L4000, XL4000, AND
COMMAND-ALL



TOOLS NEEDED:
1/2", 9/16", 3/4", 1" WRENCHES
1/4" ALLEN WRENCH
1/4" JIC PLUG
0-5000 PSI PRESSURE GAUGE

TEREX UTILITIES TECHNICAL SUPPORT TEAM

PHONE: 1-844-TEREX4U (1-844-837-3948) | EMAIL: UTILITIES.TECHSUPPORT@TEREX.COM

! WARNING



Injection Hazard
Fluid escaping under pressure can penetrate skin and result in death or serious injury.

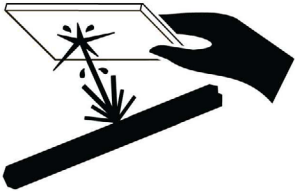

Relieve pressure before disconnecting hydraulic lines.
Stay clear of leaks and pin holes. Use a piece of cardboard or wood to search for leaks. Do not use hand.
Fluid injected into skin must be surgically removed within a few hours by a doctor familiar with this type of injury, or gangrene will result.



DANGER

Failure to obey the instructions and safety rules in the appropriate Operator's Manual and Service Manual for your machine will result in death or serious injury.

Many of the hazards identified in the Operator's Manual are also safety hazards when maintenance and repair procedures are performed.

DO NOT PERFORM MAINTENANCE UNLESS:

- ✓ You are trained and qualified to perform maintenance on this machine.
- ✓ You read, understand and obey:
 - manufacturer's instructions and safety rules
 - employer's safety rules and worksite regulations
 - applicable governmental regulations
- ✓ You have the appropriate tools, lifting equipment and a suitable workshop.

The information contained in this Tech Tip is a supplement to the Service Manual. Consult the appropriate Service Manual of your machine for safety rules and hazards.



TECH TIP 10 | RELEASED 03.18.2026 | VERSION 1.3
©TEREX UTILITIES. ALL RIGHTS RESERVED

CONTENTS

TECH TIP#10

4

| Determine Gauge Location

**VIDEO TECH-TIP
STEP 1**

6

| Install the pressure gauge

| Bleed air from the hose

| Disconnect 1/4' hose from rod side of lift cylinder

STEP 2 - STEP 3

7

| Operate unit to bring the hyd fluid to operating temp

| Test pressure settings and adjust

STEP 4 - STEP 7

8

| Change adjustment as needed

| Retest

| Tighten down jam nuts and verify settings

STEP 8 - STEP 10

VIDEO TECH-TIP

A **video tech-tip** is available as a reference to this written procedure.

- Repair procedures shall be completed by a person trained and qualified on the repair of this machine.
- Immediately tag and remove from service a damaged or malfunctioning machine.
- Read this procedure completely and adhere to the instructions. Attempting shortcuts may produce hazardous conditions.

STEP 1

Determine gauge installation location:

- Use port G1 on HOP manifold for Boom HOP
- Use port G2 on HOP manifold for Rotation HOP

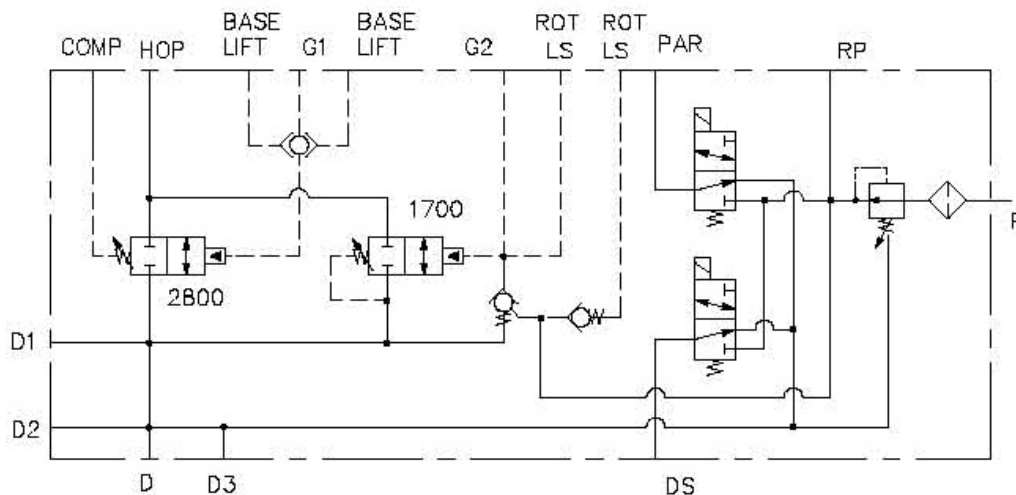

COMP	Rod side of lift cylinders
HOP	To dump cartridges on control valve
Base Lift	To lift cylinder base end
G1	Gauge port. Normally plugged
Base Lift	To lift cylinder base end
G2	Gauge port. Normally plugged
Rot. LS	Sensing line from gearbox
Rot. LS	Reduced pressure to gearbox
PAR	Pressure auger release
RP	Reduced pressure in
P	Pressure in
DS	Digger shift
D,D1,D2,D3	Low pressure drains

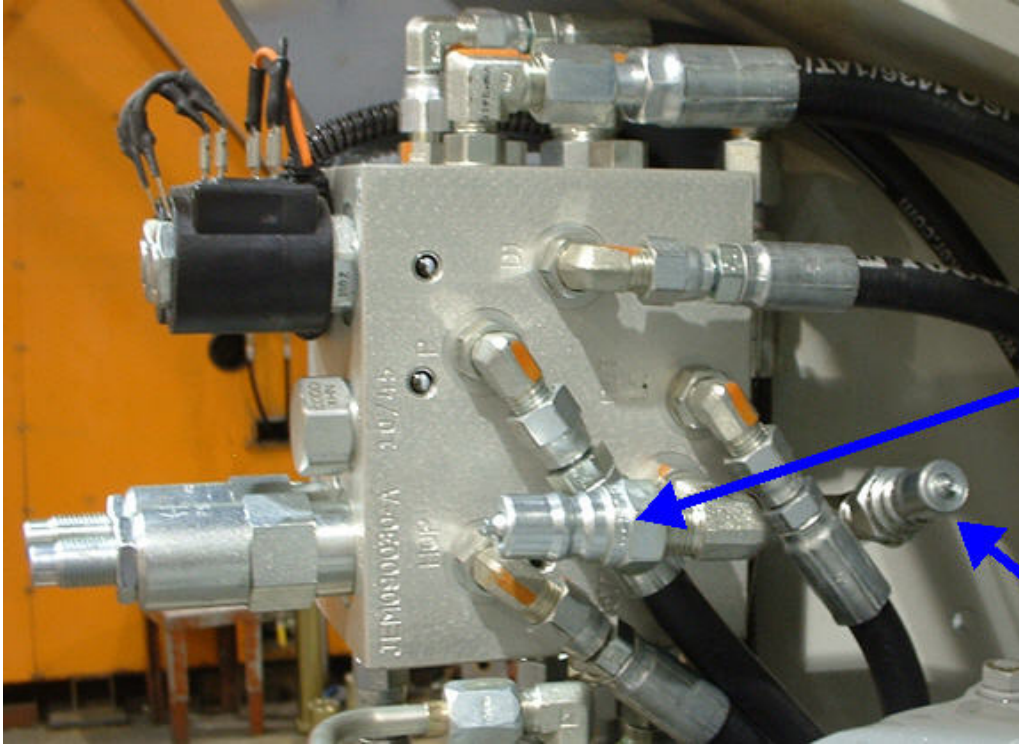

485770 HOP Manifold Shown for G1 Location (2006 units and newer)

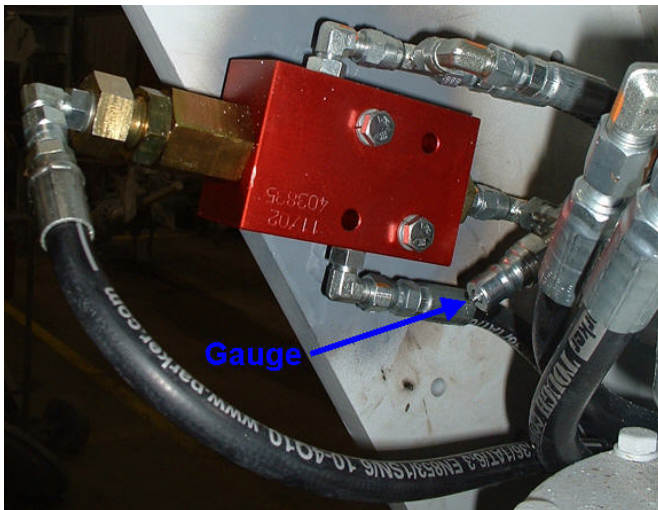

403835 HOP Boom Sensing Valve - Old

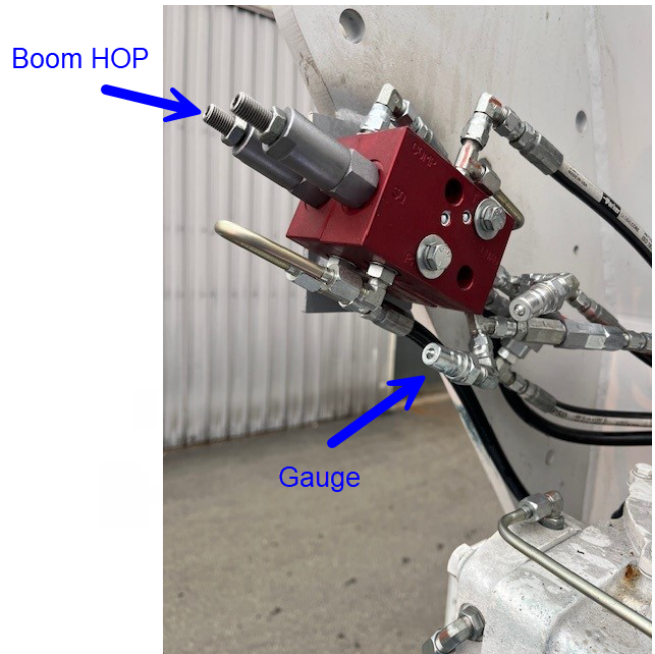

403835 HOP Boom Sensing Valve - Current

STEP 2

Install the pressure gauge in the location indicated in step one (G1 or G2). The maximum hose length is 4 feet. Bleed air from the hose to ensure an accurate reading. The boom must be supported by the boom rest or the lift cylinders must be retracted fully before attempting to install the gauge.



Escaping fluid under pressure can penetrate skin causing serious injury.

Relieve pressure before disconnecting hydraulic lines. Keep away from leaks and pin holes. Use a piece of cardboard or paper to search for leaks. **DO NOT** use your hand.

STEP 3

Disconnect $\frac{1}{4}$ " hose from the rod side of the lift cylinder to the "COMP" port on the HOP manifold or the 90-degree fitting on the Sensing Valve. Plug the hose only with $\frac{1}{4}$ " JIC plug.

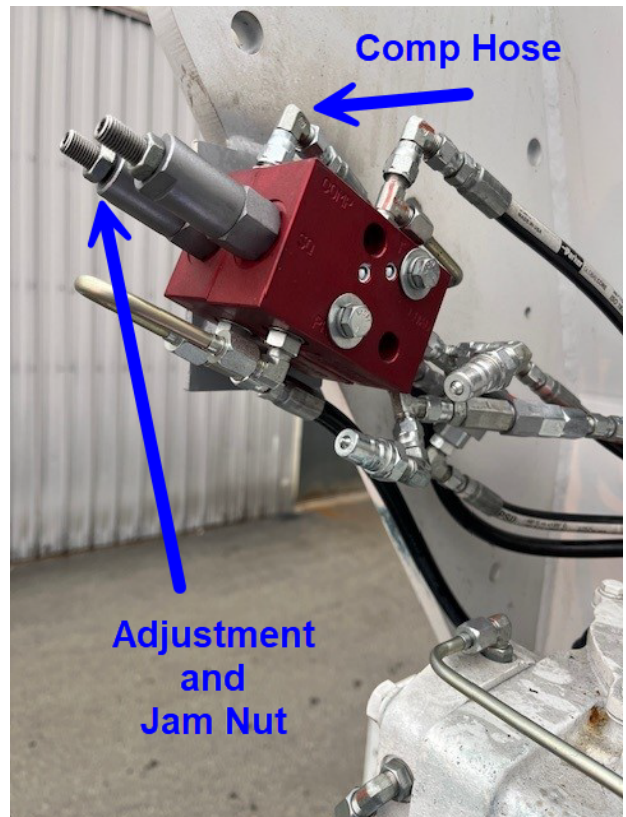
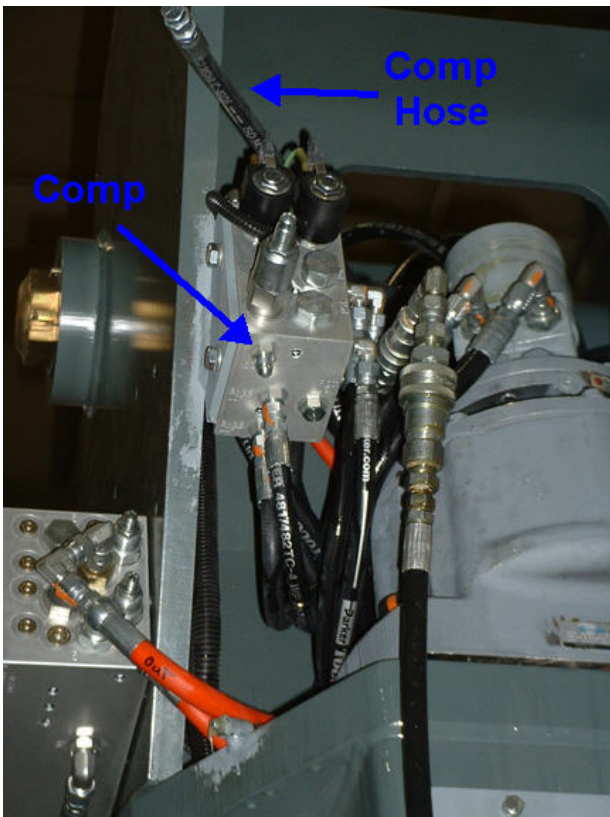

STEP 4

Operate the unit to bring the hydraulic fluid to normal operating temperature.

Raise the boom up to full elevation, set the throttle to the maximum setting, and engage the lift up control.

Verify on the pressure gauge that the setting is at the pressure shown on the unit placard.

If pressure is not at the correct value, see Tech Tip #2 for setting System Relief Valve Pressure or Lift Relief for later C5000, C6000, and C7000 models as indicated on the ID placard or referenced in the unit specific Maintenance Manual.

STEP 5

Raise the boom up to 45 degrees and fully extend the second section. Hook the load line on to a weight heavy enough to dump HOP without raising the load. Reference the load chart to determine this value.

STEP 6

Winch up while monitoring the gauge, it should dump at 200 psi over the pressure recorded in Step 3. If the pressure exceeds 250 psi over the pressure in Step 4, stop and adjust the setting downward before proceeding. Adjust as required until it dumps at 200 psi over.

STEP 7

Adjust PS 2 CW to increase and CCW to decrease pressure, on 485770 HOP Manifold.

See STEP 8 for picture of 403835.

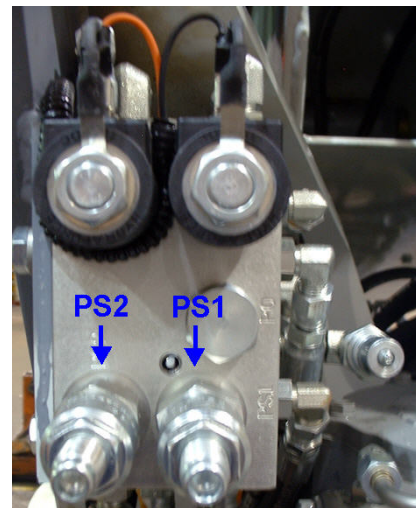

Escaping fluid under pressure can penetrate skin causing serious injury.

Relieve pressure before disconnecting hydraulic lines. Keep away from leaks and pin holes. Use a piece of cardboard or paper to search for leaks. DO NOT use your hand.

STEP 8

Change the adjustment by turning the 1" adjustment nut CW to increase and CCW to decrease, breaking loose the jam nut first.

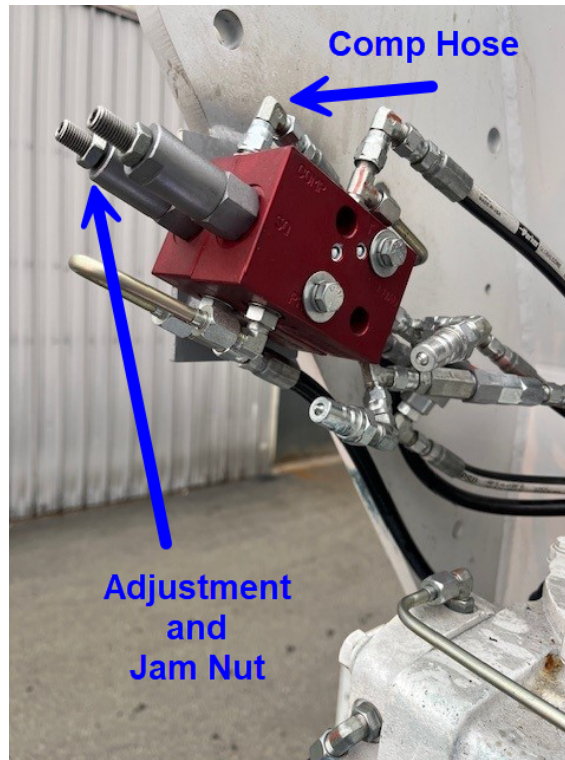

STEP 9

Repeat steps 6 and 7 until properly set.

STEP 10

Tighten down jam nuts and verify settings and place boom in rest. Remove the test gauge and reconnect 1/4" hose from rod side of lift cylinder to "COMP" port or 90-degree fitting.



Escaping fluid under pressure can penetrate skin causing serious injury.

Relieve pressure before disconnecting hydraulic lines. Keep away from leaks and pin holes. Use a piece of cardboard or paper to search for leaks. DO NOT use your hand.



FOR FURTHER ASSISTANCE,

CONTACT THE TEREX UTILITIES TECHNICAL SUPPORT TEAM

PHONE: [1-844-TEREX4U \(1-844-837-3948\)](tel:1-844-TEREX4U) | EMAIL: UTILITIES.TECHSUPPORT@TEREX.COM
