

**Service Call:** Roller and wear pad maintenance and adjustments for Telescopic boom.

**Tools Required:**

5 mm Allen wrench  
8 mm wrench or socket  
13 mm wrench or socket  
19 mm wrench or socket  
Flat blade screw driver  
Soft face hammer  
Lifting strap  
Capable lifting device

**Model(s):**

TL17i Swing Arm  
TL 40 through TL 60

## Tech Tip Safety Rules



### **Danger**

Failure to obey the instructions and safety rules in the appropriate Operator's Manual and Service Manual for your machine will result in death or serious injury. Many of the hazards identified in the operator's manual are also safety hazards when maintenance and repair procedures are performed.

### **Do Not Perform Maintenance Unless:**

- You are trained and qualified to perform maintenance on this machine.
- You read, understand and obey:
  - manufacturer's instructions and safety rules
  - employer's safety rules and worksite regulations
  - applicable governmental regulations
- You have the appropriate tools, lifting equipment and a suitable workshop.

The information contained in this tech tip is a supplement to the service manual. Consult the appropriate service manual of your machine for safety rules and hazards.

## **Step 1**

Visually inspect the side rollers and lower rollers for damage. Ensure that the inner boom is centered in the upper outer boom. Rollers and wear pads must be replaced if they become embedded with grit; this can cause damage to the fiberglass boom. If the fiberglass is damaged it may require cleaning, inspection, and possibly refinishing.

## **Step 2**

The rollers and wear pads guide the inner boom in and out. These will need to be adjusted or replaced as necessary. A clearance of 1/16" (1.6 mm) or more is considered excessive.

## **Step 3**

Refer to the mechanical component maintenance section, lube chart and kit sheets in the unit specific manuals for upper boom assembly torque specs.

## Step 4

If the side and lower rollers need adjustment or replacement, support the inner boom to be centered in the upper outer boom. To achieve maximum contact between rollers and the fiberglass boom, add or remove shims as needed.



## Step 5

To access the lower roller assembly, remove the four side rollers and top wear pad. Using proper rigging, lift the inner boom until it touches the top of the upper outer boom. Be careful not to damage the gel coat or the fiberglass boom.



## Step 6

Remove dust caps to access the shaft retainer bolts.



Use two wrenches, one on each side of the roller shaft. The bolts have thread locker on them. Remove a bolt from the shaft and slide out the shaft away from the rollers and shims. The shims are located between the cone bearing and spacer.

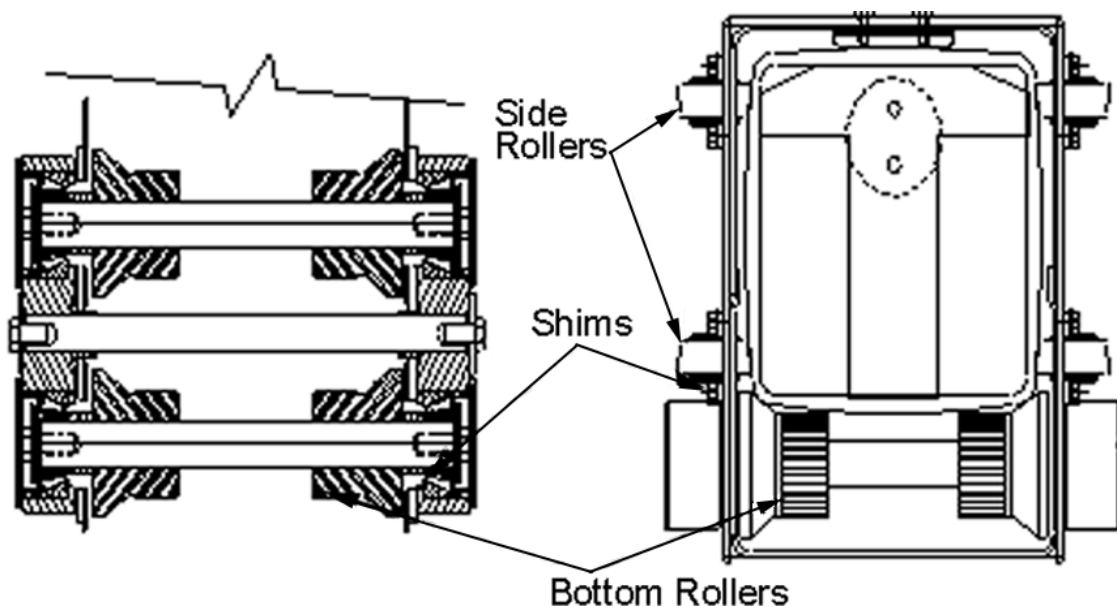

**Note:** Reference the model specific kit sheet for specific install information.

## Step 7

Inspect cone bearing and apply grease as per lubrication chart prior to assembly.

## Step 8

Reassemble the lower roller assembly in reverse order. Shim as required to make maximum contact of the roller to the boom.



## Step 9

With the side rollers removed, inspect rollers, shaft, shims, thrust washers and manufactured angle for wear or damage. Adjust or repair as necessary. Prior to reassembly apply grease per the unit specific lubrication chart.

## **Step 10**

Reassemble in reverse order. Shim as required so the boom is centered in outer boom.

If you have any questions please contact 1-844-TEREX4U (1-844-837-3948). Please have the model and serial number of the unit available.