

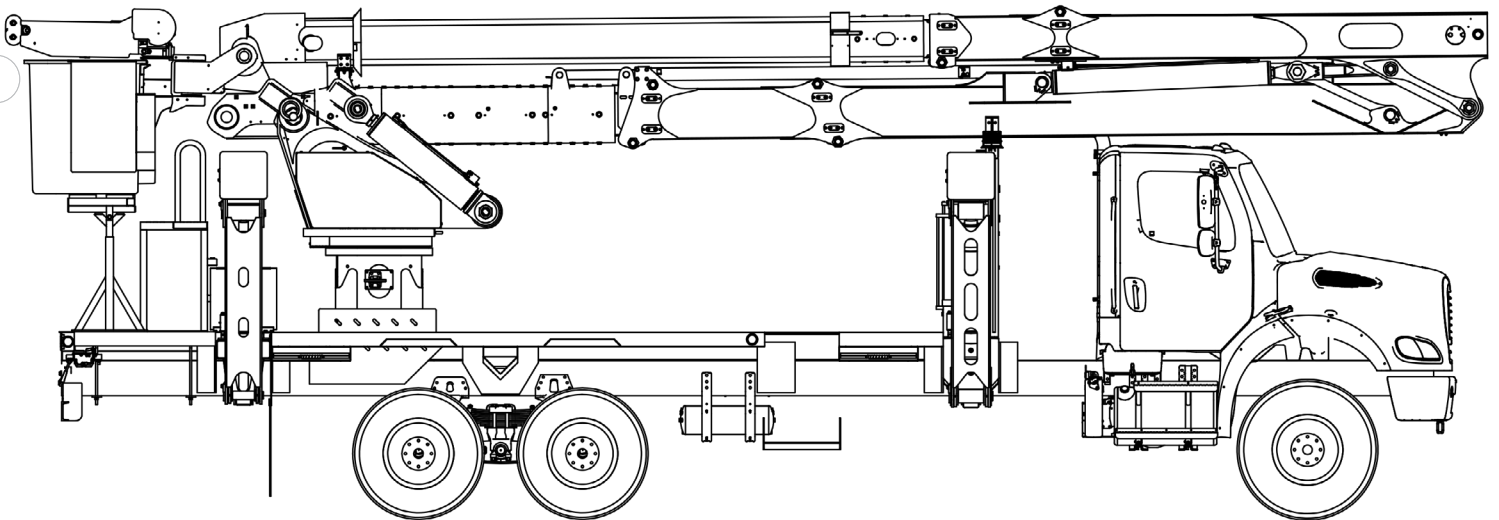

TECH TIPS

TM LEVELING GEARBOX INSPECTION/REBUILD

NO. 120



SERVICE CALL:
TM LEVELING GEARBOX
INSPECTION/REBUILD



MODEL(S):
TM WITH END MOUNT
PLATFORMS



TOOLS NEEDED:
SEE INTRO

TEREX UTILITIES TECHNICAL SUPPORT TEAM

PHONE: 1-844-TEREX4U (1-844-837-3948) | EMAIL: UTILITIES.SERVICE@TEREX.COM



DANGER

Failure to obey the instructions and safety rules in the appropriate Operator's Manual and Service Manual for your machine will result in death or serious injury.

Many of the hazards identified in the Operator's Manual are also safety hazards when maintenance and repair procedures are performed.

DO NOT PERFORM MAINTENANCE UNLESS:

- ✓ You are trained and qualified to perform maintenance on this machine.
- ✓ You read, understand and obey:
 - manufacturer's instructions and safety rules
 - employer's safety rules and worksite regulations
 - applicable governmental regulations
- ✓ You have the appropriate tools, lifting equipment and a suitable workshop.

The information contained in this Tech Tip is a supplement to the Service Manual. Consult the appropriate Service Manual of your machine for safety rules and hazards.



TECH TIP 120 | RELEASED 4.29.2024 | VERSION 1.1
©TEREX UTILITIES. ALL RIGHTS RESERVED

CONTENTS

TECH TIP #120

4

| *Tools required*

| *Parts needed*

INTRODUCTION

5

| *Gearbox rebuild*

STEP 1 - STEP 26

15

APPENDIX A

Tools Required

Torque Wrench capable of, 80 ft-lbs., 170 ft-lbs., and 680 ft-lbs.
Allen Head Socket Set up 3/8"
Socket Set up to 15/16"
Wrench Set up 1"
2 -4 JIC caps and plugs
1 1/2" Socket
Pry Bar, Hammer, and Brass Drift
Chisel Set and Bearing Puller
Chain Wrench
300# to 400# weight
Penetrant Oil

Parts Needed

473908 x 12
30081 x 8
608603 Bearing x 1
474288 Bearing x 1
488896 Shims x 13
488897 Shims x 7
474265 Bearing
Polygon x 4
Mobilux EP023, 3 quarts
Blue RTV
Loctite SI 5015
Red and Blue Loctite



The parts listed above may be replaced during inspection or rebuild, see the following kit-sheets for more information.

The following instructions are for disassembly for inspection and rebuild as needed.

Appendix A

STEP 1

Set the unit in the ground mount position. Position an outrigger pad or another protective covering under the platform to protect the bottom from ground damage.

Attach a weight to the jib as shown in the picture below. Do not raise the load off the ground. Place enough tension on the rope to keep the platform from tipping backwards when removing the bolts on the leveling arms.



STEP 2

Remove the clamp holding the hoses to the platform shaft.

Then remove the boom tip covers, leveling arm covers, and the 4 - 1" bolts holding the platform rotation bracket to the leveling arms.



STEP 3

Using the upper controls, move the upper boom away from the boom tip assembly and retract the boom until it is in a comfortable position to disassemble the leveling gear box.

Spray leveling arms where the keys and shaft come together with penetrant oil to help loosen the arms from the shaft. Remove ½" bolt holding leveling arm to shaft and both limit system valves from the gear box.



STEP 4

Remove leveling arms from the shaft. Inspect the condition of the keys and place them in a bag for use during reassembly if they are in usable condition.

Remove the hoses from the leveling motor then remove level motor and speed reducer from the gearbox.



Escaping fluid under pressure can penetrate skin causing serious injury.

Relieve pressure before disconnecting hydraulic lines. Keep away from leaks and pin holes. Use a piece of cardboard or paper to search for leaks. **DO NOT** use your hand.



STEP 5

Place a drip pan below the gear box and remove the cover plate. Use a sharp chisel to help pry the cover plate off.



STEP 6

Remove bottom bearing plate from the gear box.



STEP 7

Use the chain wrench to rotate the gear to remove the worm out the top side.

Now pull the gear and shaft out of the gear box.



STEP 8

Remove the small bearing race on the bottom side of the gear box. Clean all parts and the inside of gear box, then inspect. Tap all holes out to clean the old Loctite out of them and then spray with brake clean to further clean them.

STEP 9

Clean all surfaces free of the blue RTV Sealant and inspect all internal parts. If any damage is found on the spacers, Z-Kit 1589 can be ordered.

If you have any questions, contact Terex Utilities Technical Support at 1-844-Terex4U (1-844-837-3948) or utilities.service@terex.com.

STEP 10

Remove the fiber bearings from the gear box and boss plate by pounding them out with a hammer and brass drift.



Clean and install new bearings.



STEP 11

Put the gear and shaft on the workbench and inspect the gear for cracks and wear.

Note: If the gear is cracked the gear must be replaced, it cannot be rotated.

The minimum thickness of the gear is: 0.054.

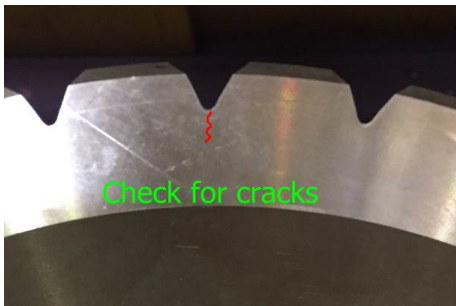

If no cracks are found and the gear shows minimum wear, it may be reinstalled as is. If the thickness is less than .054, rotate the gear on the shaft 180 degrees.

Mark the gear with a center punch in line with the bolt hole in the shaft.



STEP 11 (Continued)

Remove the 12 bolts holding the gear onto the shaft, tap out the hole in the mounting plate on the shaft and clean with brake clean.

Rotate the gear so that the center punch mark is 180 degrees from the bolt hole. Place the mounting spacer ring onto the gear.

Red Loctite the new bolts and torque to 80 ft-lbs. using the crisscross method show below.

Recheck the torque on all bolts to make sure that the bearing is seated onto the shaft.

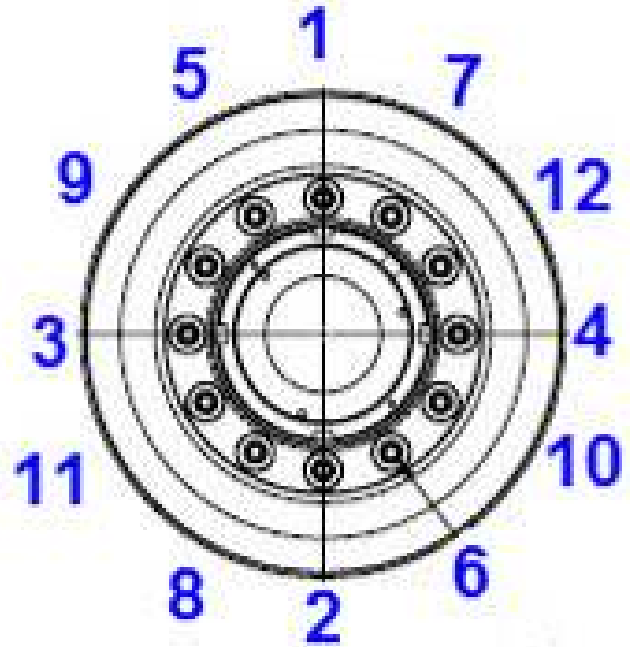

STEP 12

Using a wire wheel or emery cloth, clean the leveling shaft to prevent damage to the new fiber bushings when reinstalling into gear box and boss plate.

STEP 13

Grease both spacers inside and out that go on both sides of the gear.

STEP 14

Install the small bearing race into the gearbox so that the cone is facing the inside of the box.



Slide ring gear assembly into the gear box.

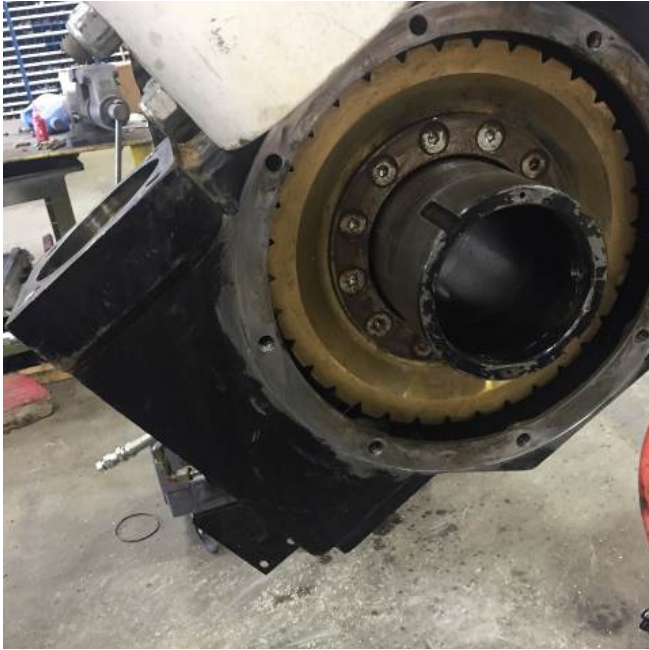

STEP 15

Install bearing onto the worm shaft, then install the worm shaft into the gearbox. The gear assembly will need to be rotated to slide down.



STEP 16

Install the bearing race and machine bushing into the gearbox.



STEP 17

Install the speed reducer into gear box with 2 bolts to tighten it down. Do not use the RTV sealant yet. Install the end cap and tighten the bolts.

Use a feeler gauge and measure the gap in between the end cap and the gear box housing and record the measurement.



STEP 18

Using a micrometer, measure the shims to the same amount as the measurement of the feeler gauge minus .005. The .005 gap provides space for the RTV sealant.



STEP 19

Reinstall the end plate and torque to 170 ft-lbs. with red Loctite.

Remove the speed reducer and motor and rotate gear assembly so that the machine bushing and race can be removed.

STEP 20

Using the blue RTV Sealant, seal the boss cover. Install the cover and torque the boss cover plate bolts to 80 ft-lbs. with red Loctite.

STEP 21

Fill the gear box with 3 quarts of EP023 Gear Lube through the worm shaft where the top bearing race was removed. Reinstall the bearing race and machine bushing.



STEP 22

Using Blue RTV sealant, seal the leveling speed reducer and torque mounting bolts to 170 ft-lbs. with red Loctite.

STEP 23

Hook up hydraulic lines to the leveling motor. Verify everything has been connected before installing the leveling arms. Manually run the leveling from the servo valve located on the back of the platform. When done, have the bolt hold the leveling arms on pointing straight back.



Escaping fluid under pressure can penetrate skin causing serious injury.

Relieve pressure before disconnecting hydraulic lines. Keep away from leaks and pin holes. Use a piece of cardboard or paper to search for leaks. DO NOT use your hand.

STEP 24

Apply anti-seize onto the inside of the leveling arms and keys. Install arms onto the shaft and start the bolt into the platform shaft. Install the keys one at a time into the leveling arms and shaft.



STEP 25

Operate the unit from the top controls and line the leveling arms up with the platform rotator bracket. Install the 1" bolts into the leveling arms. Torque the 1" bolts to 680 ft-lbs. with red Loctite.

STEP 26

Reinstall all covers and operate the boom through its full range of motion from the lower controls before operating from the platform.

APPENDIX: A

LEVELING GEARBOX ASSY	
DATE: 11/06/2019	ECN#: 77336
479784 L	

NOTE:

IF HOUSING IS REQUIRED
ORDER NUMBER IS **479784P**.

SEE UPPER BOOM BONDED LEVEL
FOR MOUNTING HOLE LOCATION.

ASSEMBLY NOTES:

- 1 GREASE BEARINGS, WORM GEAR AND GEAR SPACERS LIBERALLY WITH EP GREASE AND ADD MOBILUX EP023 LUBE TO LEVEL SHOWN BEFORE ADDING SIDE COVER.
- 2 PRE-LOAD BEARING .002/-0.002
- 3 TORQUE TO 80 FT-LBS LUBED WITH LOCTITE
- 4 TORQUE TO 170 FT-LBS LUBED WITH LOCTITE
- 5 IF GEAR BOX HOUSING IS REQUIRED MUST BE ORDERED SEPERATE.

ITEM	PART NO	PART NAME	QTY
22	411585	PLUG, HEX, HOLLOW, #8, O-RING	1
21	H25967	SHCS SCREW 0.50-13 X 1.50 X 1.50 ZP	4
20	479848	MOTOR, HYD, 15 CU.IN.	1
19	479853	spacer	1
18	474288	BEARING, ROLLER	1
17			
16	488896	SHIM	13
ITEM	PART NO	PART NAME	QTY

15	488897	SHIM	7
14	498505	5/8-11 X 1.50	4
13	608603	BEARING, ROLLER	1
12	30081	HARDENED FW 0.625 ZP	4
11	38244	SCHC SCREW 0.50-13 X 1.00 ZP	8
10	484863	SPACER, BEARING	1
9	473063	HBOLT 0.625-11 X 2.00 X 2.00 GR8 YZ	4
8	10036	REGULAR LW 0.50 ZP	8
7	479785	RING GEAR ASSY	1
6	479790	BOSS PLATE ASSY	1
5	608604	MACHINE BUSHING	1
4	474263	END CAP	1
3	479570	WORM SHAFT, 34-1	1
2	479849	GEAR BOX, PLANETARY, 4.19-1 RATIO	1
1	479774	GEARBOX HOUSING	REF
ITEM	PART NO	PART NAME	QTY

* SEE SEPARATE ASSEMBLY SHEET

PAGE 1 OF 2

(NS) = NOT SHOWN



RING GEAR ASSY

DATE:
10/12/2015

ECN#:
71006

479785 A

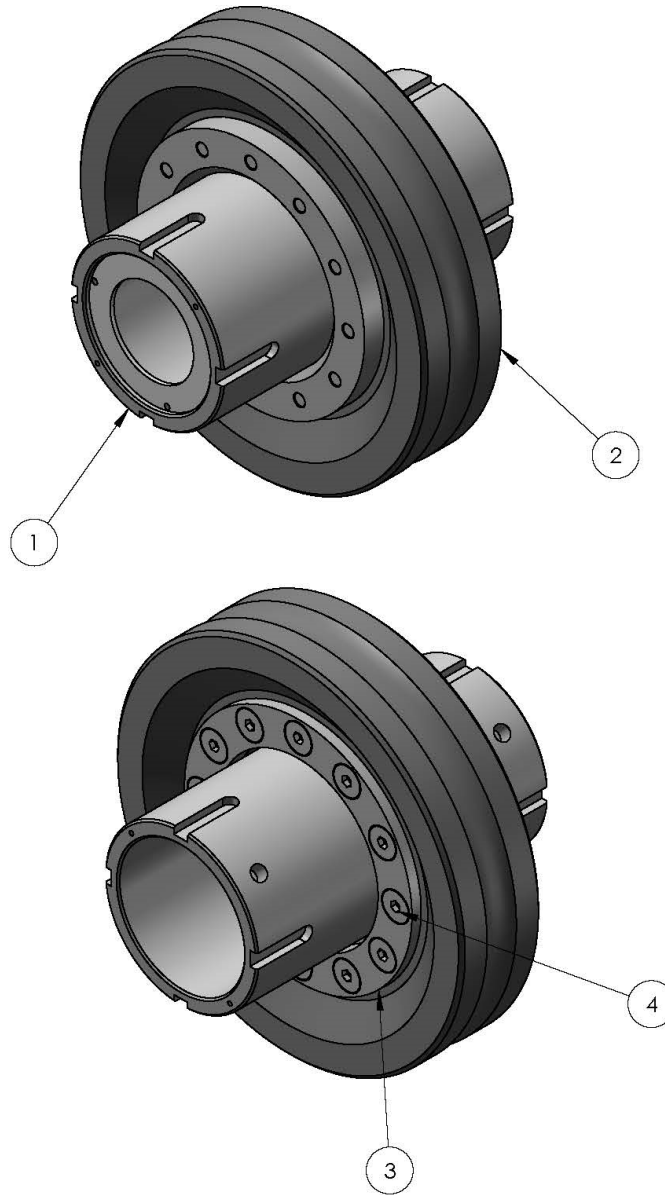

4	473908	SCHCSCREW 0.50-13 X 2.50 X 1.50 ZP	12
3	479787	SPACER RING	1
2	479569	WORM GEAR	1
1	479786	WORM GEAR SHAFT WELDT	1
ITEM	PART NO	PART NAME	QTY

* SEE SEPARATE ASSEMBLY SHEET

PAGE 1 OF 1

(NS) = NOT SHOWN



RING GEAR ASSY

DATE:
01/09/2020

ECN#:
78112

479785 B

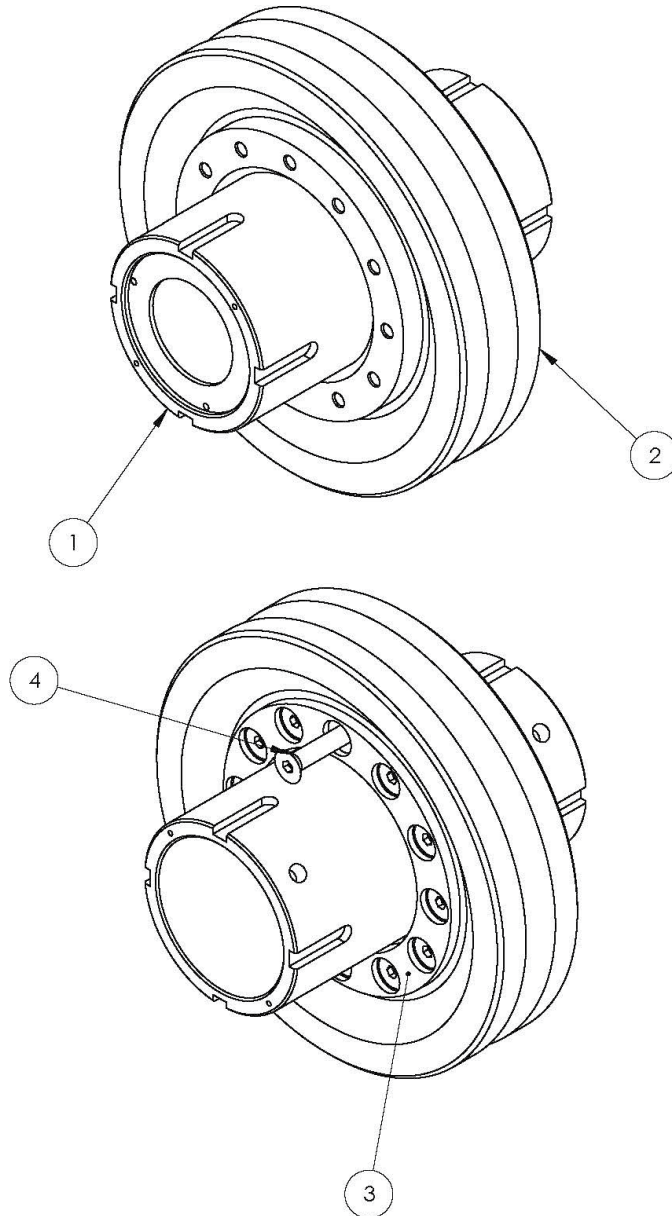

4	626075	SCHSCREW 0.50"-13 NC X 2.25" X 2" ZP	12
3	626073	SPACER RING, BEARING	1
2	479569	WORM GEAR	1
1	479786	WORM GEAR SHAFT WELDT	1
ITEM	PART NO	PART NAME	QTY

* SEE SEPARATE ASSEMBLY SHEET

PAGE 1 OF 1

(NS) = NOT SHOWN



FOR FURTHER ASSISTANCE,
CONTACT THE TEREX UTILITIES TECHNICAL SUPPORT TEAM
PHONE: **1-844-TEREX4U (1-844-837-3948)** | EMAIL: **UTILITIES.SERVICE@TEREX.COM**
