

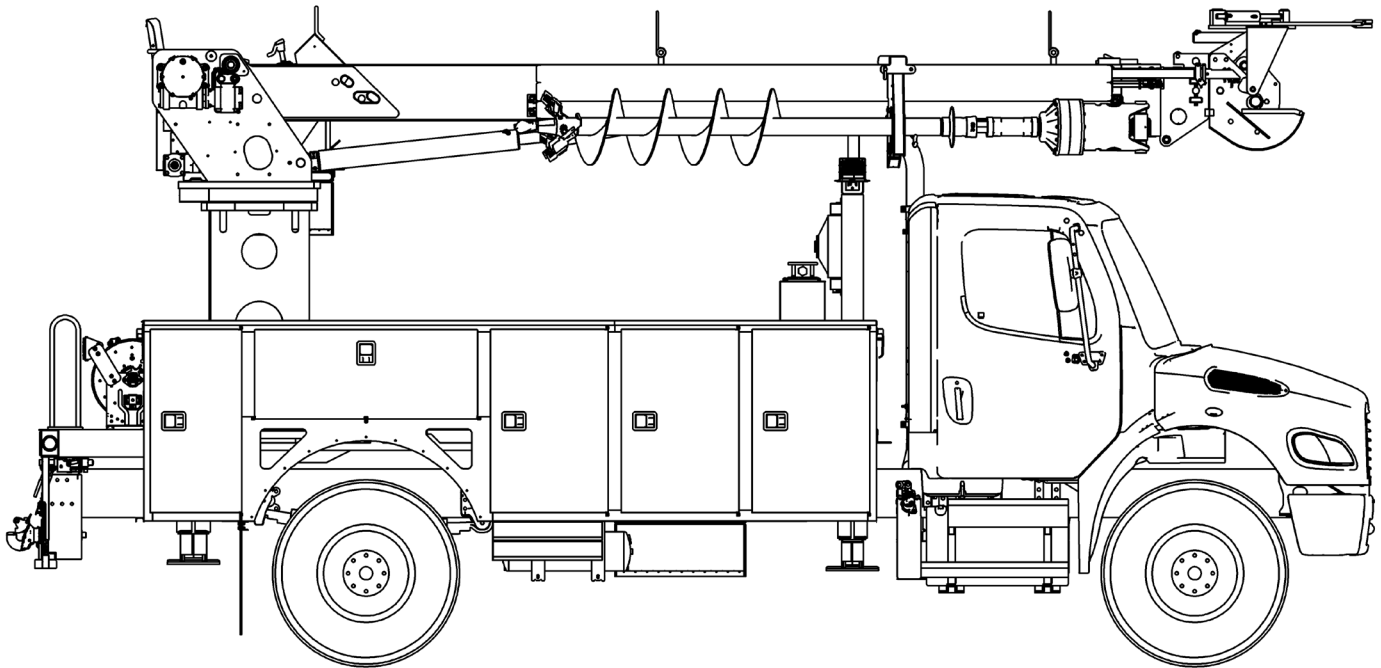

TECH TIPS

TROUBLESHOOTING A DIGGER DRIVE

NO. 13



SERVICE CALL:
TROUBLESHOOTING A DIGGER
DRIVE



MODEL(S):
C4000, C5000, C6000, AND
GENERAL



TOOLS NEEDED:
SEE INTRODUCTION

TEREX UTILITIES TECHNICAL SUPPORT TEAM

PHONE: 1-844-TEREX4U (1-844-837-3948) | EMAIL: UTILITIES.TECHSUPPORT@TEREX.COM

! WARNING



Injection Hazard
Fluid escaping under pressure can penetrate skin and result in death or serious injury.

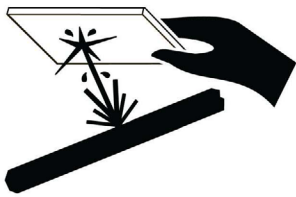

Relieve pressure before disconnecting hydraulic lines.
Stay clear of leaks and pin holes. Use a piece of cardboard or wood to search for leaks. Do not use hand.
Fluid injected into skin must be surgically removed within a few hours by a doctor familiar with this type of injury, or gangrene will result.



DANGER

Failure to obey the instructions and safety rules in the appropriate Operator's Manual and Service Manual for your machine will result in death or serious injury.

Many of the hazards identified in the Operator's Manual are also safety hazards when maintenance and repair procedures are performed.

DO NOT PERFORM MAINTENANCE UNLESS:

- ✓ You are trained and qualified to perform maintenance on this machine.
- ✓ You read, understand and obey:
 - manufacturer's instructions and safety rules
 - employer's safety rules and worksite regulations
 - applicable governmental regulations
- ✓ You have the appropriate tools, lifting equipment and a suitable workshop.

The information contained in this Tech Tip is a supplement to the Service Manual. Consult the appropriate Service Manual of your machine for safety rules and hazards.



TECH TIP 13 | RELEASED 06.12.2026 | VERSION 1.1

©TEREX UTILITIES. ALL RIGHTS RESERVED

CONTENTS

TECH TIP#13

4

| Tools

| Identify the type of digger drive

INTRODUCTION
STEP 1

5

| Common Complaints

STEP 2

7

| Planetary Digger Drives

| 2-Speed Digger Drive

APPENDIX A

9

| Drive and System Components

APPENDIX B

12

| Augers and Toolings

APPENDIX C

INTRODUCTION

Open wrenches up to 1-1/2" and basic hand tools

Calibrated flow meter with built in gauge, flow control shut-off valve to create resistance

JIC plugs and caps of various sizes

STEP 1

Identify the type of digger drive on the unit.

Digger Drives come in different models and are made by several different manufacturers. This section is included to provide additional information on the operation and functionality of the components. To view more information on a specific component or system, select the appropriate link below.

There are three different group styles of the planetary digger drive:

- Single Speed Digger Drive
- Two-Speed Digger Drive with Mechanical Shift
- Two-Speed Digger with Hydraulic Motor Shift



FIGURE 1

Drive and System Components

- Digger Drive Hydraulic System
- Digger Drive Rated Torque
- Flow and Hydraulic Pressure
- Hydraulic Shift Pressure
- Setting the Pressure Reducing Valve
- Augers and Tooling

STEP 2

Troubleshooting a Digger Drive. Common Complaints:

Digger Drive is too slow or has no power

- First check the torque limit valve (over stow valve) located at the auger storage bracket. This will dump the digger dig function if the valve is stuck in the up position.
- Verify the system flow and pressure are set according to the Manufacturer's specifications
- Make sure the unit is operating at the correct engine RPM
- Verify that the auger teeth are not damaged, missing, or excessively worn

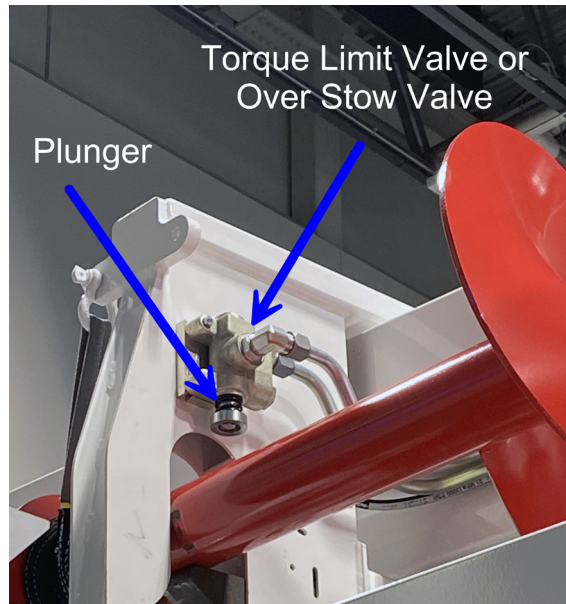

Escaping fluid under pressure can penetrate skin causing serious injury.

Relieve pressure before disconnecting hydraulic lines. Keep away from leaks and pin holes. Use a piece of cardboard or paper to search for leaks. DO NOT use your hand.

STEP 2 (Continued)

Digger Drive does not perform as well as a previous machine

- Verify the system flow and pressure are set according to the Manufacturer's specifications
- Make sure the unit is operating at the correct engine RPM
- Compare the digger specifications of the new and old units
- Verify that the auger teeth are in good condition.

Hydraulic oil gets very hot when using the digger drive

- Verify the system flow and pressure are set according to the Manufacturer's specifications
- Make sure the unit is operating at the correct engine RPM
- Consider the type of terrain the operator has been digging in. With normal terrain, digging a hole can be accomplished in approximately 10 minutes. In excessively rocky or hard terrain, it may take 2 hours or more to finish digging a hole
- Continuously digging for long periods of time can cause the hydraulic oil to become hot
- Size of the auger, if excessive for the auger drive will cause excessive heat.

The digger drive makes a loud grinding noise when shifting speeds; for example, from high to low or low to high.

- Shifter gear may have been damaged by improper shifting, not all digger drives can be shifted "on the fly".

APPENDIX: A

Planetary Digger Drives

Single Speed Digger Drive

A single speed digger drive will only increase speed by raising the engine RPM's to increase the oil flow to the hydraulic motor.

Two-Speed Digger Drive with Mechanical Shift

A two-speed digger drive with mechanical shift has the capability of changing the gear ratio internally using a mechanical shifter, giving the operator the option of running at low speed for high torque or high speed with lower torque.

Note: Due to the mechanical shift on this type of drive, it is NOT designed or recommended that the drive be shifted while the auger is turning (Shift on the fly).

The proper way to shift this type of digger drive is to bring the rotating auger to a complete stop, move the shifter into high or low, and then slowly start to rotate the auger, making sure the gears are fully engaged and have shifted properly. Continuing to grind the gears during shifting will reduce the life of the digger drive. Shifting while rotating, or stalled, under load will cause severe damage.

Decal 617558 can be added near controls to inform users not to shift under load.



Two-Speed Digger Drive with Hydraulic Motor Shift

Two-speed digger drives with hydraulic motor shift have the capability of “Shifting on the fly” without having to stop the digger drive to change the speed. Note: the user may not know which type of auger drive they have, mechanical shift or hydraulic motor shift. It is best to advise to stop rotation before shifting to prevent damage if moving between machines. While all digger drives have one hydraulic motor to drive the digger drive gear box, a two-speed digger drive with hydraulic motor shift has two hydraulic motors to drive the digger drive. The motors are stacked on each other, with the output shafts of the motors connected internally. The speed of the auger is controlled by directing the flow to one or both motors.

If there are 40 GPM (Gallons per Minute) available to the digger drive, a hydraulic directional valve will direct all the flow to the top motor for high speed. In low speed, the flow will be split between the two motors, lowering the speed and increasing the torque.



APPENDIX: B

Drive and System Components

Digger Drive Hydraulic System

A digger drive hydraulic system is usually a very basic hydraulic system consisting of a two-position directional control valve. The direction control valve may be part of the stack valve assembly with an inlet relief valve. When selected the hydraulic oil flows from the directional control valve through hoses and the steel sliding tube oil carrier mounted along the side of the extension boom to the digger drive. If the digger drive is equipped with a two-speed drive there will also be a ½ in. sliding tube as part of the assembly to supply the hydraulic pressure to shift the digger drive from high to low speed. In some units you may also see another ½ in. optional sliding tube used as a digger drive hydraulic motor drain. The motor drain hydraulic line is connected to a free flow port that returns the oil to the hydraulic reservoir with minimum restriction.

Flow and Hydraulic Pressure

In order to get the optimum performance of any digger drive, the flow and pressure must be set to the manufacturer's specifications. For example, some systems require up to 40 GPM of flow and a digger pressure of 2300 PSI. Without the proper flow the digger drive will be slow, without the proper hydraulic pressure setting the digger drive will not be able to develop proper torque and may stall. Operation at higher flow or pressure than set by the manufacturer will shorten the system life and can cause severe damage.

Note: Always read the Maintenance Manual for the unit and verify the pressure and flow for the system and digger drive before you start troubleshooting the digger drive system.

Oil Temperature

Always be sure to measure the temperature of the oil in the hydraulic reservoir using a digital thermometer, such as an infrared thermometer. While the reservoir may be too hot to touch, the oil may still be within the normal operating temperature. Units expected to be operated in high ambient temperature or over long periods of time may optionally have a hydraulic cooler installed to help cool the oil in the reservoir. Make sure the hydraulic cooler is properly sized for the hydraulic system of the unit.

Hydraulic Shift Pressure

A low-pressure hydraulic source is used to shift a digger drive. When pressure is present in the shift line, a hydraulic cylinder or hydraulic actuator will change the digger drive's speed to high.

The pressure to shift will vary from 180 to 350 PSI depending on the unit type and options installed. Always refer to the Manufacturer's Maintenance Manual for proper pressure settings.

The low hydraulic pressure source is typically from the main hydraulic relief manifold assembly. The main hydraulic system oil flows through the manifold with a check valve on the outlet side. The check valve creates a constant back pressure within the manifold.

The main relief manifold assembly has two cartridges in it: the main system relief valve and a pressure reducing/relieving valve. The pressure reducing/relieving valve senses the pressure in the shift circuit and will be set to hold a specific maximum pressure. The shift pressure flows to a manual hydraulic directional valve or an electric hydraulic directional solenoid valve. When either valve is actuated, shift pressure will be sent through hoses and a ½" sliding tube mounted along with the digger drive sliding tubes assembly. At the end of the ½" sliding tube, a hydraulic hose connects the sliding tube to the actuator on the digger drive to change the speed of the digger drive. The pressure reducing valve is designed to hold a constant column of hydraulic oil and pressure in the lines and sliding tubes to the actuator with in the digger drive while operating at high speed.

Another function of the pressure reducing/relieving valve occurs when the second stage is retracted with the digger drive is lowered. When the second stage is retracted, the ½" sliding tube full of hydraulic oil starts to become compressed. As the pressure increases, the pressure reducing/relieving valve allows oil to return to the tank while maintaining the set pressure.

Checking Hydraulic Flow

Disconnect the two hydraulic hoses from the digger drive motor. Install a calibrated flow meter which has a pressure gauge and a shut off valve to create a resistance, making sure the flow meter is in series. With the hydraulic oil at normal operating temperature and maximum engine RPM and with the shut off wide open, select and hold the digger control valve in the dig position. At this point you should be seeing 40 GPM on the flow meter.

Digger Drive Rated Torque

All digger drives are design to develop a certain output torque (ft-lb) rating. For example, single-speed model # Mark I is rated at a maximum torque of 5500 ft-lbs at the correct pressure setting. A two-speed digger drive has two speeds and two torque ratings. For example, a popular two speed digger drive in the field is an Eskridge (Model 76BA) which is rated at 3000 ft-lbs in high speed and 12,000 ft-lbs in low speed.

Various sizes of hydraulic diggers are available from TEREX Utilities, to suit your soil and digging conditions. Selection also depends upon your digger derrick model.

Digger	Gearbox	Torque (ft-lb)	Speed (rpm)
Mark I®	Single Speed	5,500	40
Eskridge (Model 77BD)	Single Speed	6,500	36
Eskridge (Model 77BC)	Single Speed	8,000	30
Eskridge (Model 77BA)	Single Speed	12,000	19
Mark II®	Two Speed	Low - 8,700 / High - 4,600	Low - 24 / High - 46
Mark III®	Two Speed	Low - 14,000 / High - 4,700	Low - 16 / High - 48
Eskridge (Model 76BC)	Two Speed	Low - 8,000 / High - 3,300	Low - 30 / High - 72
Eskridge (Model 76BA)	Two Speed	Low - 12,000 / High - 3,000	Low - 19 / High - 80
Eskridge Hydrasync (Shift-On-The-Fly)			
Model 78-48	Two Speed	Low - 12,000 / High - 3,200	Low - 18 / High - 55
Model 75-51 - 25	Two Speed	Low - 13,800 / High - 4,300	Low - 16 / High - 42
Model 75-51 - 45	Two Speed	Low - 17,300 / High - 7,200	Low - 13 / High - 25
Model 75-51 - 53*	Two Speed	Low - 20,000 / High - 8,200	Low - 13 / High - 25

* output based upon 2,750 psi pressure rating.

APPENDIX: C

Augers and Tooling

There are a variety of augers available on the market today, with each type designed for work in specific soil conditions. Regardless of what type of auger is installed, it is very important that the auger and tooling are inspected daily for:

- Inspect coupler and fasteners
- Worn auger outside teeth
- Worn auger teeth
- Missing auger teeth
- Loose shank plate or missing mounting bolts
- Worn pilot bit
- Bent auger tube
- Bent auger fighting

The most standard auger used in our industry is an 18" dirt auger, designed to dig a hole in dirt with light rock conditions. When digging in other conditions, the auger tooling should be changed to the appropriate type for the terrain.

The outer tooth of the auger extends out further than the shank plate and auger fighting. This keeps the shank plate from wearing down and also increases the size of the hole to prevent the auger from binding when the auger is deep into the ground. Using the correct auger and tooling for the job will help maintain the performance of the digger drive.

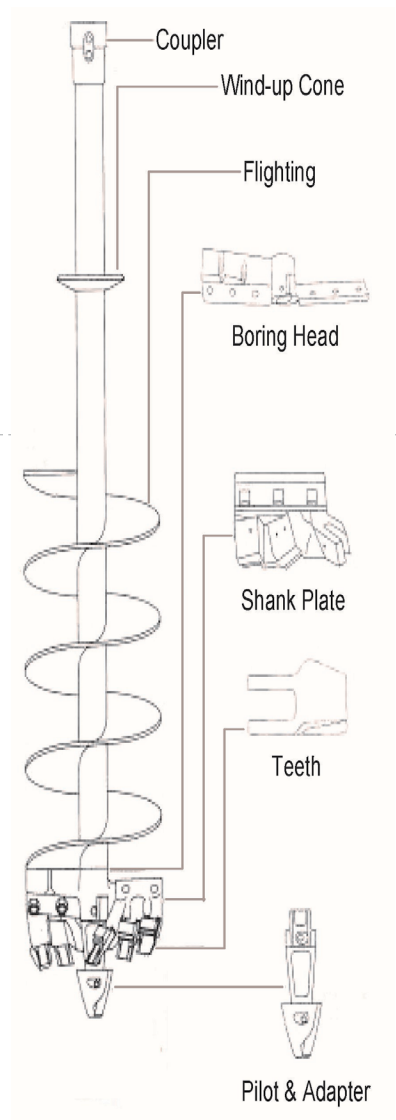



FOR FURTHER ASSISTANCE,
CONTACT THE TEREX UTILITIES TECHNICAL SUPPORT TEAM
PHONE: [1-844-TEREX4U \(1-844-837-3948\)](tel:1-844-TEREX4U) | EMAIL: UTILITIES.SERVICE@TEREX.COM
