

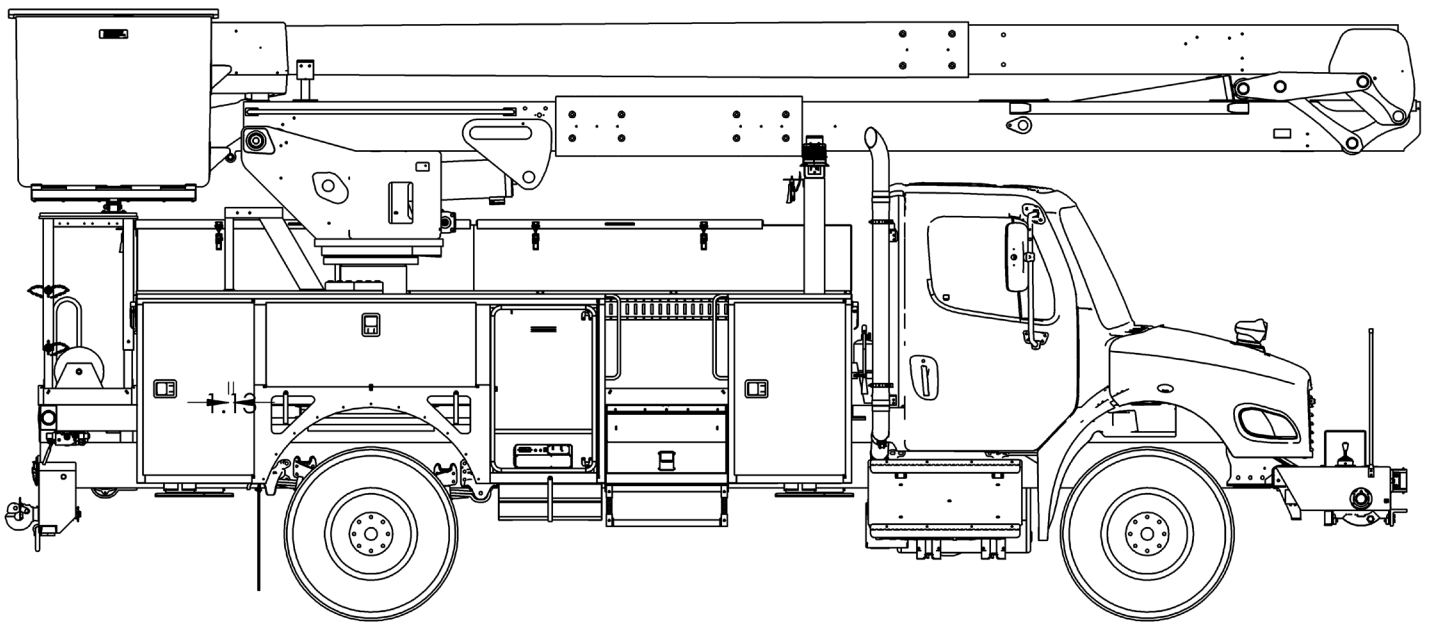

TECH TIPS

SETTING UP AN AERIAL DEVICE ON A SLOPE

NO. 14



SERVICE CALL:
SETTING UP AN AERIAL DEVICE
ON A SLOPE



MODEL(S):
ALL TEREX UTILITIES AERIAL
DEVICES



TOOLS NEEDED:
NONE

TEREX UTILITIES TECHNICAL SUPPORT TEAM

PHONE: 1-844-TEREX4U (1-844-837-3948) | EMAIL: UTILITIES.TECHSUPPORT@TEREX.COM



DANGER

Failure to obey the instructions and safety rules in the appropriate Operator's Manual and Service Manual for your machine will result in death or serious injury.

Many of the hazards identified in the Operator's Manual are also safety hazards when maintenance and repair procedures are performed.

DO NOT PERFORM MAINTENANCE UNLESS:

- ✓ You are trained and qualified to perform maintenance on this machine.
- ✓ You read, understand and obey:
 - manufacturer's instructions and safety rules
 - employer's safety rules and worksite regulations
 - applicable governmental regulations
- ✓ You have the appropriate tools, lifting equipment and a suitable workshop.

The information contained in this Tech Tip is a supplement to the Service Manual. Consult the appropriate Service Manual of your machine for safety rules and hazards.



TECH TIP 14 | RELEASED 04.13.2026 | VERSION 1.1
©TEREX UTILITIES. ALL RIGHTS RESERVED

CONTENTS

TECH TIP #14

TOC

4 ALL AERIAL DEVICES
UNITS OPERATED AT 0 DEGREE SLOPE

5 UNITS OPERATED AT 5 DEGREE SLOPE

6 UNITS OPERATED AT 20 DEGREE SLOPE

ALL AERIAL DEVICES

For any of the aerials, if the ground slope is more than 5 degrees, the tires must be cribbed or blocked until the chassis is at 5 degrees or less before setting the outriggers. We do not build any aerial devices that require the tires to be off the ground for operation.



Working on slopes that exceed 5 degrees may result in vehicle tipping over. The level indicators are only an operator aid, it will tell if the angle is over 5 degrees at the indicator location but will not tell if the ground is less than 5 degrees or frame twisted. The operator must visually verify the ground condition.

UNITS OPERATED AT A 0° SLOPE

There are specific aerials and configurations that are required to have the chassis level (0-degrees) for unit operation. These aerials are the TM model, Transmission TL (TL80, TL100, & TL80/112), and units with hydraulic lifts of 13 feet and larger.

The operator's manual or supplemental lift manual for these machines and decals on the machines state that the unit must be level for operation.



UNITS OPERATED AT A 5° SLOPE

All Terex aerial devices are tested and approved for working on slopes up to 5 degrees unless specified in the unit specific manual and indicated by the level indicator and instructions near the outrigger controls.

When parked on a 5-degree slope it may result in some of the tires not being on the ground once leveled if equipped with 2 sets of outriggers. If only equipped with one set of outriggers all tires must be on the ground and supporting the load.

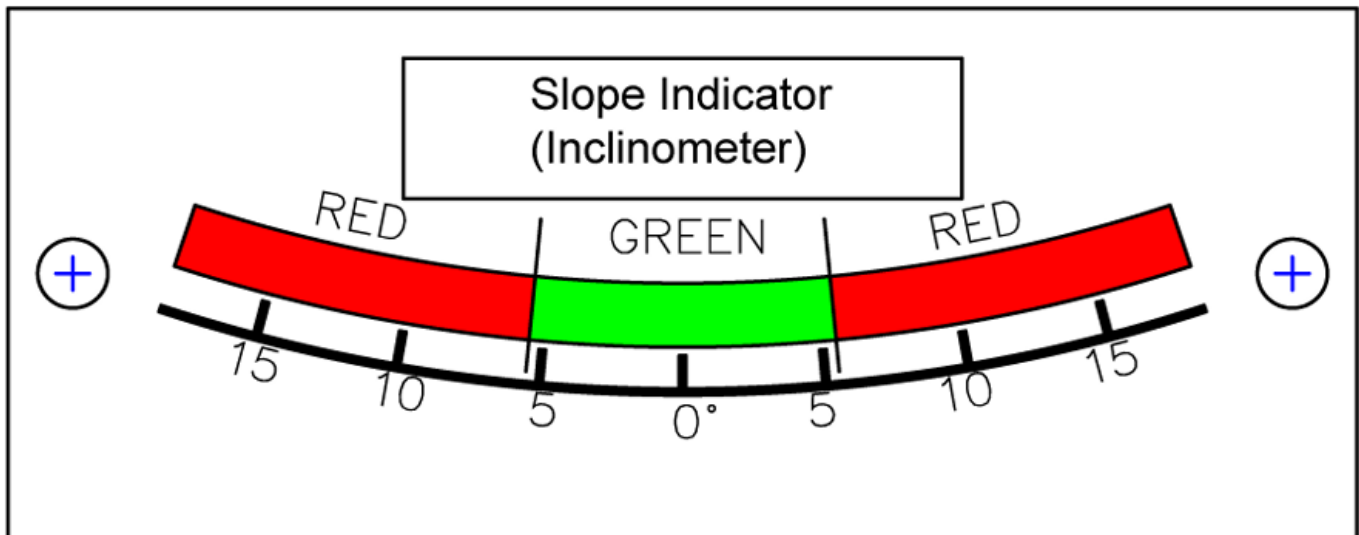

UNITS OPERATED AT A 20° SLOPE

We do have one configuration that allows operation on a 20-degree slope. It is equipped with a pedestal that tilts to get the aerial device within 5 degrees of level.

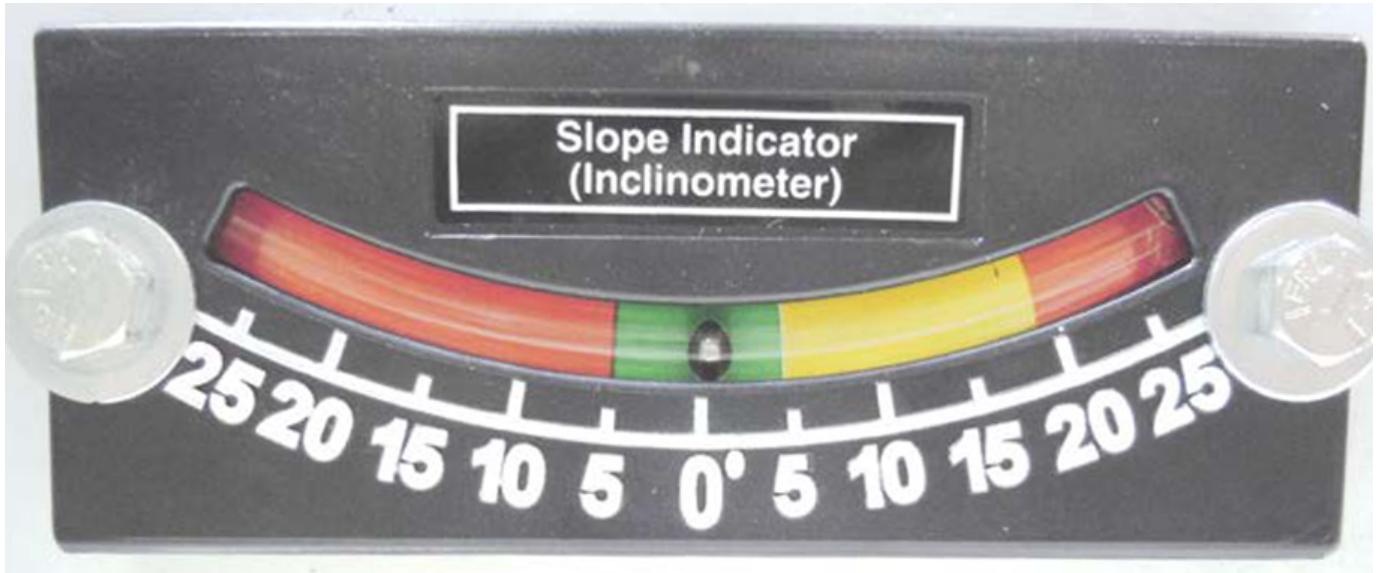

OPERATION ON SURFACES 5 TO 20 DEGREES

SETUP

- * POSITION FRONT OF TRUCK POINTING DIRECTLY DOWNHILL.
- * SET PARKING BRAKE AND PLACE CHOCKS AT ALL WHEELS.
- * RELEASE PARKING BRAKE AND ALLOW CHASSIS TO ROLL INTO CHOCKS.
- * SET PARKING BRAKE AND ENGAGE PTO.
- * ASSURE SIDE TO SIDE SLOPE IS 5 DEGREES OR LESS.
- * SET OUTRIGGERS FIRMLY BUT DO NOT REMOVE TIRE LOAD
- * FROM LOWER CONTROLS, RAISE UPPER BOOM ABOUT 2 FEET.
- * TILT TURNABLE TO LEVEL POSITION FRONT TO BACK.

STOWING

- * LOCATE BOOMS ABOUT 2 FEET ABOVE THEIR RESPECTIVE RESTS.
- * LOWER TILT TURNABLE FULLY.
- * STORE LOWER BOOM, THEN UPPER BOOM.

606769C



FOR FURTHER ASSISTANCE,
CONTACT THE TEREX UTILITIES TECHNICAL SUPPORT TEAM
PHONE: **1-844-TEREX4U (1-844-837-3948)** | EMAIL: **UTILITIES.SERVICE@TEREX.COM**
