

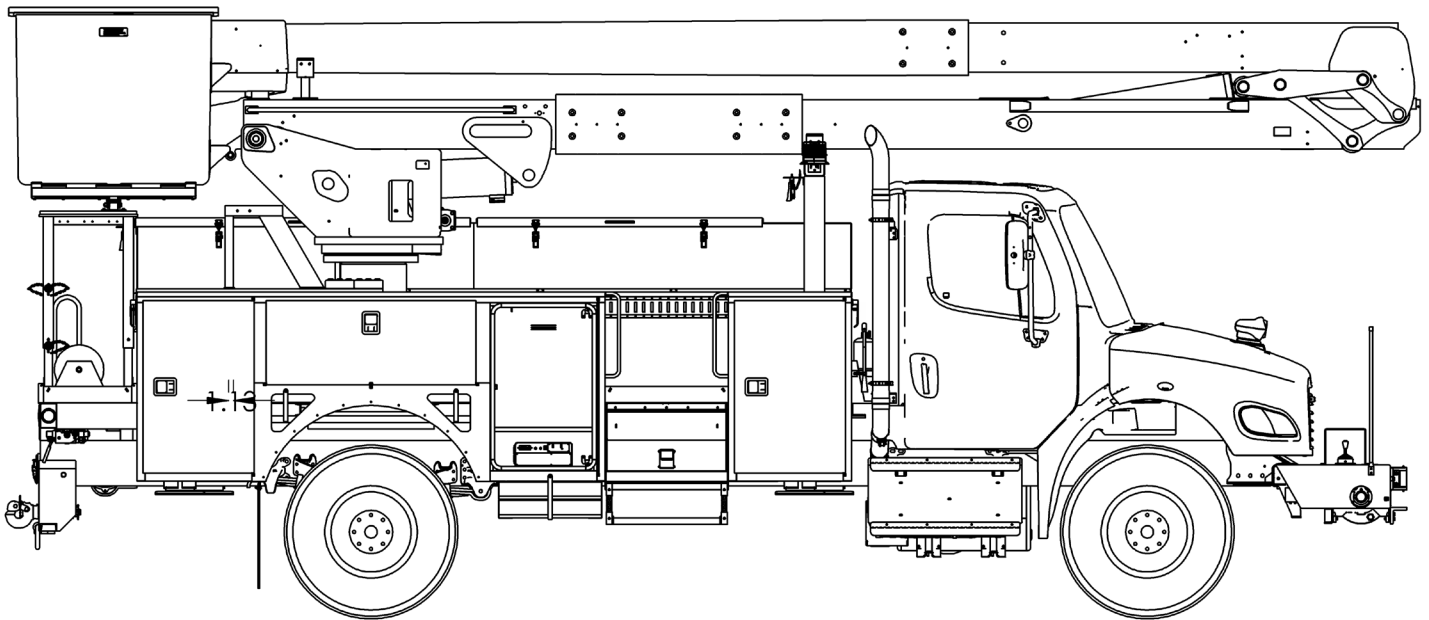

# TECH TIPS

FIBERGLASS CHART USAGE

NO. 23



**SERVICE CALL:**  
FIBERGLASS CHART USAGE



**MODEL(S):**  
ALL TEREX UTILITIES MODELS  
WITH A FIBERGLASS BOOM



**TOOLS NEEDED:**  
UNIT MAINTENANCE MANUAL  
TAPE MEASURE  
CALIPER

TEREX UTILITIES TECHNICAL SUPPORT TEAM

PHONE: 1-844-TEREX4U (1-844-837-3948) | EMAIL: [UTILITIES.TECHSUPPORT@TEREX.COM](mailto:UTILITIES.TECHSUPPORT@TEREX.COM)



## **DANGER**

Failure to obey the instructions and safety rules in the appropriate Operator's Manual and Service Manual for your machine will result in death or serious injury.

Many of the hazards identified in the Operator's Manual are also safety hazards when maintenance and repair procedures are performed.

## **DO NOT PERFORM MAINTENANCE UNLESS:**

- ✓ You are trained and qualified to perform maintenance on this machine.
- ✓ You read, understand and obey:
  - manufacturer's instructions and safety rules
  - employer's safety rules and worksite regulations
  - applicable governmental regulations
- ✓ You have the appropriate tools, lifting equipment and a suitable workshop.

The information contained in this Tech Tip is a supplement to the Service Manual. Consult the appropriate Service Manual of your machine for safety rules and hazards.



TECH TIP 23 | RELEASED 06.15.2026 | VERSION 1.1  
©TEREX UTILITIES. ALL RIGHTS RESERVED

# CONTENTS

## TECH TIP #23

### TOC

4

| Structural damage description  
| Location of damage  
| Quadrants

**INTRODUCTION**  
**STEP 1 - STEP 2**

5

| Measure the depth of cut or gouge  
| Use minor and major damage charts

**STEP 3 - STEP 4**  
**EXAMPLE**

6

**MINOR BOOM DAMAGE**

7

**CRITICAL DAMAGE**  
**QUESTIONS**

8

**MAJOR BOOM DAMAGE**

## INTRODUCTION

Structural damage can be classified according to the type of damage (cuts or bruises) that has occurred and the causes of damage (overloads).

To determine the severity of the damage, consult the Minor Damage Chart and the Major Damage Chart located in the unit specific Maintenance Manual.

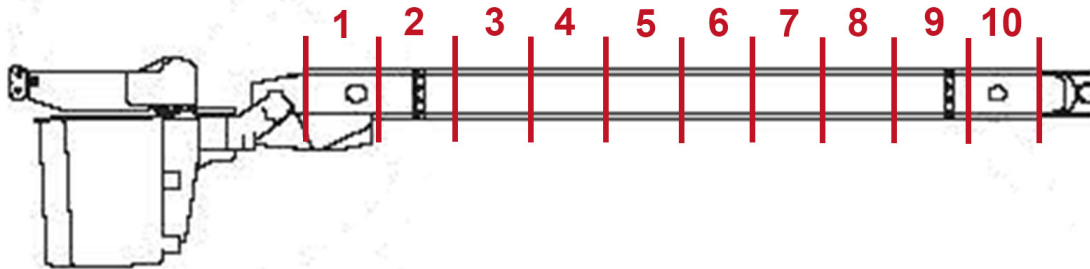

**FIGURE 1**

## STEP 1

Determine the location of the damage on the fiberglass boom.

The length of the boom is divided into 10 equal lengths. Determine which section of the boom has the damage. **FIGURE 1**

## STEP 2

The cross section of the boom is divided into 4 quadrants. There is a separate quadrant map for round booms and square or rectangular booms. Determine which quadrant the damage is located in.

**Note:** Quadrant 1 and 3 incorporate the corners of a square/rectangular boom. **FIGURE 2**

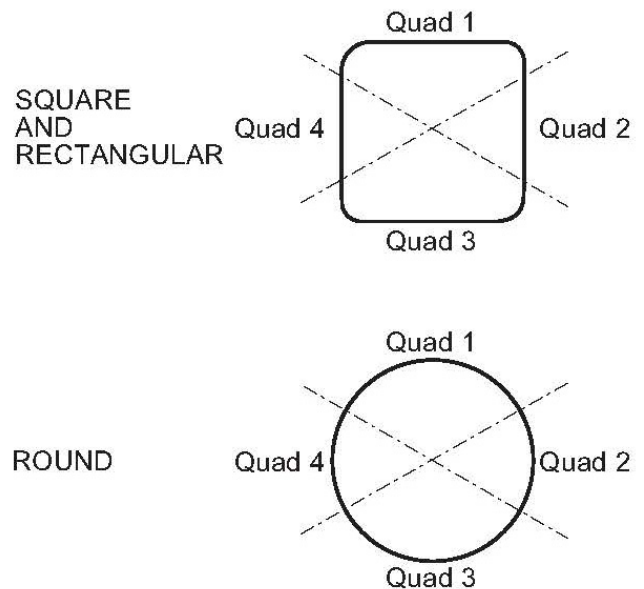

**FIGURE 2**

### STEP 3

Measure the depth of the cut or gouge, or the diameter of the bruise.

### STEP 4

Use the Minor Damage Chart and the Major Damage Chart to determine the extent of the fiberglass damage.

---

### EXAMPLE

A fiberglass boom has a cut on the top of the boom. According to the quadrant chart, the top of the boom is quadrant 1.

Measuring the damage, it is determined that the depth of the cut is 15% of the thickness of the boom. This measurement does not include the thickness of the finish which does not add to the structural strength of the boom.

Dividing the boom length into 10 equal parts, the damage is determined to be in section 4.

To determine the extent of the damage, draw intersecting lines from 15% and segment 4 on the Minor Boom Damage Chart on the next page. **FIGURE 3**

# LIMITS OF MINOR BOOM DAMAGE

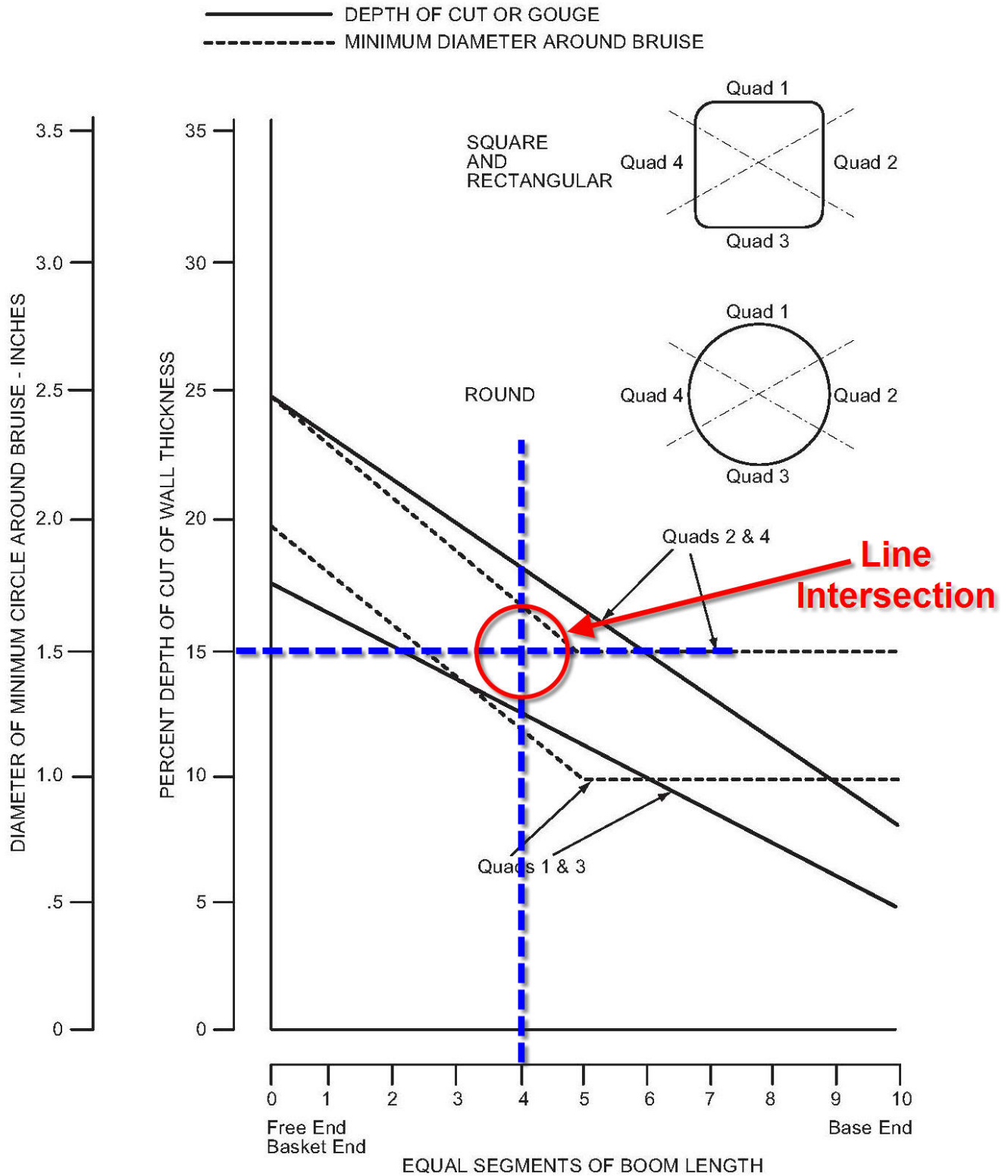

**FIGURE 3**

Note: Bruises are evaluated by removing the finish and measuring the diameter of a circle that will completely cover the bruise. Use the scale for bruises to draw the intersecting lines and the dotted line to determine the extent of the damage.

To use the Major Damage Chart, again draw intersecting lines across 15% and segment 4. If the intersecting point is above the solid line (dotted line for bruising), then the boom damage is critical. If the intersecting line is below the solid line, the damage is Major.

In this example, the damage is Major, not Critical. The point of intersection is below the solid line shown in the illustration on the next page. **FIGURE 4**

**Note:** Major and Critical boom damage must be reported to the manufacturer for analysis.

## CRITICAL DAMAGE

Structural damage to the fiberglass boom is considered un-repairable. Specific examples include:

- Any overload damage
- Complete penetration of the wall
- Major damage within 24 inches of previously repaired Major damage

## QUESTIONS

For questions or more information on this procedure please contact the Terex Utilities Technical Support Department at: 1-844-Terex4U (1-844-837-3948) or **utilities.techsupport@terex.com**.

# LIMITS OF MAJOR BOOM DAMAGE

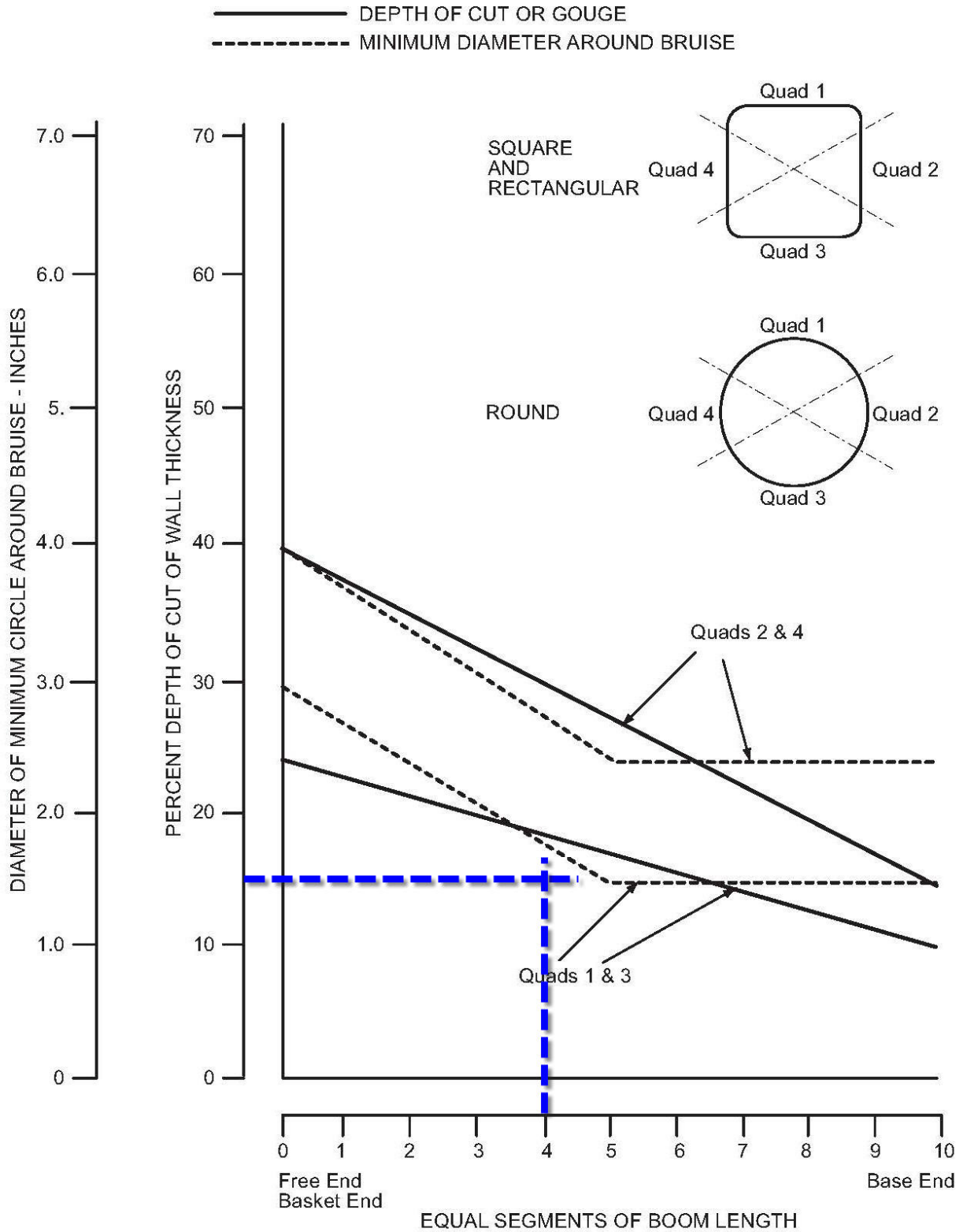

**FIGURE 4**



FOR FURTHER ASSISTANCE,  
CONTACT THE TEREX UTILITIES TECHNICAL SUPPORT TEAM  
PHONE: **1-844-TEREX4U (1-844-837-3948)** | EMAIL: **[UTILITIES.TECHSUPPORT@TEREX.COM](mailto:UTILITIES.TECHSUPPORT@TEREX.COM)**

---