

Service Call:

Bleeding the Hydraulic Leveling System

Tools Required:

S-Wrench 1/2, 9/16, 5/8, 11/16, & 3/4

Drain Pan

Model(s):

5TC, 6TC, 5FC, HRM, HR-OM, HRX, TCX,
RM, RMX, XM, & XML

Tech Tip Safety Rules





Danger

Failure to obey the instructions and safety rules in the appropriate Operator's Manual and Service Manual for your machine will result in death or serious injury. Many of the hazards identified in the operator's manual are also safety hazards when maintenance and repair procedures are performed.

Do Not Perform Maintenance Unless:

- You are trained and qualified to perform maintenance on this machine.
- You read, understand and obey:
 - manufacturer's instructions and safety rules
 - employer's safety rules and worksite regulations
 - applicable governmental regulations
- You have the appropriate tools, lifting equipment and a suitable workshop.

The information contained in this tech tip is a supplement to the service manual. Consult the appropriate service manual of your machine for safety rules and hazards.

 WARNING	
	
<p>Escaping fluid under pressure can penetrate skin causing serious injury.</p> <p>Relieve pressure before disconnecting hydraulic lines. Keep away from leaks and pin holes. Use a piece of cardboard or paper to search for leaks. Do not use your hand.</p> <p>Fluid injected into skin must be surgically removed within a few hours by a doctor familiar with this type injury or gangrene will result.</p> <p>H23877B</p>	

Step 1

Locate the boom in a suitable position to access the slave cylinder at the elbow. Raise the upper boom to provide clearance for the platform to articulate through its full range.

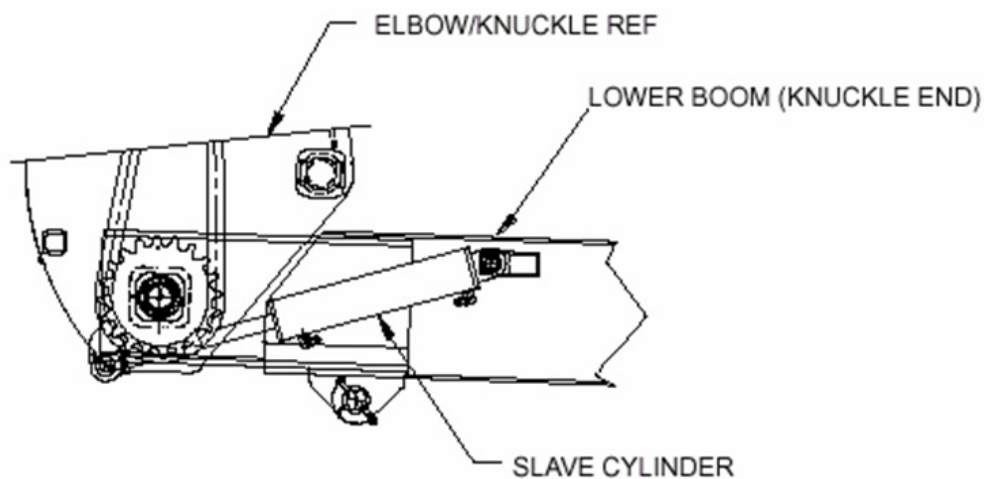

Figure 1

Step 2

Place a suitable container in a position to collect purged oil under the access hole on the elbow end of the lower boom.

Step 3

Un-pin the master cylinder rod end leaving the hydraulic hoses connected. Support the cylinder so that it can extend and retract without being damaged.

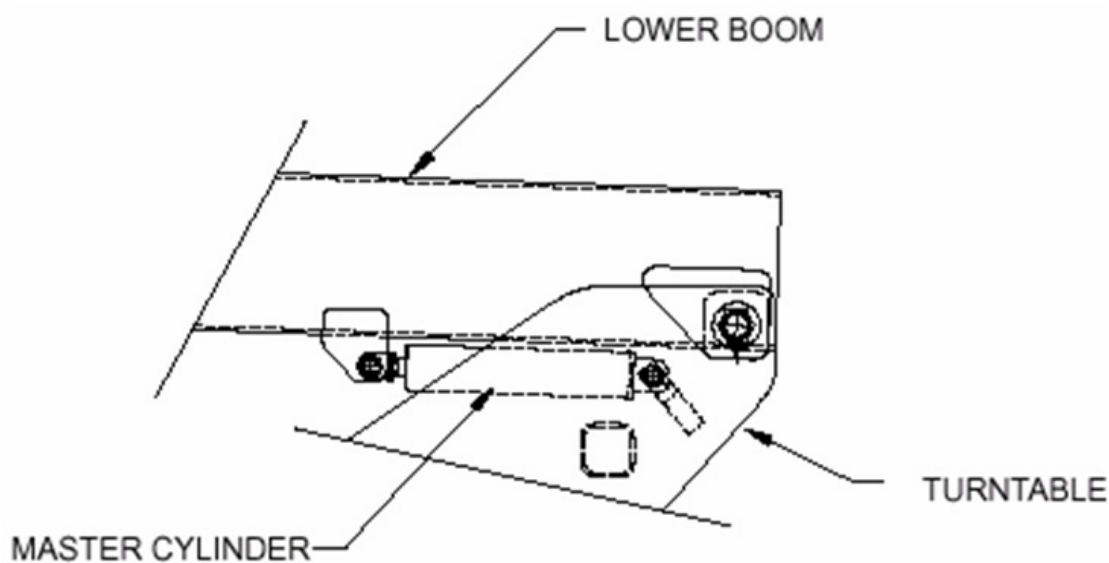

Figure 2

Step 4

Position the upper boom so the platform can rotate when the platform leveling control valve is actuated.

Step 5

Loosen fittings at location #2 (slave cylinder rod end) and location #4 (master cylinder rod end).

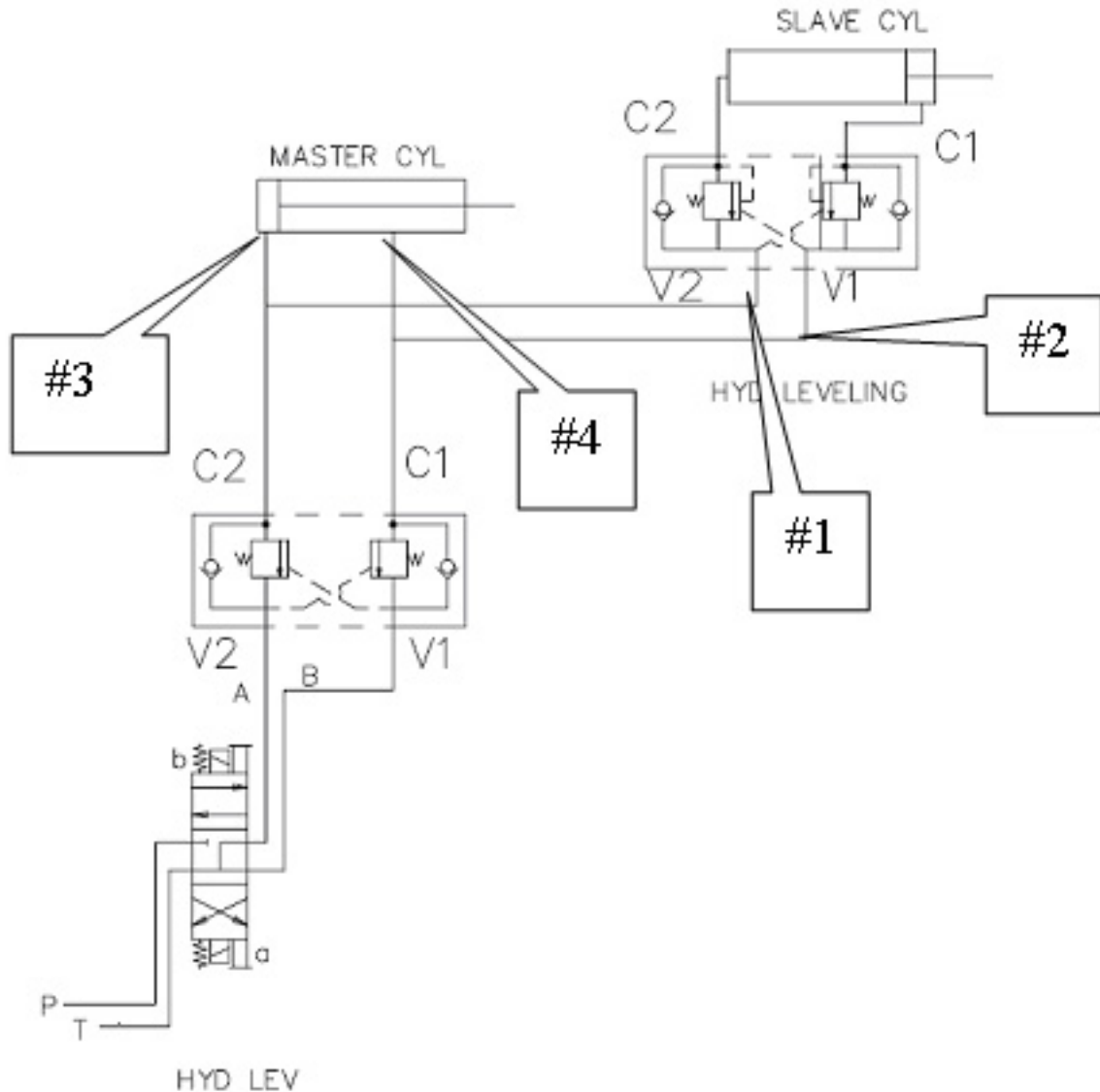

Figure 3

Tip: You can add tee fittings and 3 ft. hoses (With one end plugged) to each of the above noted locations to reduce the amount of oil in the boom and for ease of bleeding. Optional)



Escaping fluid under pressure can penetrate skin causing serious injury

Step 6

Slowly operate the leveling at the lower control causing the slave cylinder to retract (Bucket will rotate) and hold the control until the fluid coming from the two loose fittings is free of air. Tighten fittings and release the control handle.

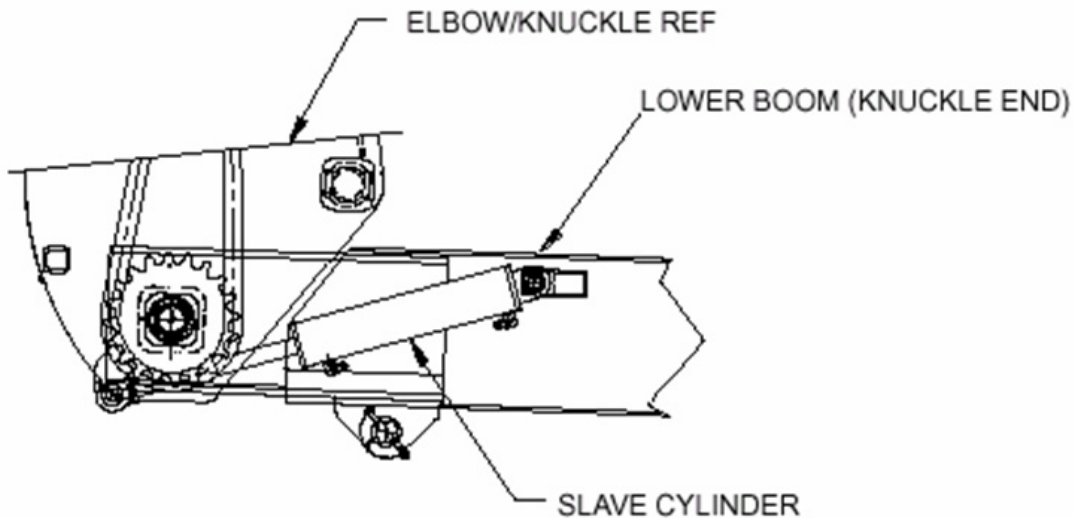

Figure 4



Escaping fluid under pressure can penetrate skin causing serious injury

Step 7

Loosen fittings at location #1 (slave cylinder base end) and location #3 (master cylinder base end). (See Figure 3 above.)



Escaping fluid under pressure can penetrate skin causing serious injury

Step 8

Slowly operate the leveling at the lower control causing the master and slave cylinder to extend (Bucket will rotate) and hold the control until the fluid coming from the two loose fittings is free of air. Tighten fittings and release the control handle.



Escaping fluid under pressure can penetrate skin causing serious injury

Step 9

Re-pin the master cylinder. Test by running the lower boom through five full cycles with basket capacity in the platform.

Step 10

Ensure that the master cylinder rod end pin retainer is properly seated.