

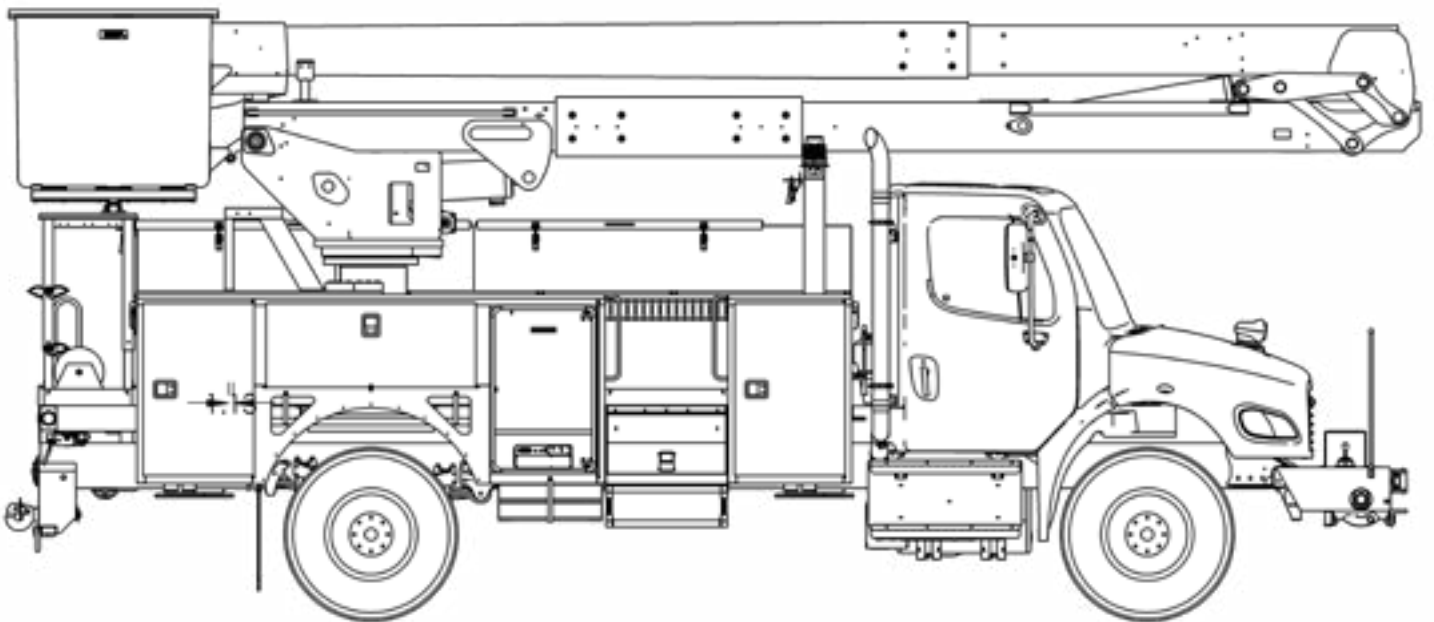

TECH TIPS

ADJUSTABLE HYDRAULIC VALVES

NO. 38



SERVICE CALL:
ADJUSTABLE HYDRAULIC VALVES



MODEL(S):
ALL TEREX UTILITIES EQUIPMENT



TOOLS NEEDED:
FLOW METER
PRESSURE GAUGE
HOLDING VALVE TEST BLOCK
WRENCHES
PORTA-POWER
HYDRAULIC FITTINGS

TEREX UTILITIES TECHNICAL SUPPORT TEAM

PHONE: 1-844-TEREX4U (1-844-837-3948) | EMAIL: UTILITIES.SERVICE@TEREX.COM



DANGER

Failure to obey the instructions and safety rules in the appropriate Operator's Manual and Service Manual for your machine will result in death or serious injury.

Many of the hazards identified in the Operator's Manual are also safety hazards when maintenance and repair procedures are performed.

DO NOT PERFORM MAINTENANCE UNLESS:

- ✓ You are trained and qualified to perform maintenance on this machine.
- ✓ You read, understand and obey:
 - manufacturer's instructions and safety rules
 - employer's safety rules and worksite regulations
 - applicable governmental regulations
- ✓ You have the appropriate tools, lifting equipment and a suitable workshop.

The information contained in this Tech Tip is a supplement to the Service Manual. Consult the appropriate Service Manual of your machine for safety rules and hazards.



TECH TIP 38 | RELEASED 03.22.2022 | VERSION 1.0
©TEREX UTILITIES. ALL RIGHTS RESERVED

CONTENTS

TECH TIP#38

TOC

4

TEMPERATURE
SYSTEM RATED FLOW
OIL FLOW REQUIREMENTS
LOW FLOW
MEASUREABLE FLOW

5

SETTING ADJUSTABLE RELIEF VALVES

6

ADJUSTABLE FLOW CONTROL VALVES

7

ADJUSTABLE PRESSURE REDUCING VALVES

8

ADJUSTABLE SEQUENCE VALVES

9

ADJUSTABLE HOLDING VALVES

VIDEO TECH-TIP

A **video tech-tip** is available as a reference to this written procedure.

TEMPERATURE

Always set all pressure control valves, flow control valves, holding valves, and logic valves at operating oil temperature, in a range between 100 to 140 degrees.

OIL FLOW REQUIREMENTS

To properly set a pressure control valve, in most cases the flow must match the system flow it is expected to control.

SYSTEM RATED FLOW

- Relief valves
- Sequencing valves
- Flow control valves

LOW FLOW

- Holding valves

MEASUREABLE FLOW (LOW OR HIGH FLOW)

- Pressure reducing valves

SETTING ADJUSTABLE RELIEF VALVES:

With the relief valve in the system – Tee a pressure gauge into the inlet of the relief valve. Verify that the system oil temperature is at operating temperature. The bypass port on the relief valve must always be connected to the low pressure (return) side of the system.

During the adjustment, verify rated flow by installing a flow meter into the hydraulic system. Operate a function to stall out an actuator, putting the relief valve that is being adjusted into bypass. Adjust the relief to the specified value, lock down the adjustment and repeat this procedure to verify that the adjustment is still correct.

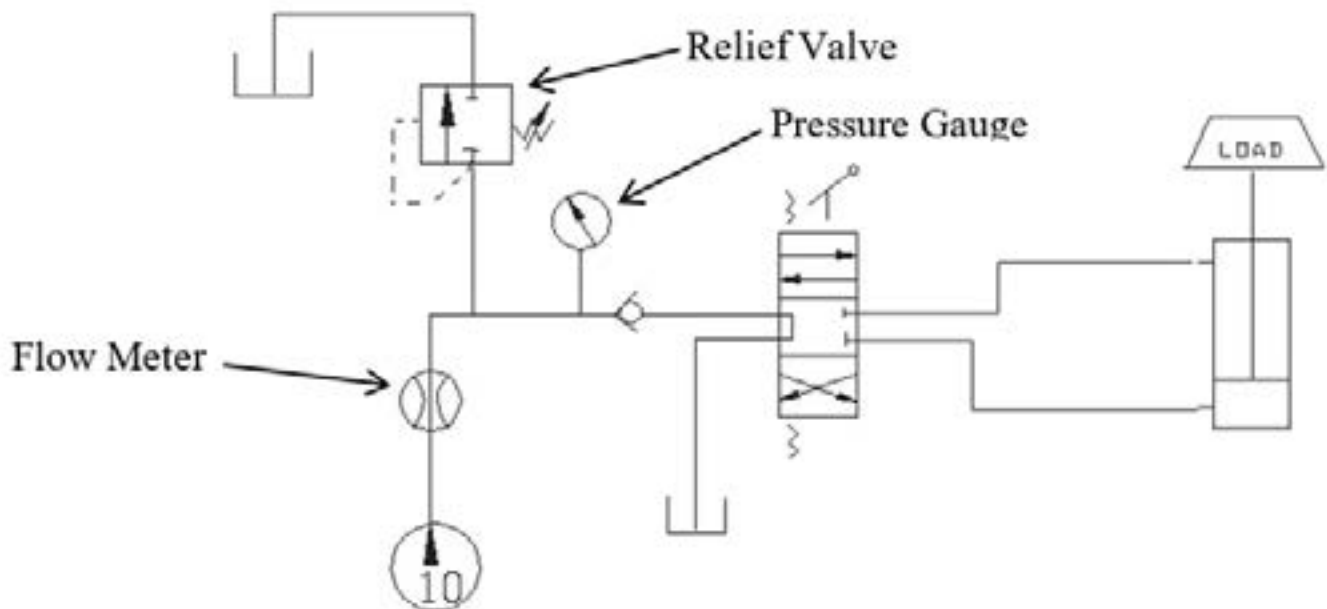

Escaping fluid under pressure can penetrate skin causing serious injury.

Relieve pressure before disconnecting hydraulic lines. Keep away from leaks and pin holes. Use a piece of cardboard or paper to search for leaks. DO NOT use your hand.

ADJUSTABLE FLOW CONTROL VALVES

Verify operating temperature, valve will be adjusted at system rated flow.

Install flow meter inline on the controlled flow port(s) on the outlet of the flow control valve. The excess port on the outlet must have a path for oil flow, blocking this port may cause failure of the valve to modulate on most flow control valves.

The controlled flow port is the circuit that the flow control valve is adjusting to the flow setting specified. Adjust the flow control valve to rated flow at the specified value for the controlled flow port. Lock down the setting and repeat test to verify that the setting is still correct.

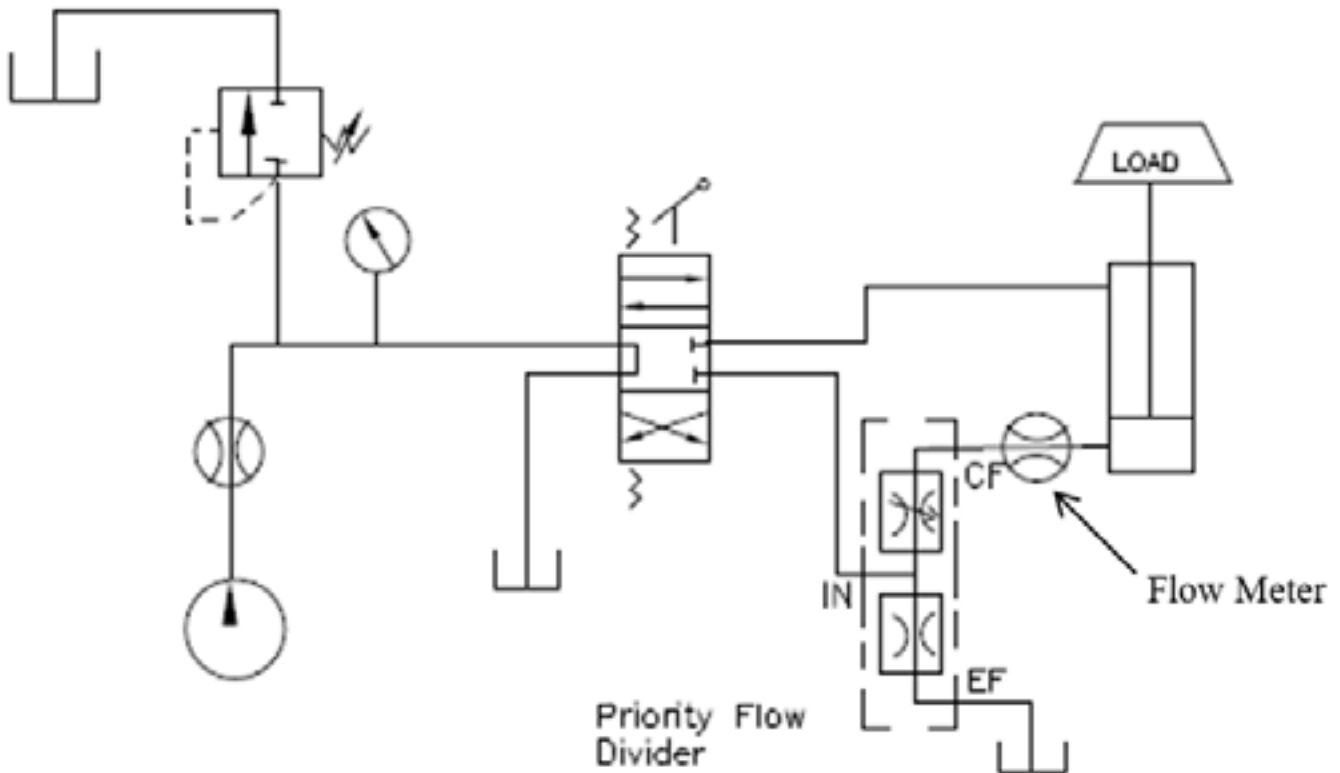

Escaping fluid under pressure can penetrate skin causing serious injury.

Relieve pressure before disconnecting hydraulic lines. Keep away from leaks and pin holes. Use a piece of cardboard or paper to search for leaks. DO NOT use your hand.

ADJUSTABLE PRESSURE REDUCING VALVES

Verify operating oil temperature. There must be oil flow through the valve to adjust up or down.

The value of the pressure reducing valve is measured by teeing a pressure gauge at the outlet. All pressure reducing valves have a drain circuit that must be connected to allow the valve to modulate.

To adjust, verify there is oil flow before adjusting valve to the specified value. The inlet pressure must be higher than the desired setting of the valve to make an adjustment. Lock down the adjustment and repeat the test to verify the setting is still correct.

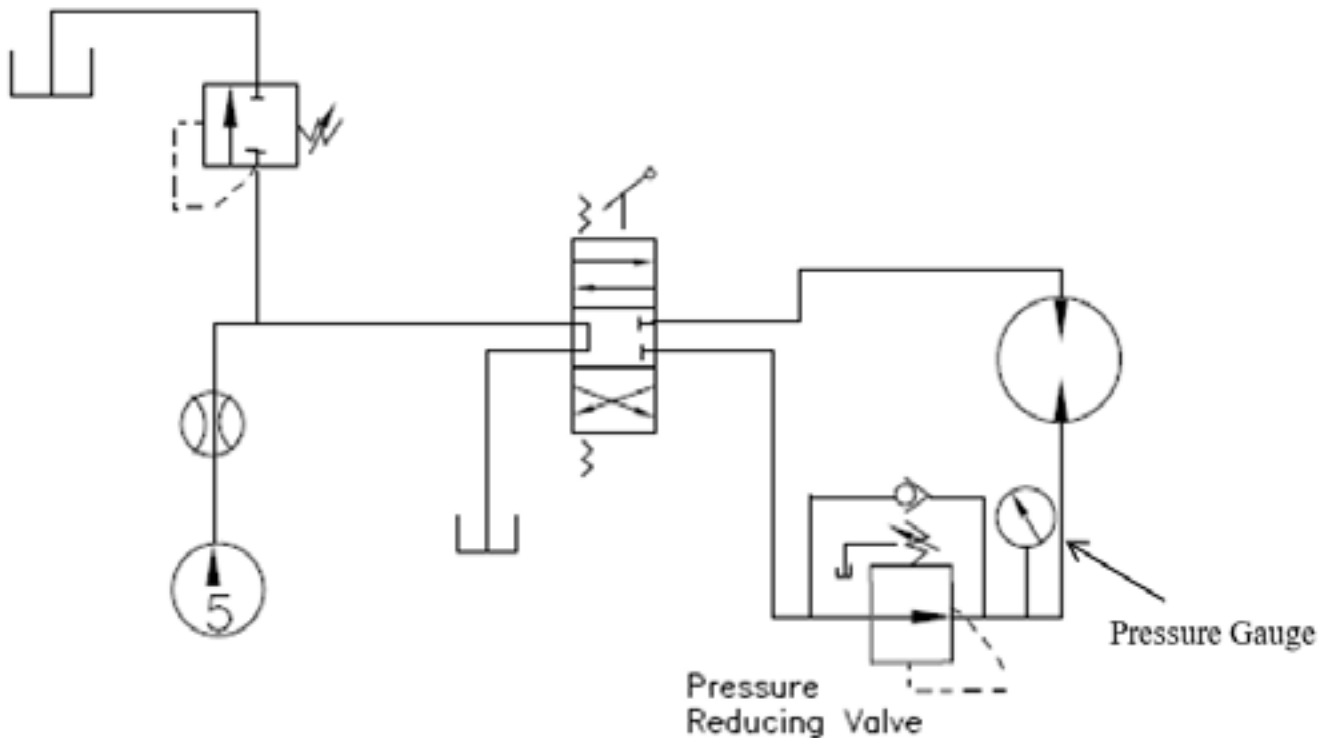

Escaping fluid under pressure can penetrate skin causing serious injury.

Relieve pressure before disconnecting hydraulic lines. Keep away from leaks and pin holes. Use a piece of cardboard or paper to search for leaks. **DO NOT** use your hand.

ADJUSTABLE SEQUENCE VALVES

Verify operating oil temperature, valve will be adjusted at system rated flow. The value of the sequence valve is measured by teeing a pressure gauge at the inlet. All sequence valves have a drain circuit that must be connected to allow the valve to modulate. Valve is a normally closed valve that opens and redirects oil at a specified pressure setting.

Tee pressure gauge at the inlet. At the rated flow of the circuit, adjust valve by creating a pressure rise in the circuit. Adjust the valve to open at the specified value directing oil to the downstream circuit. Lock down the adjustment and repeat the test to verify the setting is still correct.

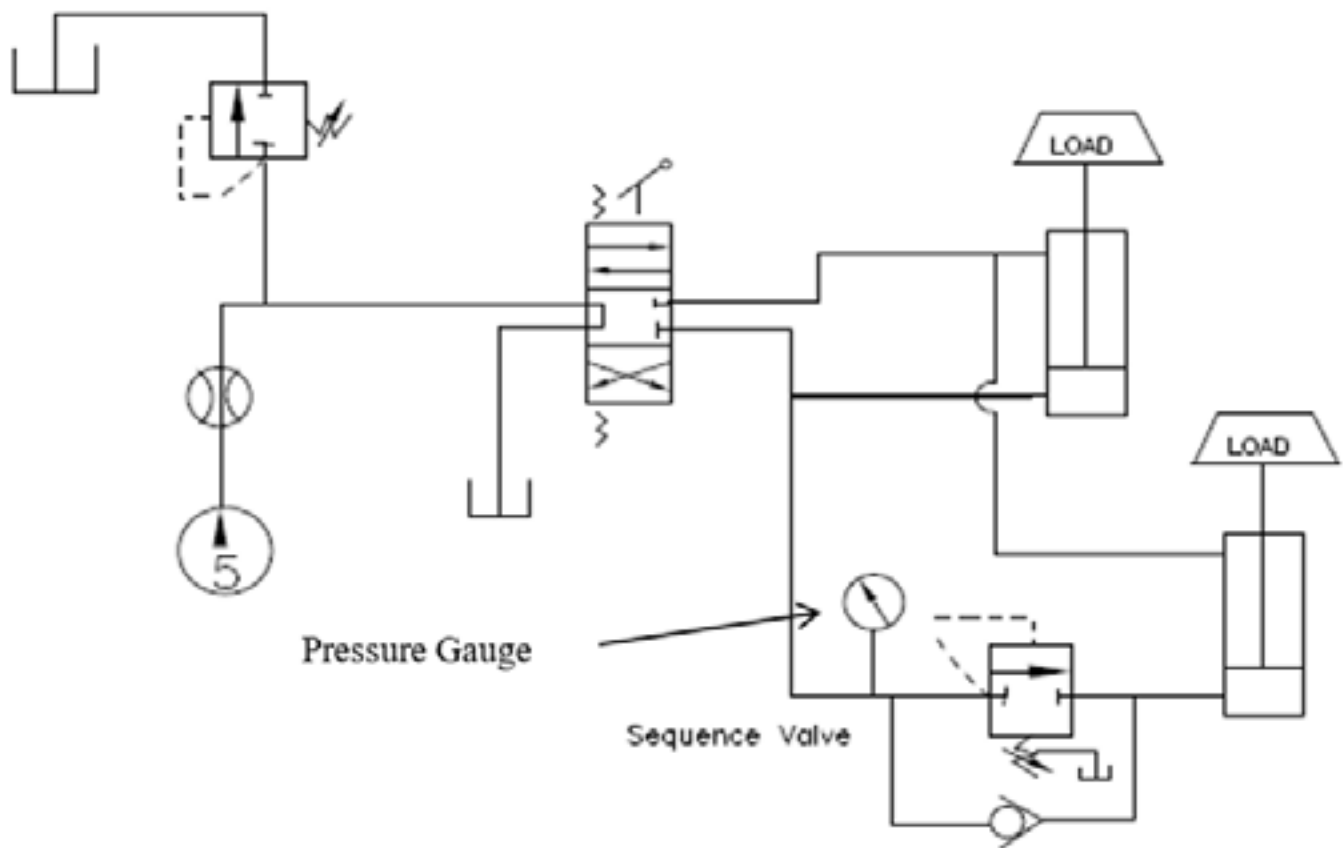

Escaping fluid under pressure can penetrate skin causing serious injury.

Relieve pressure before disconnecting hydraulic lines. Keep away from leaks and pin holes. Use a piece of cardboard or paper to search for leaks. **DO NOT** use your hand.

ADJUSTABLE HOLDING VALVES

Verify oil is at operating temperature, valve will be adjusted at low flow.

To achieve the most accurate results, adjust this setting on a test block with a hydraulic source capable of developing pressure higher than the specified value of the valve.

If removing from a machine, the assembly or component must be supported before releasing the pressure on the holding valve and hydraulic circuit.

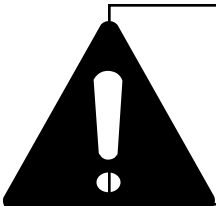

Prior to the removal of any holding valve, be certain the component or assembly is properly supported. Removing the holding valves will cause the load of the cylinder to free-fall unless supported.



Before holding valves are removed be sure to relieve as much trapped pressure inside the cylinder as possible. This will prevent damage to the holding valve seals. Always stow the booms, disengage the PTO so the hydraulic pump is not operating. Moving the valve function (retract, up, down) back and forth several times to relieve the pressure in the lines to the cylinder. Pressure may still be trapped in the cylinder. It may be necessary to Release pressure in cylinder by releasing the holding valve setting.

Install the holding valve in a test block appropriate for the holding valve. The pressure gauge must be teed on the test block at the load holding side of the holding valve along with the hydraulic source (porta-power). Increase the pressure on the load supporting port, observing when the oil leakage through the valve changes from a drip to a stream.

Adjust the holding valve to the specified value; the value when the drip changes to a very small stream. Consult the manufacturer of the holding valve to verify the direction of adjustment, not all holding valves adjust in the same direction for increasing or decreasing the pressure setting.

Verify that the holding valve will reset and maintain the value specified by the holding valve manufacturer. The valve will reset at a lower pressure than the pressure setting it opens at, this is normal and not a malfunction.

Lock down the adjustment and repeat the test to verify the setting is still correct.



Escaping fluid under pressure can penetrate skin causing serious injury.

Relieve pressure before disconnecting hydraulic lines. Keep away from leaks and pin holes. Use a piece of cardboard or paper to search for leaks. DO NOT use your hand.

The illustration below is an example of one type and brand of holding valve in a test block to verify relieving pressure setting.

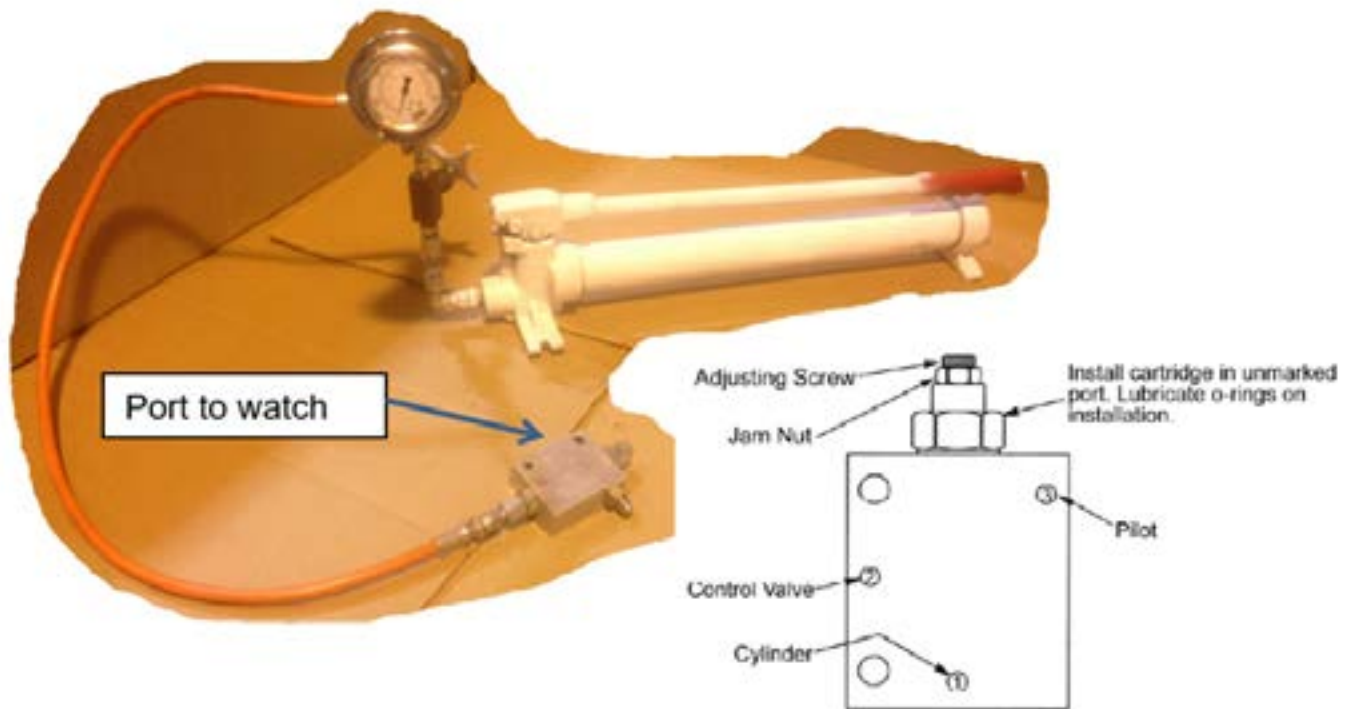

Escaping fluid under pressure can penetrate skin causing serious injury.

Relieve pressure before disconnecting hydraulic lines. Keep away from leaks and pin holes. Use a piece of cardboard or paper to search for leaks. **DO NOT** use your hand.



FOR FURTHER ASSISTANCE,
CONTACT THE TEREX UTILITIES TECHNICAL SUPPORT TEAM
PHONE: [1-844-TEREX4U \(1-844-837-3948\)](tel:1-844-TEREX4U) | EMAIL: UTILITIES.SERVICE@TEREX.COM
