

## **Service Call:**

### Rotation Bearing Deflection Test

## **Tools Required:**

- Dial Indicator with Magnetic Base
- Maintenance Manual for the Unit Being Tested

## **Model(s):**

Non Over-Center Aerial Devices:

TC, TCX, RM, RMX, TM

## **Bearing Deflection**

The following procedure can be used for all of the models listed above, regardless of the age of the unit.

## Tech Tip Safety Rules



### **Danger**

Failure to obey the instructions and safety rules in the appropriate Operator's Manual and Service Manual for your machine will result in death or serious injury. Many of the hazards identified in the operator's manual are also safety hazards when maintenance and repair procedures are performed.

### **Do Not Perform Maintenance Unless:**

- You are trained and qualified to perform maintenance on this machine.
- You read, understand and obey:
  - manufacturer's instructions and safety rules
  - employer's safety rules and worksite regulations
  - applicable governmental regulations
- You have the appropriate tools, lifting equipment and a suitable workshop.

The information contained in this tech tip is a supplement to the service manual. Consult the appropriate service manual of your machine for safety rules and hazards.

## **Step 1**

Read this entire procedure and the section in the maintenance manual that applies to this procedure before starting the work.

## **Step 2**

Position the truck in a suitable location, checking for overhead obstructions. Set the outriggers and level the machine. There can be no additional tools or materials in the platform with the exception of a platform liner.

## Step 3

### TC and TCX:

Check for obstructions before rotating boom. Rotate boom off rear of vehicle. Place lower boom at 0 degrees and upper boom at 50 degrees from horizontal. See image below.

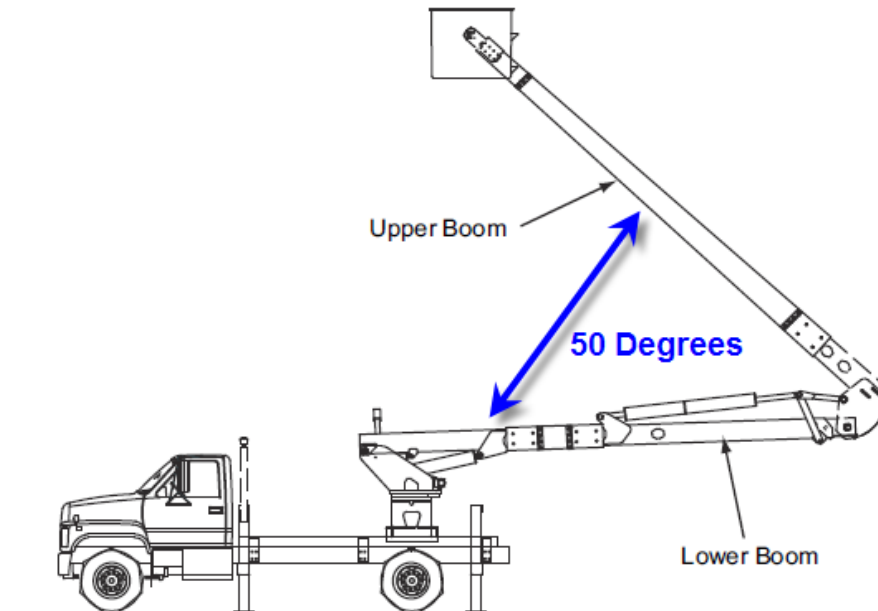

## TM Series:

Check for obstructions before rotating boom off rear of vehicle. Place lower boom just out of the lower boom rest and upper at 15 degrees. See image below

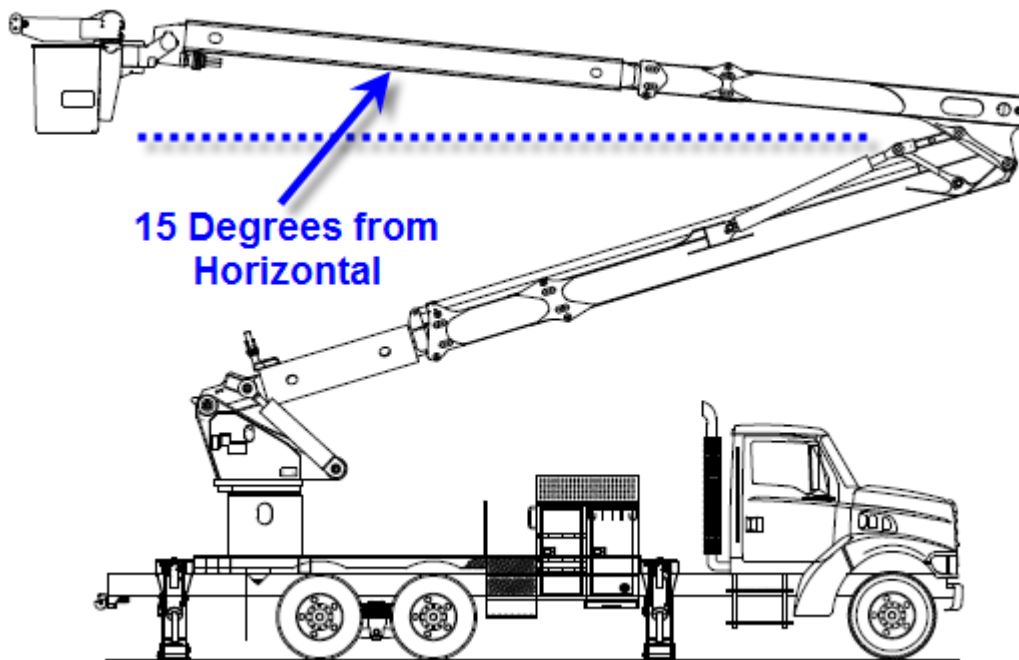

## RM and RMX:

Check for obstructions before rotating boom.  
Rotate boom off rear of vehicle. Place lower  
boom at 0 degrees and upper at 50 degrees.  
See image below.

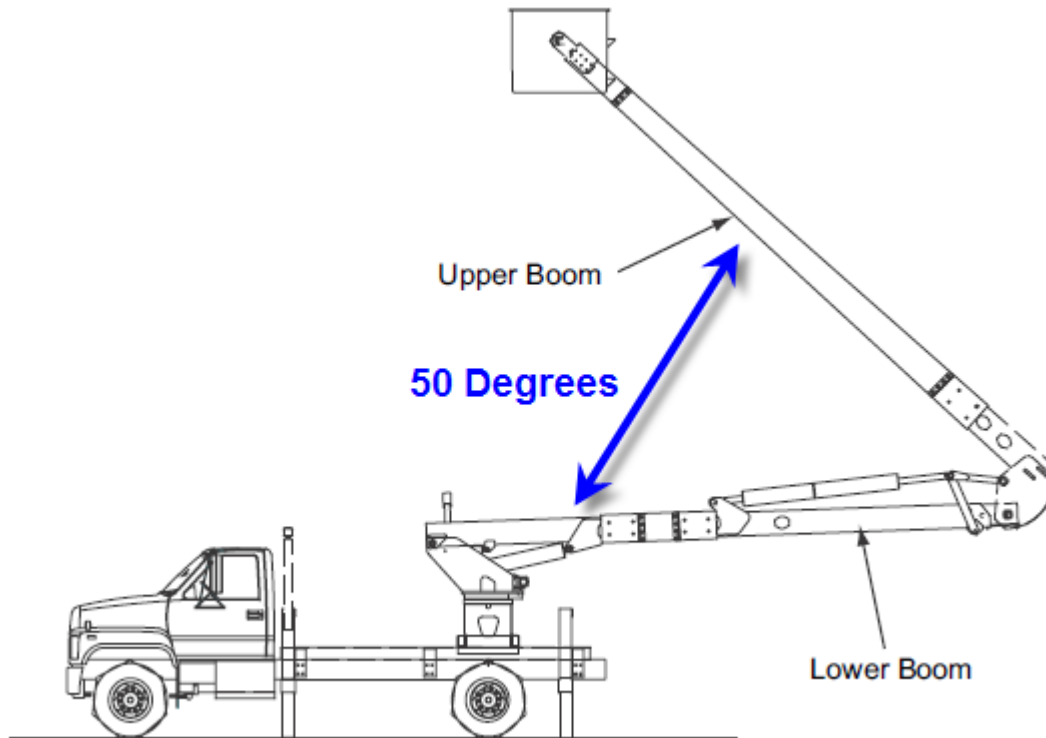

## Step 4

Attach the dial indicator base to the pedestal, positioning the tip perpendicular to the edge of the turntable bottom plate at the specified indicator radius.

**Note:** Consult the table at the end of this document for the dial indicator radius for your specific unit.

**Note:** Make sure you know which way the dial indicator rotates when it moves to get the correct reading.

## TC and TCX

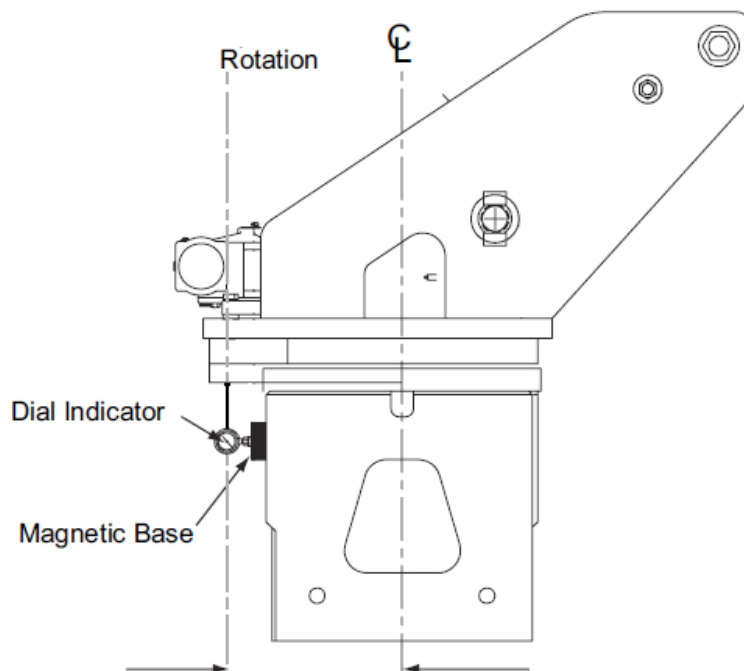

## RM and RMX:

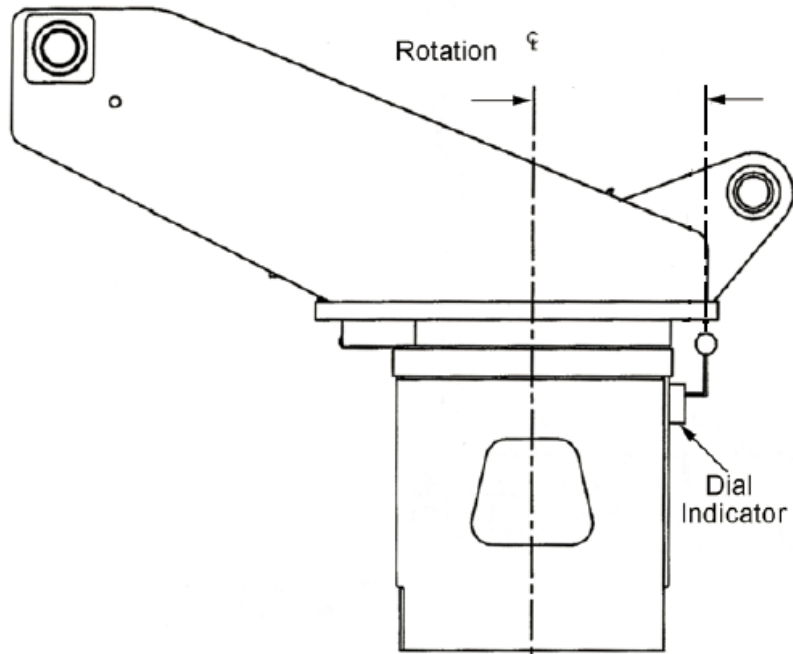

## TM Series:

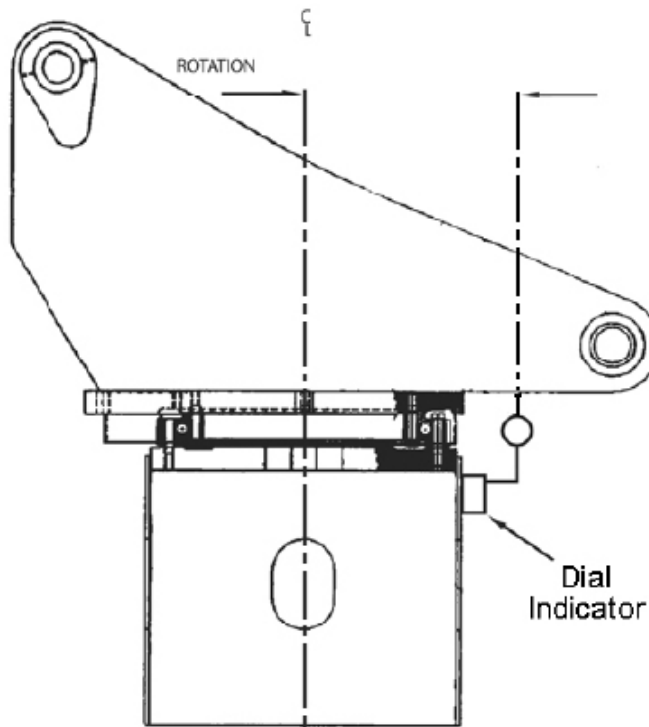



## Step 5

Zero out the dial indicator. Verify that you have at least .25 inches of movement on the dial indicator in both directions when zeroing.

## Step 6

### TC and TCX

Position the lower boom as indicated in the illustration below. Lower boom fully articulated and upper at horizontal.

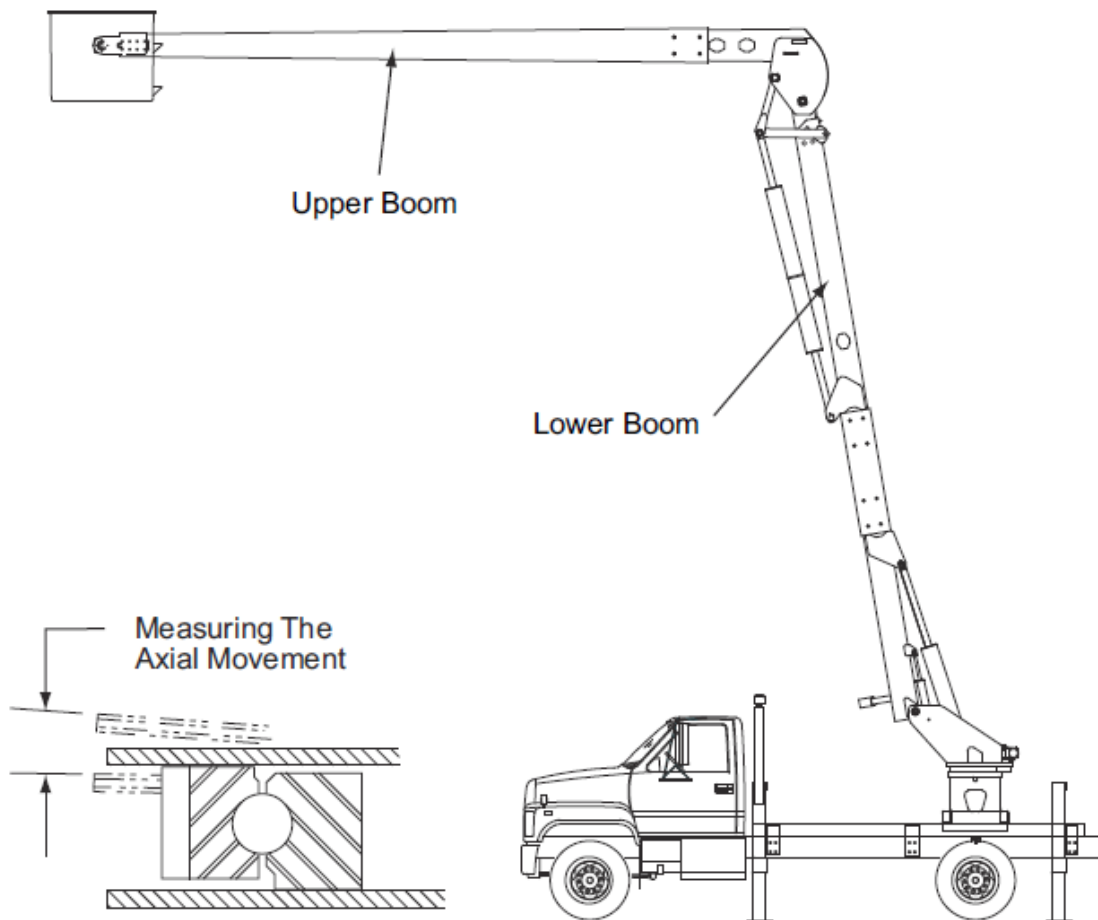

## RM and RMX: Lower boom at 90 degrees and Upper boom horizontal.

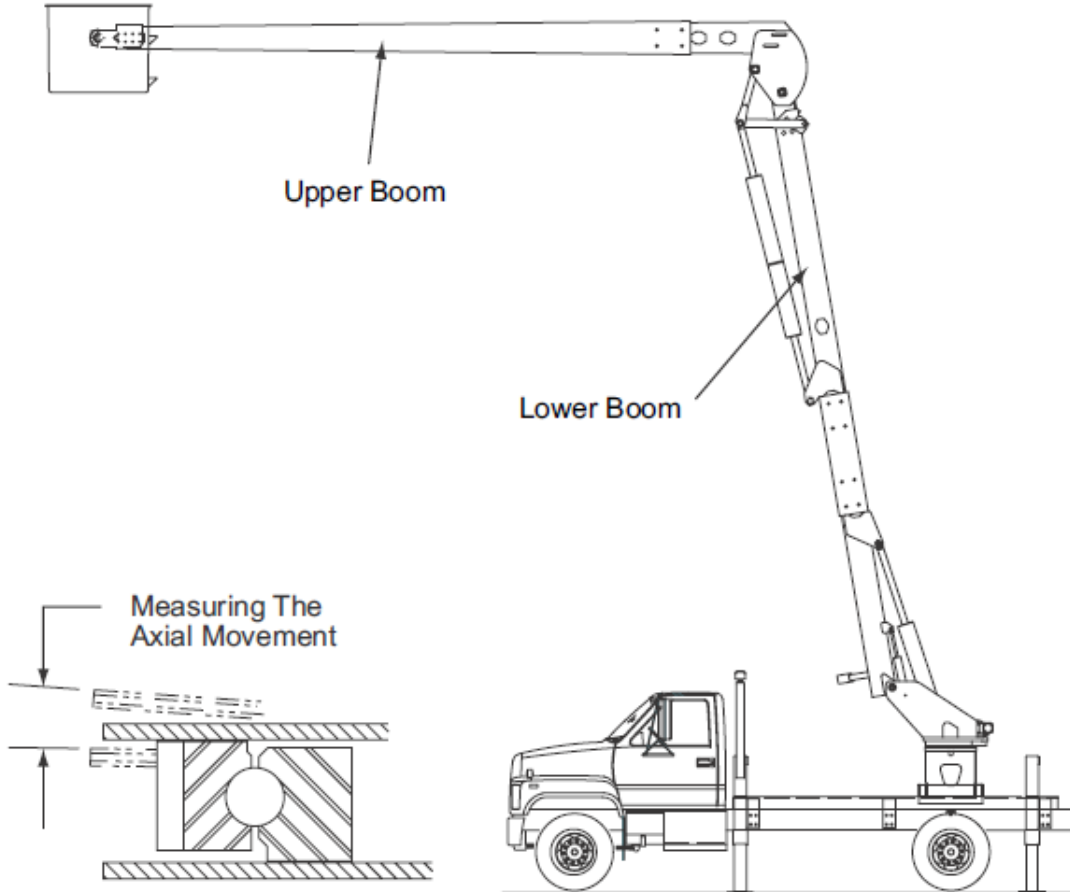

**TM Series:** Lower boom fully articulated and upper at horizontal.

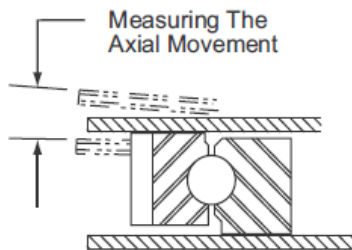
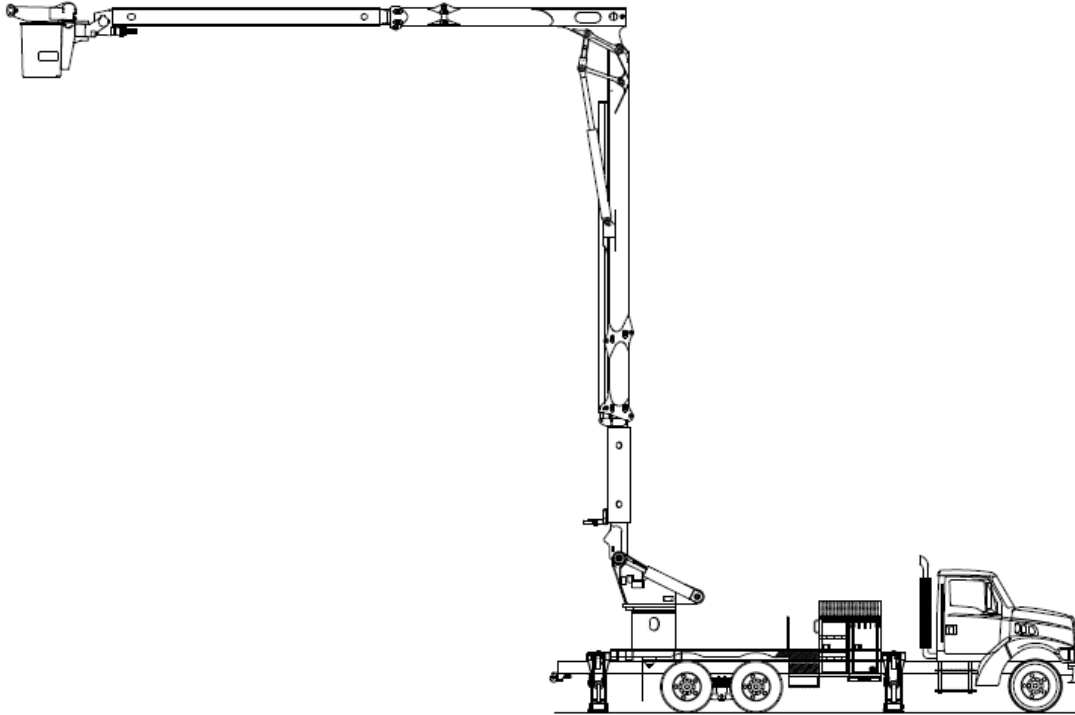

## Step 6

Read the number on the dial indicator. This is your rotation bearing deflection. Record the reading and check this reading against the “Maximum Allowable Bearing Deflection” in the following table.

**Note:** This value is based on a specific dimension of the reading from the centerline of rotation. This dimension is given with the maximum deflection.

**Note:** Measure the deflection at the same boom location and dial indicator radius every time this test is performed to provide consistent measurements that can be compared over the life of the machine.

Unit	Manual	Indicator Radius	Max Deflection
TC	463193	14.00	0.160
TCX	477476	14.00	0.160
RM	472198	15.00	0.156
RMX	483019	15.00	0.156
TM85/100	472798	17.50	0.135
TM105/125	472798	20.00	0.155

### Model Specific Maximum Allowable Bearing Deflection