

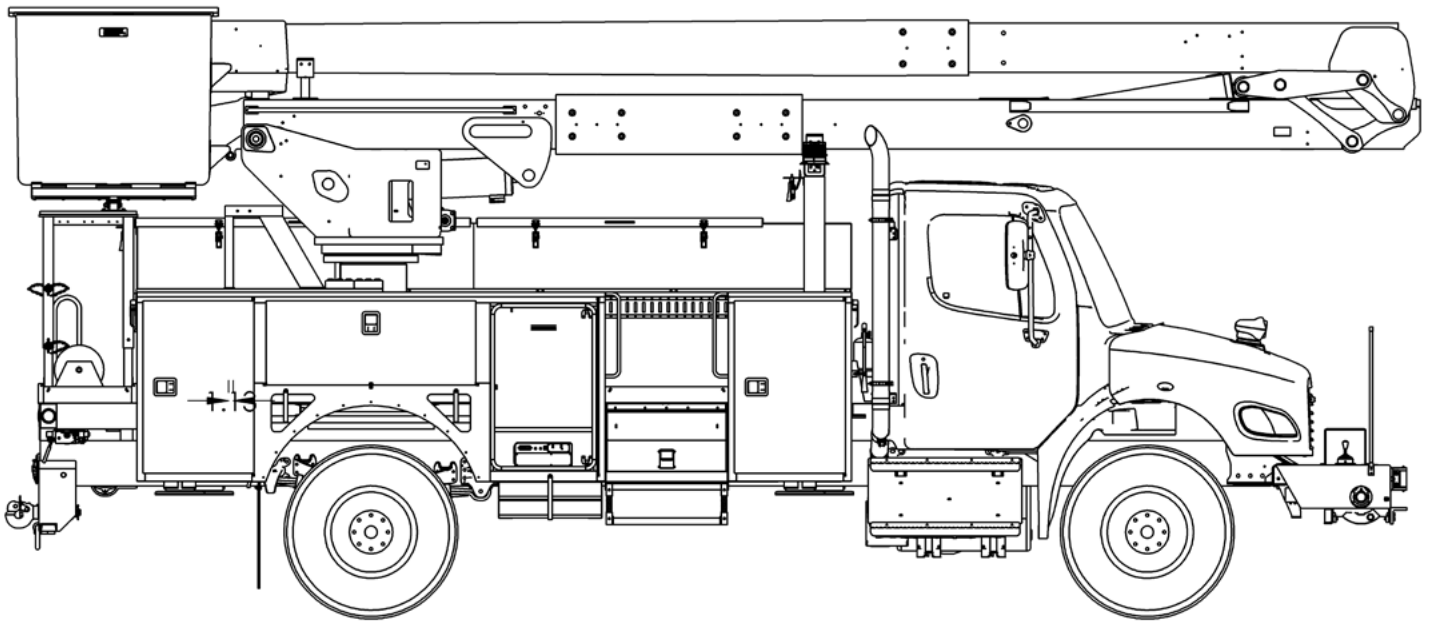

# TECH TIPS

HOW TO ADJUST TORQUE VALUES WHEN USING TORQUE ADAPTERS

NO. 53



**GENERAL KNOWLEDGE**  
HOW TO ADJUST TORQUE VALUES  
WHEN USING TORQUE ADAPTERS



**MODEL(S):**  
ALL TEREX UTILITIES EQUIPMENT



**TOOLS NEEDED:**  
CALIBRATED TORQUE WRENCH  
TAPE MEASURE  
CALCULATOR

TEREX UTILITIES TECHNICAL SUPPORT TEAM

PHONE: 1-844-TEREX4U (1-844-837-3948) | EMAIL: [UTILITIES.SERVICE@TEREX.COM](mailto:UTILITIES.SERVICE@TEREX.COM)



## **DANGER**

Failure to obey the instructions and safety rules in the appropriate Operator's Manual and Service Manual for your machine will result in death or serious injury.

Many of the hazards identified in the Operator's Manual are also safety hazards when maintenance and repair procedures are performed.

## **DO NOT PERFORM MAINTENANCE UNLESS:**

- ✓ You are trained and qualified to perform maintenance on this machine.
- ✓ You read, understand and obey:
  - manufacturer's instructions and safety rules
  - employer's safety rules and worksite regulations
  - applicable governmental regulations
- ✓ You have the appropriate tools, lifting equipment and a suitable workshop.

The information contained in this Tech Tip is a supplement to the Service Manual. Consult the appropriate Service Manual of your machine for safety rules and hazards.



TECH TIP 53 | RELEASED 07.26.2022 | VERSION 1.0  
©TEREX UTILITIES. ALL RIGHTS RESERVED

# CONTENTS

## TECH TIP#53

### TOC

5 | *Torque wrench adjustment formula*  
**STEP 1 - STEP 3**

6 **EXAMPLE A**

8 **EXAMPLE B**

10 **EXAMPLE C**

11 **EXAMPLE D**  
**EXAMPLE E**

# EXAMPLES



**CALIBRATION STICKER EXAMPLE**

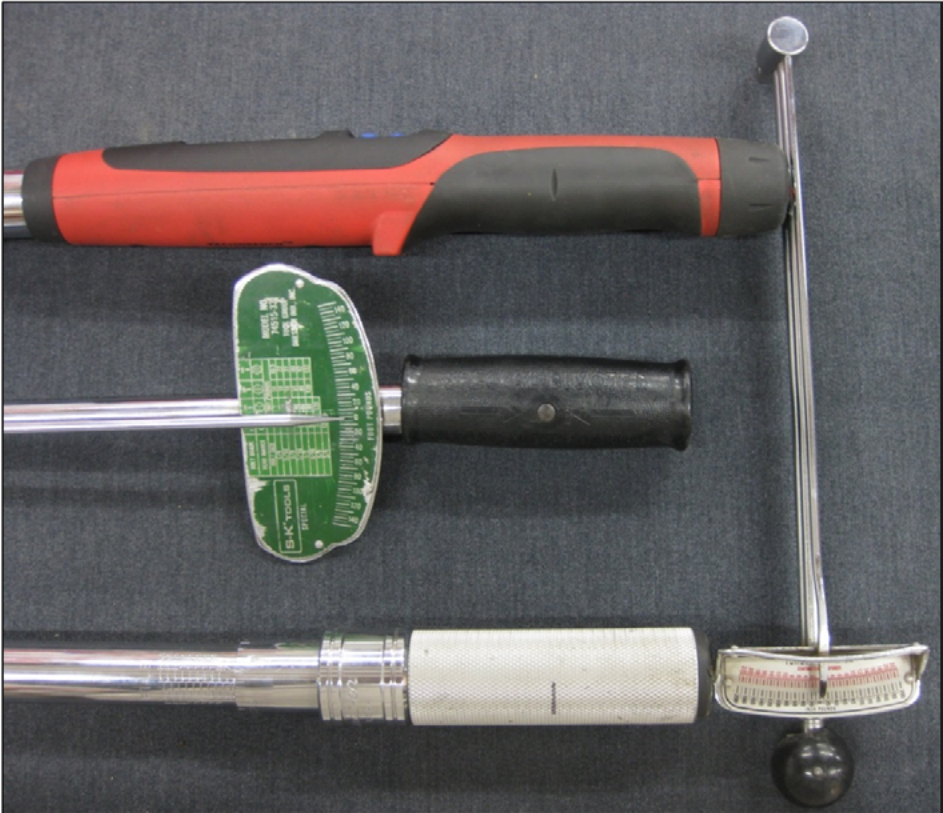

## STEP 1

Shown in **FIGURE 4** are examples of items that affect the torque applied to the fastener.

Any adapter or offset that changes the distance between the centerline of the fastener and the centerline of the torque wrench drive will require an adjustment to the setting of the torque wrench. If no adjustment is made, the fastener will not have the correct torque applied to it. A straight extension used between the adapter and the torque wrench does not affect the torque setting.



**FIGURE 4**

## STEP 2

The formula to adjust your torque wrench setting is:  
(Torque Wrench Length X Torque Desired)

Divided by:

(Torque Wrench Length + Extension Length)

## STEP 3

We will use a desired torque of 180 ft.-lbs. in the following examples.

# EXAMPLE A



## STEP 1

Determine length of torque adapter or offset of fastener to torque wrench by measuring the distance between the centers as shown below.

The length of the torque adapter in the picture is 3 inches.



## STEP 2

Measure the length of your torque wrench from the center of rotation to the center of the handle. Some wrenches have a mark on the handle for reference. If no reference mark is present on the torque wrench, mark the center of the handle area for measurement.

The length of the torque wrench pictured is 18.5 inches.

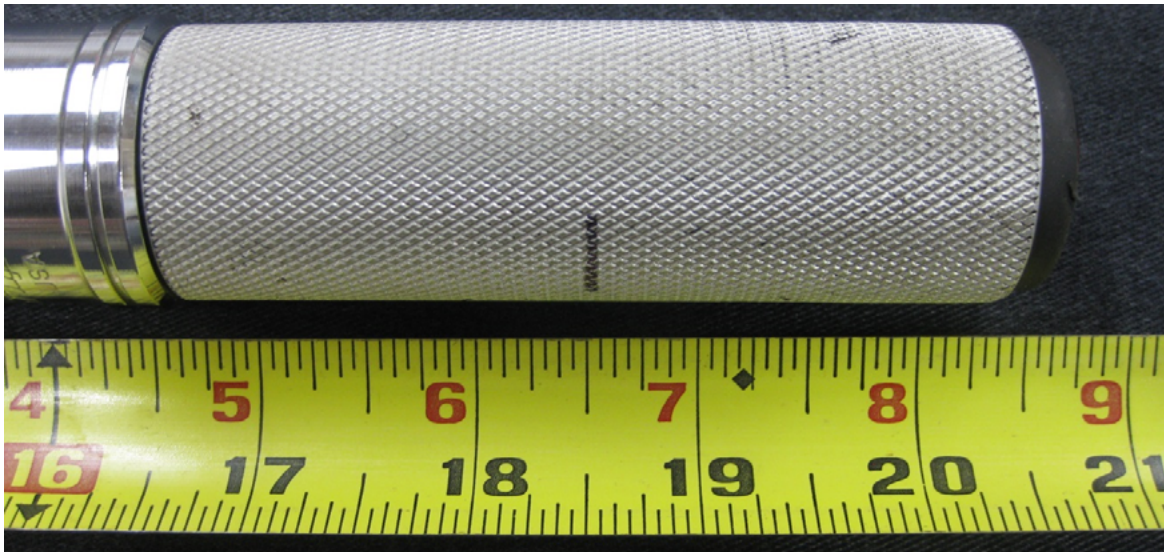
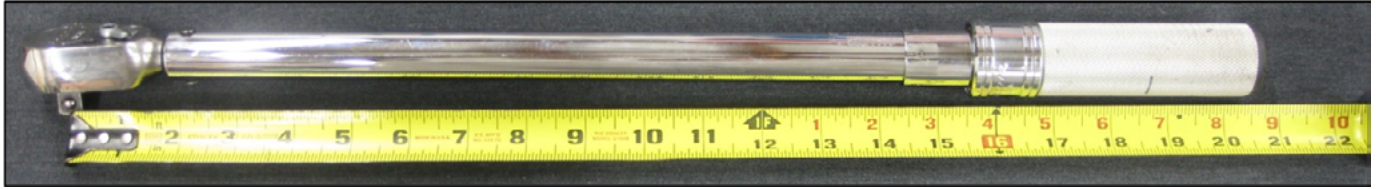

### STEP 3

(Torque Wrench Length X Torque Desired) = (18.5 x 180) = 3,330

Divided by:

(Torque Wrench Length + Extension Length) = (18.5 + 3) = 21.5 inches

$3,330 / 21.5 = 155 \text{ ft.-lbs.}$

A torque wrench setting of 155 ft.-lbs. is needed to adjust for the 3 inch torque adapter being used to get a torque value of 180 ft.-lbs.

---

### EXAMPLE B

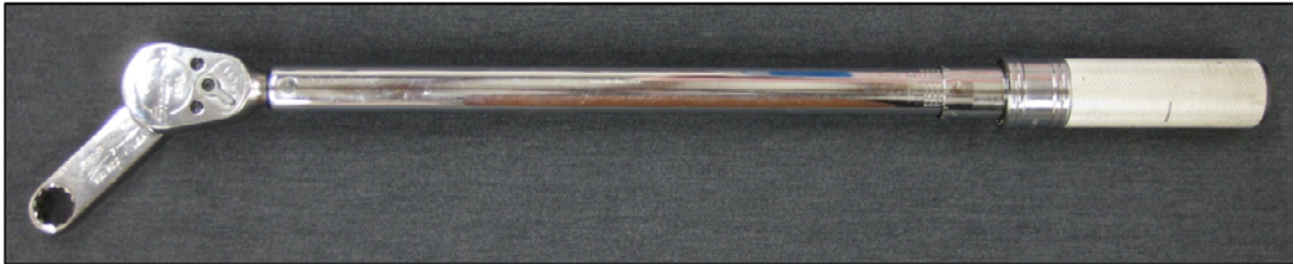

### STEP 1

When the adapter is at a 45 degree angle as shown in the photograph above, adjustment of the torque value is required.



## STEP 2

Determine effective length of torque adapter to torque wrench using the same methods as Step 1 in Example A.

In the following examples, the effective length of the 3 inch adapter used at 45 degrees is 2.125 inches.

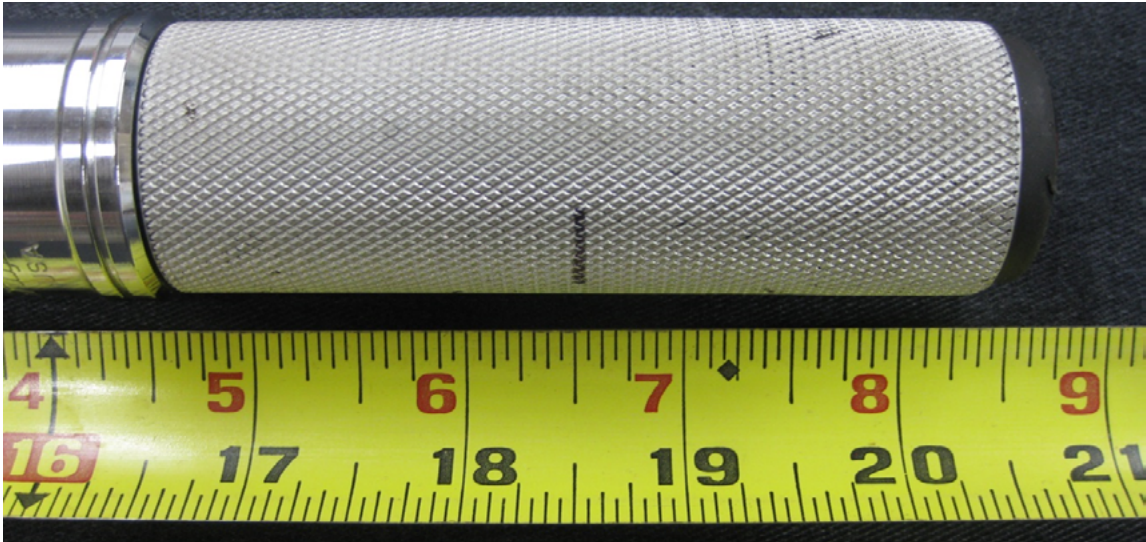

### STEP 3

Using the same torque wrench as in Example A, the torque wrench length is 18.5 inches.

### STEP 4

$(18.5 \times 180) / (18.5 + 2.125) = 3330 / 20.625 = 161 \text{ ft.-lbs.}$

A torque wrench setting of 161 ft.-lbs. is needed to adjust for the 3 inch torque adapter being used at a 45 degree angle.

---

### EXAMPLE C



### STEP 1

When the adapter is at a 90 degree angle as shown in the photograph above, no adjustment of the torque value is needed. The length of the adaptor is parallel to the wrench, meaning the distance is the same as if no adapter was being used.

## EXAMPLE D

### STEP 1

In example D, a universal joint or swivel socket is being used. The torque applied is not changed if the swivel is used at an angle of 15 degrees or less.

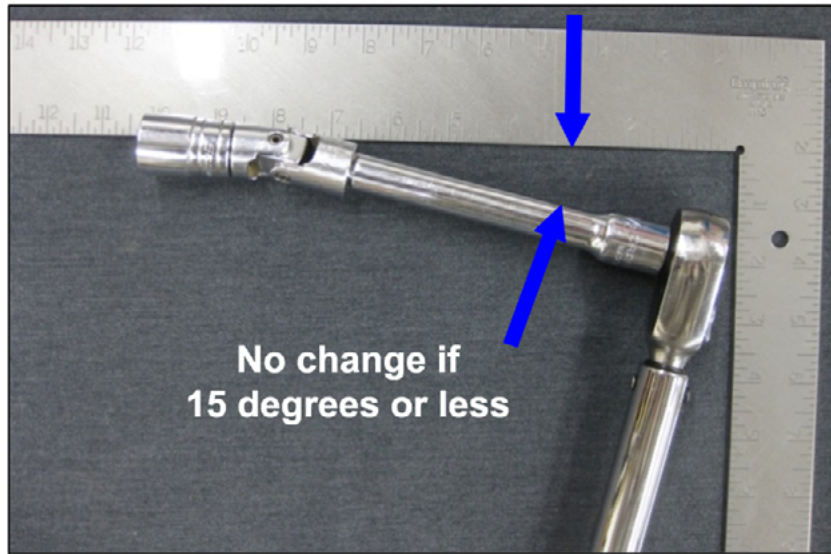

## EXAMPLE E



## STEP 1

In example E, the offset is 1.25 inches because of the crow foot wrench being used.

## STEP 2

The torque wrench length in this example is 13.5 inches.



## STEP 3

$(13.5 \times 180) / (13.5 + 1.25) = 2430 / 14.75 = 165 \text{ ft.-lbs.}$

A torque wrench setting of 165 ft.-lbs. is needed to adjust for the 1 inch offset while using the crow foot as shown to get a torque value of 180 ft.-lbs.



FOR FURTHER ASSISTANCE,  
CONTACT THE TEREX UTILITIES TECHNICAL SUPPORT TEAM  
PHONE: **1-844-TEREX4U (1-844-837-3948)** | EMAIL: **[UTILITIES.SERVICE@TEREX.COM](mailto:UTILITIES.SERVICE@TEREX.COM)**

---