

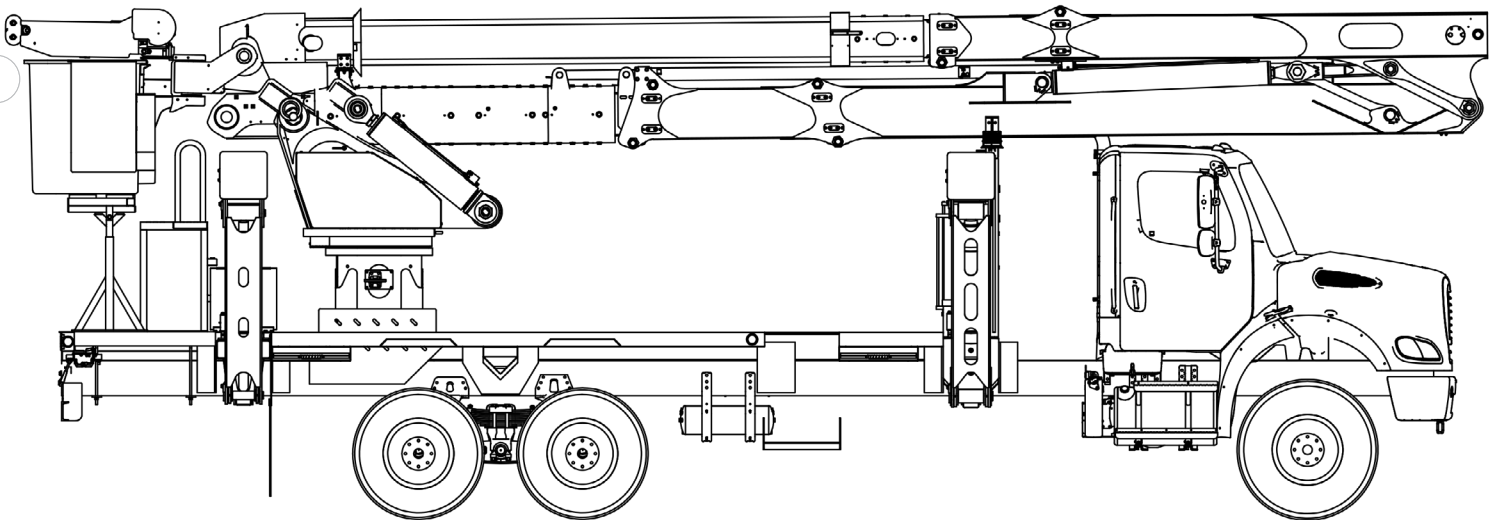

TECH TIPS

CHANGING A HIGH-PRESSURE FILTER

NO. 69



SERVICE CALL:
CHANGING A HIGH PRESSURE
FILTER



MODEL(S):
TC, TCX, RM, RMX, TM



TOOLS NEEDED:
7/8" SOCKET OR ADJUSTABLE
WRENCH

TEREX UTILITIES TECHNICAL SUPPORT TEAM

PHONE: 1-844-TEREX4U (1-844-837-3948) | EMAIL: UTILITIES.SERVICE@TEREX.COM

! WARNING



Injection Hazard
Fluid escaping under pressure can penetrate skin and result in death or serious injury.

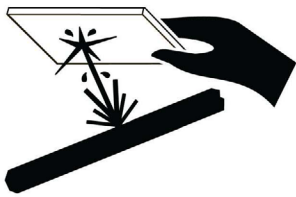

Relieve pressure before disconnecting hydraulic lines.
Stay clear of leaks and pin holes. Use a piece of cardboard or wood to search for leaks. Do not use hand.
Fluid injected into skin must be surgically removed within a few hours by a doctor familiar with this type of injury, or gangrene will result.



DANGER

Failure to obey the instructions and safety rules in the appropriate Operator's Manual and Service Manual for your machine will result in death or serious injury.

Many of the hazards identified in the Operator's Manual are also safety hazards when maintenance and repair procedures are performed.

DO NOT PERFORM MAINTENANCE UNLESS:

- ✓ You are trained and qualified to perform maintenance on this machine.
- ✓ You read, understand and obey:
 - manufacturer's instructions and safety rules
 - employer's safety rules and worksite regulations
 - applicable governmental regulations
- ✓ You have the appropriate tools, lifting equipment and a suitable workshop.

The information contained in this Tech Tip is a supplement to the Service Manual. Consult the appropriate Service Manual of your machine for safety rules and hazards.



TECH TIP 69 | RELEASED 05.06.2024 | VERSION 1.1
©TEREX UTILITIES. ALL RIGHTS RESERVED

CONTENTS

TECH TIP #69

TOC

4

| *Release the pressure*

STEP 1 - STEP 2

STEP 1

When replacing high pressure filters on a closed center system, remember to release the pressure in the system before removing it.

STEP 2

To release the pressure, move the handle on the outrigger valve back and forth repeatedly with the engine and the PTO OFF. Once the pressure is released, the filter can be easily removed.



Escaping fluid under pressure can penetrate skin causing serious injury.

Relieve pressure before disconnecting hydraulic lines. Keep away from leaks and pin holes. Use a piece of cardboard or paper to search for leaks. DO NOT use your hand.

Note: The TM series has two pumps. The large pump will relieve pressure as stated above. The small pump pressure requires the outriggers to be extended to activate the interlock valve. Once the outriggers are extended, move the Top Control selector to the ON position to relieve pressure in the system.

Note: If the TM series is not equipped with a generator for charging the leveling battery, a function at the option valve at the Top Controls must be actuated to relieve the pressure.

Then follow Step 2 to relieve the pressure in the large pump before attempting to remove the pressure filters.



FOR FURTHER ASSISTANCE,
CONTACT THE TEREX UTILITIES TECHNICAL SUPPORT TEAM
PHONE: **1-844-TEREX4U (1-844-837-3948)** | EMAIL: **UTILITIES.SERVICE@TEREX.COM**
