

**Service Call:**

Checking Fluid Levels in the Gearbox

**Tools Required:**

Hex Key Wrench Set

**Model(s):**

All Terex Models

## Tech Tip Safety Rules



### **Danger**

Failure to obey the instructions and safety rules in the appropriate Operator's Manual and Service Manual for your machine will result in death or serious injury. Many of the hazards identified in the operator's manual are also safety hazards when maintenance and repair procedures are performed.

### **Do Not Perform Maintenance Unless:**

- You are trained and qualified to perform maintenance on this machine.
- You read, understand and obey:
  - manufacturer's instructions and safety rules
  - employer's safety rules and worksite regulations
  - applicable governmental regulations
- You have the appropriate tools, lifting equipment and a suitable workshop.

The information contained in this tech tip is a supplement to the service manual. Consult the appropriate service manual of your machine for safety rules and hazards.

## Overview

Maintain the proper oil levels in all gearboxes to help dissipate heat. Overfilling the gearbox or have too little oil increases maintenance costs and downtime.

## Step 1

Consult the lube chart on the unit or in the unit specific manual for the unit for proper fluids.

**TEREX TELELECT**  
DIGGER DERRICK

ITEM	LUBRICATION POINT	QTY	TYPE OF LUBRICATION	SERVICE	
				INTERVAL	METHOD
1	2ND BOOM WEAR PADS	A/R	LITHIUM-BASE EP #2 GREASE	360 HOURS OR 90 DAYS	GREASE GUN
2	DIGGER BRACKET	4			
3	AUGER STORAGE BRACKET	1			
4	LIFT CYLINDER BEARINGS	4			
5	BOOM PIVOT BEARINGS	2			
6	TURN TABLE BEARING	*1			
7	JACKS, SWING SLANT	10			
8	ROTATION GEAR BOX BEARING	1			
9	WINCH DRUM	1			
10	HYDRAULIC 3RD ROLLERS	2			
11	ROTATION GEAR TEETH	*1			
12	WINCH GEAR BOX	**1	GL-5 EP GEARLUBE 85W140	360 HOURS OR 90 DAYS	***FILL IF LOW
13	DIGGER GEAR BOX	1	GL-5 EP GEARLUBE 80W90		
14	PLANETARY ROTATION GEAR BOX	1	GL-5 EP GEARLUBE 80W90		
15	WORM ROTATION GEAR BOX	1	MOBILUX EP 023		
16	HYDRAULIC RESERVE TANK	1	PREMIUM ISO 15 HYD FLUID	CHECK DAILY	
17	THROTTLE RESERVOIR	1	HYD FLUID MIL-5606A		
18	PLANETARY BRAKE	1	HYD FLUID MIL-5606A		
19	CONTROL LEVERS	A/R	LUBRICATING OIL	360 HOURS OR 90 DAYS	GREASE GUN
20	FBG 3RD WEAR PADS	A/R	LITHIUM EP #2 GREASE		SPRAY
21	3RD SIDE ROLLERS	4	SILICONE		
22	SHEAVES	A/R	SILICONE	WEEKLY	
23	RETURN LINE FILTER	1	REPLACE FILTER EVERY 250 HOURS		

USE THE ABOVE PRODUCTS OR EQUIVALENT  
 \* LUBR SPARINGLY EVERY 1/8 REVOLUTION.  
 \*\* FOR SERVICE BELOW -20° F, CONSULT OIL SUPPLIER.  
 \*\*\* DRAIN AND REFILL WHEN CONTAMINATED.  
 NOTE: ALL MOVING PARTS NOT EQUIPPED WITH GREASE FITTINGS SHOULD BE LUBRICATED WITH LPS-1 OR EQUIVALENT LUBRICANT EVERY 90 DAYS.

NOTE: ALWAYS LUBRICATE ITEMS WHEN DISASSEMBLED. DERRICKS MAY VARY SLIGHTLY WITH OPTIONS. LUBRICATE PER MANUAL.

443818D

## Step 2

Consult the unit specific maintenance manual to determine which position the gearbox needs to be in to check for the proper fluid level.

The following examples are for reference only, consult the unit specific manual for specific information.

### SECTION 660 WINCH GEARBOX

#### MAINTENANCE OF WORM GEAR WINCH (TULSA)

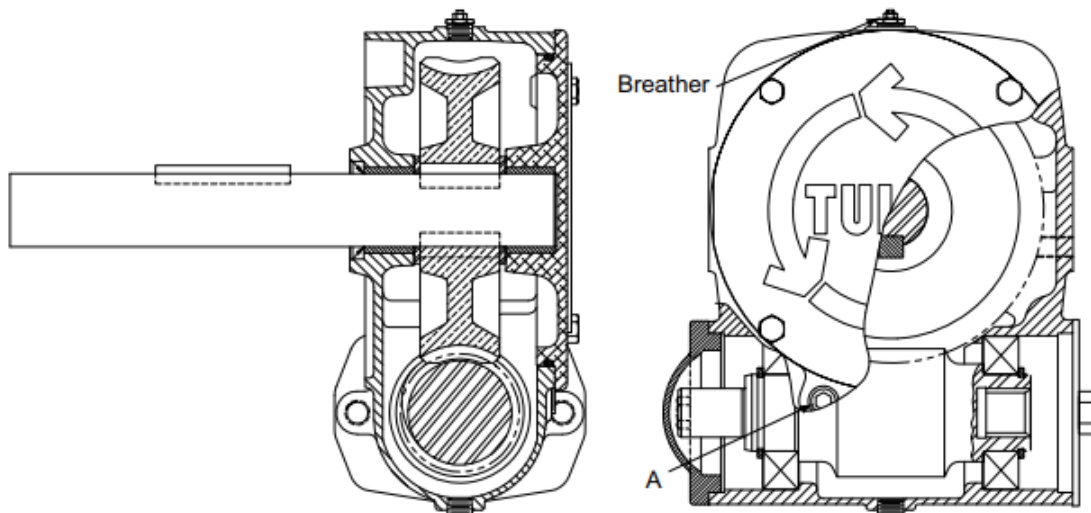

**NOTE:** Oil should be level with the bottom of the check/fill plug (A) when the winch is at the position shown. Maximum 120 hour interval.

Fill gearbox with EP 80/90 gear oil until it runs out of the fill plug while the auger drive is leaning approximately 3 1/2 inches from vertical (approximately 7 degrees). A dry gearbox will hold about 6 1/2 pints of oil in this condition.

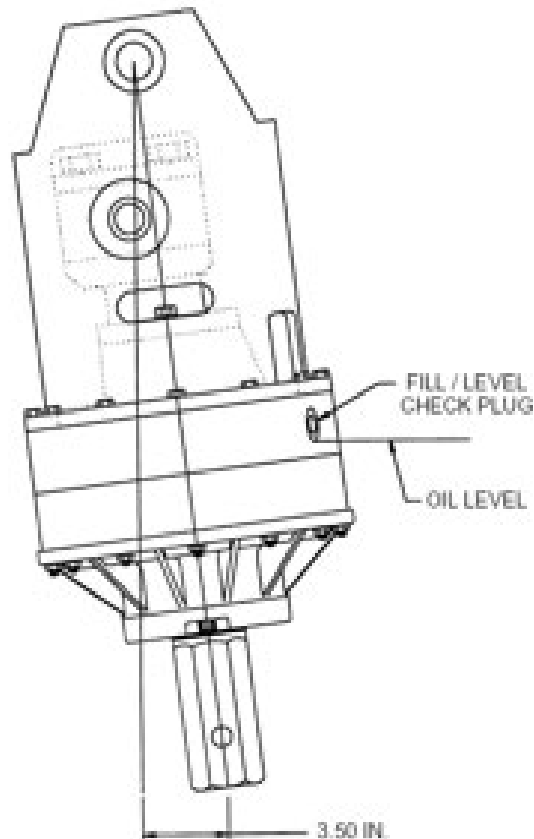

## Step 3

Locate the oil level plug on the gearbox. Use the proper size hex wrench to remove the plug.

## Step 4

With the plug removed, the oil level should be visible at the bottom of the hole.

## **Step 5**

If level is low, fill to proper level with the fluid indicated on the lube chart before reinstalling the plug.