

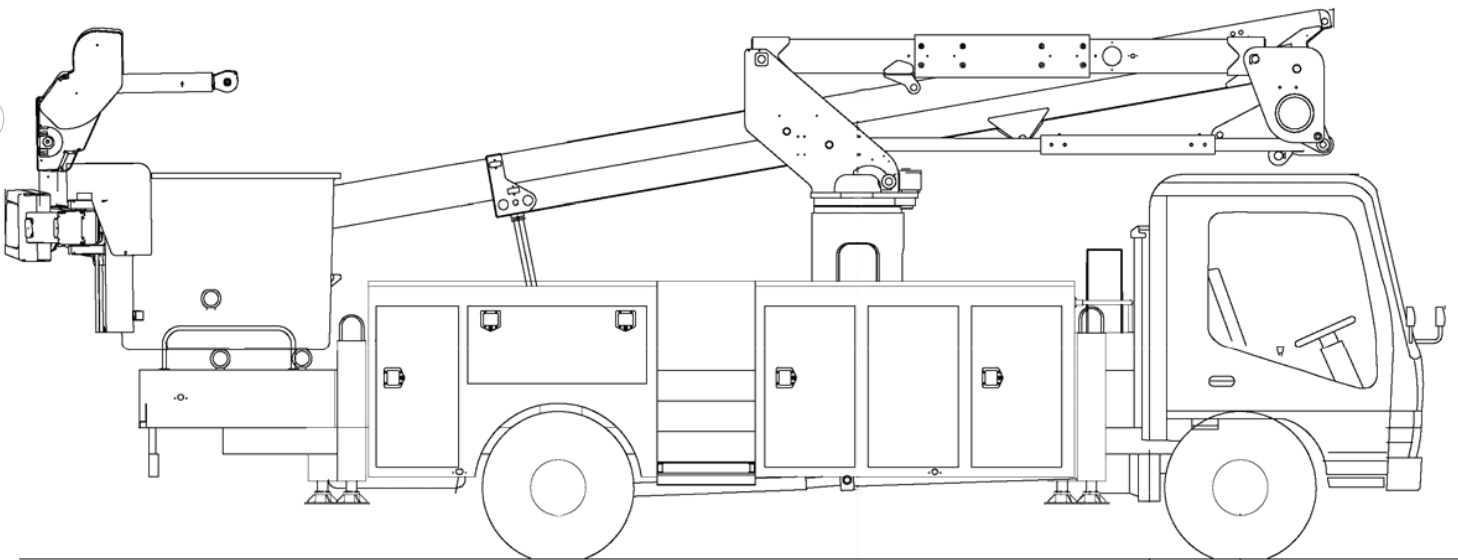

TECH TIPS

AC DIELECTRIC TESTING OF A CATEGORY C TELESCOPIC AERIAL DEVICE

NO. 93



SERVICE CALL:
AC DIELECTRIC TESTING OF A
CATEGORY C TELESCOPIC AERIAL
DEVICE



MODEL(S):
L131, L171, TL



TOOLS NEEDED:
AC DIELECTRIC TESTER
INSULATING OUTRIGGER PADS
SAFETY EQUIPMENT TO CREATE
A DIELECTRIC TEST AREA

TEREX UTILITIES TECHNICAL SUPPORT TEAM

PHONE: 1-844-TEREX4U (1-844-837-3948) | EMAIL: UTILITIES.SERVICE@TEREX.COM



DANGER

Failure to obey the instructions and safety rules in the appropriate Operator's Manual and Service Manual for your machine will result in death or serious injury.

Many of the hazards identified in the Operator's Manual are also safety hazards when maintenance and repair procedures are performed.

DO NOT PERFORM MAINTENANCE UNLESS:

- ✓ You are trained and qualified to perform maintenance on this machine.
- ✓ You read, understand and obey:
 - manufacturer's instructions and safety rules
 - employer's safety rules and worksite regulations
 - applicable governmental regulations
- ✓ You have the appropriate tools, lifting equipment and a suitable workshop.

The information contained in this Tech Tip is a supplement to the Service Manual. Consult the appropriate Service Manual of your machine for safety rules and hazards.



TECH TIP 93 | RELEASED 07.15.2024 | VERSION 1.1
©TEREX UTILITIES. ALL RIGHTS RESERVED

CONTENTS

TECH TIP #93

TOC

4 | *Test Area*
STEP 1

5 | *Inspect the unit*
STEP 2 - STEP 3

6 | *Install jumpers*
STEP 4

7 | *Attach current meter return*
Position booms at 45 degrees
STEP 5 - STEP 6

8 | *Run dielectric test*
STEP 7

9 | *Remove jumpers*
Set-up for lower boom
STEP 8 - STEP 11

10 | *Run dielectric test*
STEP 12

12 | *Remove jumpers*
Test control handle
STEP 13 - STEP 16

13 | *Run dielectric test*
STEP 17 - STEP 18

14 | *Remove spring*
Store unit
STEP 19 - STEP 20

STEP 1

In the interest of safety, the dielectric testing area should be separated from the normal work area by means of a barrier to keep anyone unassociated with the procedure out of the testing area. If a barrier is not available, use a spotter(s). The AC Dielectric Tester voltage source should also be contained within this area.

The test area must be free of any obstructions both on the ground and above/around the unit. The boom must not be near any trees, buildings or energized power lines when elevated for testing.

Consult the ID Placard to determine whether the unit is insulated or non-insulated. If the unit is insulated, the qualification voltage and rating of the unit will be shown.



Verify that the boom is designed as insulated before proceeding with the dielectric test.

Insulated /
Non-Insulated

Qualification
Voltage

Insulating
Category

MODEL	YEAR	UNIT EQUIPPED WITH	PLATFORM(S)
SERIAL NUMBER		LBS. PER PLATFORM	
RATED PLATFORM HEIGHT		TOTAL LBS. ALL PLATFORMS	
THIS DEVICE COMPLIES WITH REQUIREMENTS OF ANSI		EQUIPPED WITH MATERIAL HANDLING ATTACHMENT:	
		BOOM TIP	YES NO
		LOWER BOOM	
NON-INSULATED <input type="checkbox"/>	DESIGN VOLTAGE	INSULATING CATEGORY	
INSULATED <input type="checkbox"/>	QUALIFICATION VOLTAGE	DATE OF TEST	
CONFIGURED FOR GLOVING WORK		YES	NO
CHASSIS INSULATING SYSTEM			
HIGH RESISTANCE SINGLE STICK UPPER CONTROLS			
<u>CAPACITY RATING</u>			
SEE LOAD CHART PLATE(S) FOR SPECIFIC CONFIGURATION CAPACITIES.			
UNIT MUST BE OPERATED ON A FIRM AND LEVEL SURFACE WITH ALL THE OUTRIGGERS, WHEN SO EQUIPPED, EXTENDED DOWN TO A SOLID FOOTING. USE OUTRIGGER PADS.			
MAXIMUM PRESSURE (PSI):			
HYDRAULIC SYSTEM		PNEUMATIC SYSTEM	
HYDRAULIC WINCH		CONTROL SYSTEM VOLTAGE	
<u>OPERATION</u>			
WARNING: BEFORE OPERATING UNIT, READ AND UNDERSTAND ALL OPERATING AND SAFETY INFORMATION IN MANUALS AND ALL INFORMATION ON DECALS, LABELS, AND THIS PLACARD.			
GENERAL INSTRUCTIONS:			
1. Lubricate unit per lubrication chart.			
2. Inspect for visible defects or loose objects.			
3. Check insulated boom and other insulating material for cleanliness.			
4. Check all decals for legibility. Replace if necessary.			
5. Set vehicle park brake securely before operation.			
6. Start engine or engage power take off (PTO).			
7. Extend all hydraulic outriggers to a solid footing.			
8. Operate all hydraulic controls slowly and deliberately for smooth movements.			
9. Minimum ambient temperature for operation ° F. Maximum ° F. (See Manual)			
10. If configured for gloving work, all boom tip covers must be undamaged and in place.			
<u>ATTENTION</u>			
1. Do not alter components without written approval from the manufacturer. All updates in effect, (Both the manufacturer as well as ANSI/OSHA) at the time of rebuild should be performed.			
2. If unit is remounted by entity other than a Terex South Dakota approved distributor, Terex South Dakota must be contacted to insure that mounting is completed to specifications.			
3. If unit is resold, Terex South Dakota must be notified in writing, within 60 days, of new owner and what steps were taken to instruct the new owner as to the operation and maintenance of the unit. Copies of operators and maintenance manuals must accompany the unit at the time of sale.			
4. All recalls issued by Terex South Dakota must be completed at the time of sale.			
THIS UNIT WAS INSTALLED BY:			
DATE OF COMPLETED UNIT TESTS:			
		Terex South Dakota, Inc. 3140 15th Ave SE Watertown, South Dakota 57201 USA	16453AL

STEP 2

Complete a thorough daily inspection of the unit, including running all boom functions through their full range of motion before beginning any dielectric testing. Daily inspection criteria can be found in the unit specific operators and maintenance manuals.

The fiberglass booms must be clean, dry and in good physical condition. Check carefully for any bird's nests, material buildup, or hydraulic leaks in the boom or control areas. Check under the boom tip covers and look down each boom from both ends checking for a blockage or any signs of a leak. A bird's nest, blockage, or leak in the boom could ignite and cause a fire during the dielectric test.

If a blockage or leak is found it must be repaired and the unit cleaned prior to continuing with the dielectric test.

Record all unit info and weather conditions on the dielectric test sheet prior to starting the test. The test sheets are included in the Manual and can be copied as needed.

STEP 3

Drive the unit into the dielectric testing area and onto the insulating platforms (pads) centered under the tires. Engage the park brake, place the transmission in neutral and turn on the PTO.

Set the unit up for operation by deploying the outriggers onto insulating platforms (pads) centered under the outrigger foot, reference **Figure 1**. Once outrigger setup is complete, shift the outrigger/unit selector into the unit position.

The boom can be brought to the ground mount position to aid in set-up during the next steps.

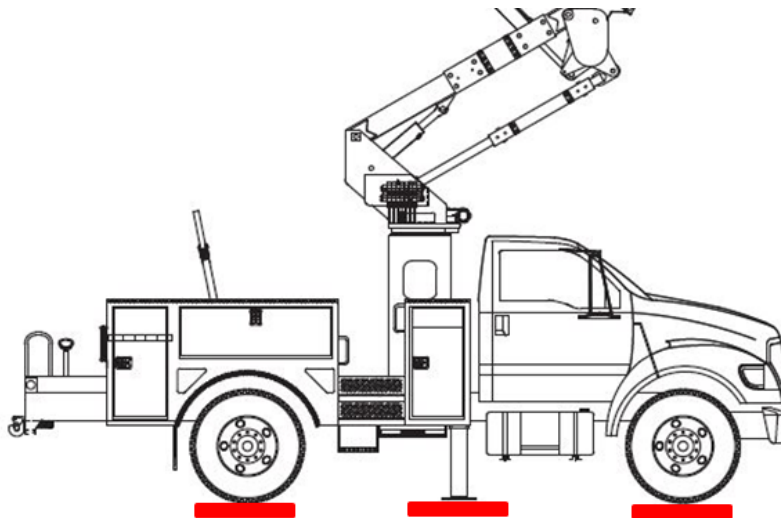

FIGURE 1

STEP 4

To begin setup for testing the upper boom, install jumpers between components in the following locations as shown in **Figure 2**:

- Turntable above rotation to pedestal below rotation (#1)
- Turntable above rotation to lower boom (#2)
- Lower boom insert (#3)
- Upper boom to knuckle (#4)
- Knuckle to lower boom (#5)
- Platform bracket to boom tip bracket (#6)
- Jib bracket (if equipped) to platform bracket (#7)

Verify that the jumpers make good contact by removing paint, if needed, at the attachment location prior to attaching the jumpers. Some units are equipped with stainless bolts specifically for dielectric testing, use these if equipped.

The jumpers and connections are shown in RED in the following Figures. They do not reflect the actual connection points where the jumpers are installed on the unit, but are only a reference to the general location.

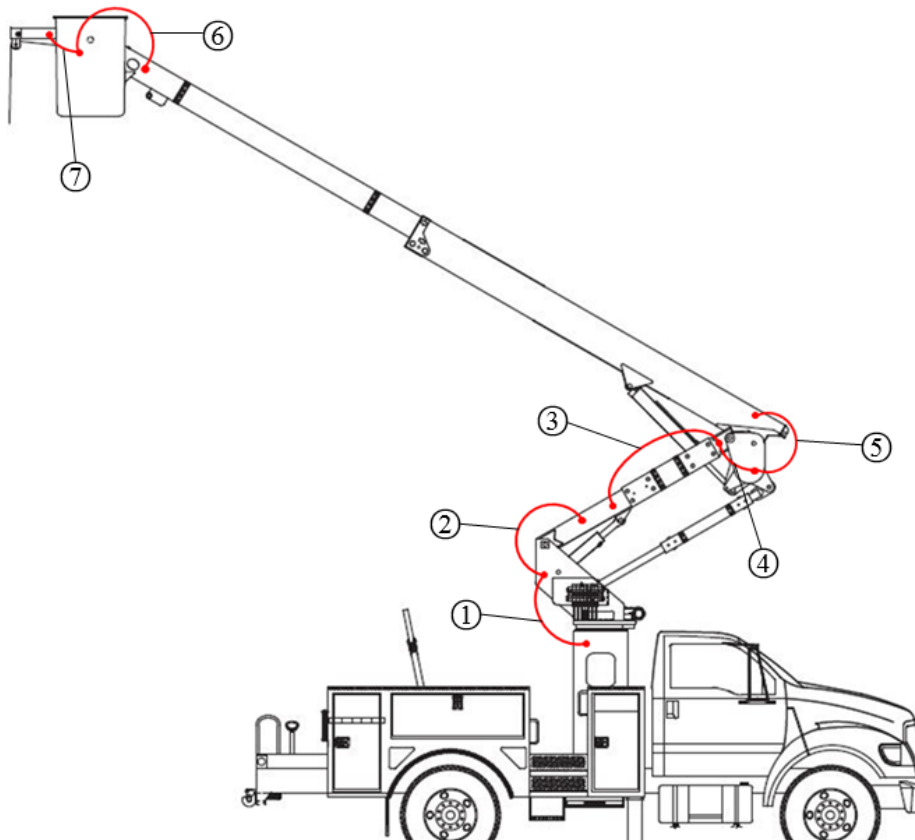

FIGURE 2

STEP 5

Attach the current meter return to the back of the truck. If a ground lug or loop is available, attach the return there.

Attach the voltage source from the AC Dielectric Tester to the boom tip. This may be attached at the same location as the jumpers that were installed at the boom tip. See Figure 3. Keep the test machine directly below or away from the truck if possible.

Follow the instructions of the dielectric testing machine for any further connections that are required. Verify that the dielectric tester has been grounded.

STEP 6

Position the lower and upper booms both at 45 degrees. Extend the upper boom to the minimum extension decal (if equipped).

Visually check that all jumpers, voltage source from the AC Dielectric Tester, and return are still connected once unit is in position. See **Figure 3**.

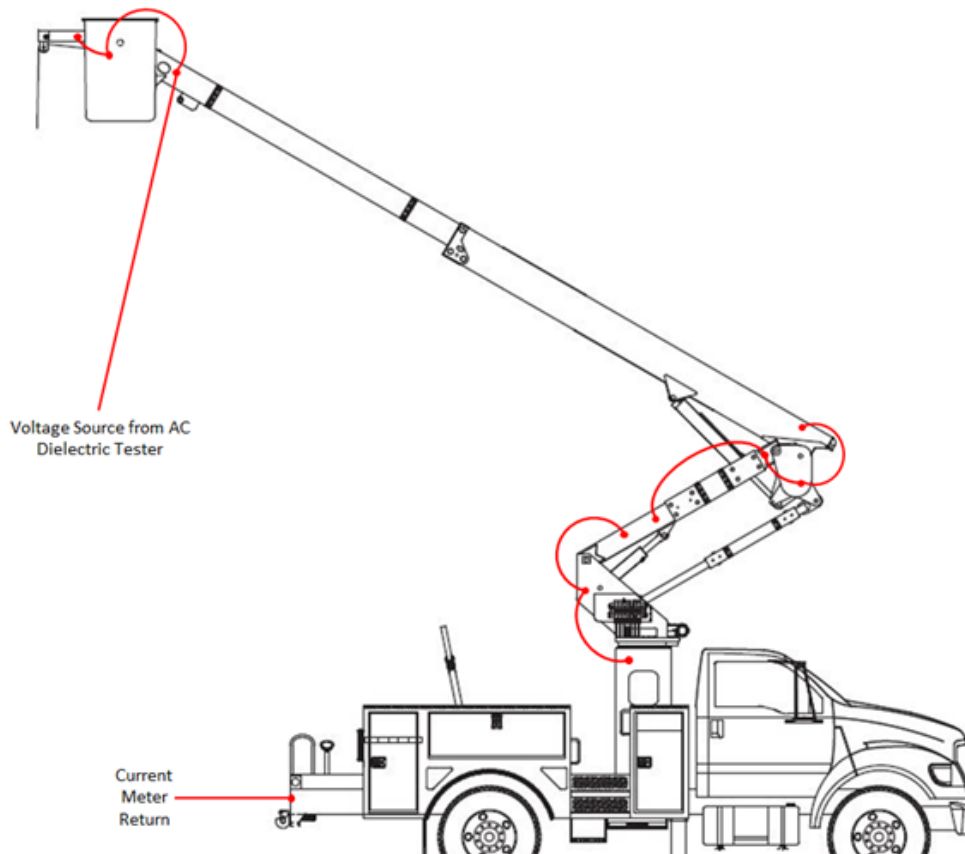

FIGURE 3

STEP 7

Plug in and turn on the dielectric tester. Raise the voltage control to the required voltage listed on the test sheet. Monitor the volt and current meters to verify the test is working correctly. If the current meter reads zero verify all connections.

If the current meter value stays below the Max Leakage, continue the test until complete, record readings, return the voltage control to 0, turn off and unplug the dielectric machine.

If the current meter value exceeds the Max Leakage at any point during the test, return the voltage control to 0, turn off and unplug the dielectric machine. Begin troubleshooting to determine why the boom will not pass the dielectric test. Reference Tech Tip #51 for further troubleshooting help.

The upper boom Qualification and Periodic readings are shown below. Qualification testing is done on a new unit install or after a major component such as a boom is replaced. Periodic testing is done once a year to verify dielectric integrity of the unit.

For a Category C AC Qualification test, the reading should be no higher than 1000 μ A for 3 minutes at 100 KV.

For a Category C AC Periodic/Maintenance Test the reading should be no higher than 400 μ A for 1 minute at 40 KV.

μ A=Microamp

UNIT QUALIFICATION		TEST TIME	3 MINUTE AC TEST VOLTAGE	
VOLTAGE AC		AM PM	100 kv	
46 kv & below		Start		μ A
		Finish		μ A
S/N _____		Max Leakage		1000 μ A

Unit Qualification Voltage	AC TEST - 1 Minute			DC TEST - 3 Minutes		
	TEST VOLTAGE	Time	Leakage	TEST VOLTAGE	Time	Leakage
46 KV & Below	40KV	Start	μ A	56 KV	Start	μ A
		Finish	μ A		Finish	μ A
		Max. Leakage	400 μ A		Max. Leakage	56 μ A
[] KV	[] KV	Start	μ A	[] KV	Start	μ A
		Finish	μ A		Finish	μ A
		Max. Leakage	μ A		Max. Leakage	μ A

STEP 8

Once testing is complete bring the upper and lower booms down to the ground mount position. Disconnect the voltage source from the boom.

STEP 9

Remove the following jumpers:

- Turntable above rotation to pedestal below rotation (#1)
- Lower boom insert (#3)
- Upper boom to knuckle (#4)
- Knuckle to lower boom (#5)
- Platform bracket to boom tip bracket (#6)
- Jib bracket (if equipped) to platform bracket (#7)

See **Figure 2** to identify jumpers.

STEP 10

To begin setup for testing the lower boom, raise the upper boom up to a 45 degree angle. Raise the lower boom high enough to clear all obstacles and rotate the turntable 180 degrees so that the knuckle is off the back of the unit as shown in **Figure 4**.

STEP 11

Attach the voltage source from the AC Dielectric Tester to the knuckle side of the lower boom and install jumpers between components in the following locations as shown in **Figure 4**:

- Lower boom to knuckle (#1)
- Lower boom link to knuckle (#2)
- Turntable above rotation to pedestal below rotation (#3)
- Lower boom link to turntable (#4)

Raise the lower boom to at least a 45 degree angle.

Visually check that all jumpers, voltage source from the dielectric tester and the return are still connected once the unit is in position.

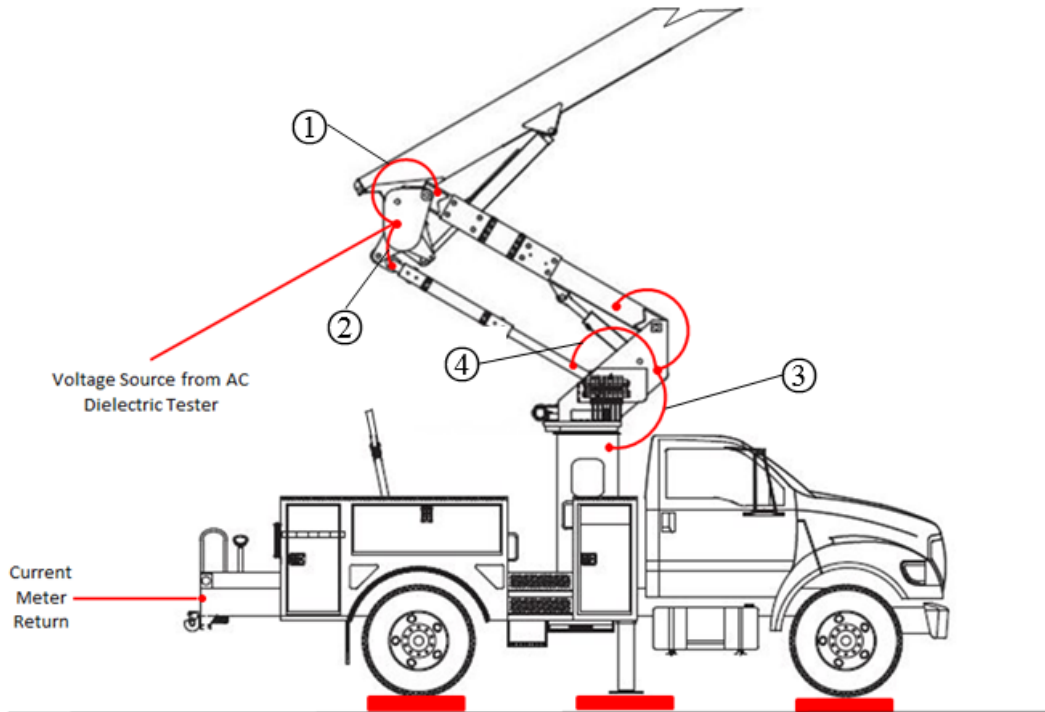

FIGURE 4

STEP 12

Plug in and turn on the dielectric tester. Raise the voltage control to the required voltage listed on the test sheet. Monitor the volt and current meters to verify that the test is working correctly.

If the current meter value stays below the Max Leakage continue test until complete, record readings, return the voltage control to 0, turn off and unplug the dielectric machine.

If the current meter value exceeds the Max Leakage at any point during the test return the voltage control to 0, turn off and unplug the dielectric machine. Begin troubleshooting to determine why the boom will not pass the dielectric test. **Reference Tech-tip #51** for further troubleshooting help.

STEP 12 (Continued)

The lower boom Qualification and Periodic readings are shown below.

For a Chassis Insulating System (Lower Boom Insert) Qualification test, the reading should be no higher than 3000 μA for 3 minutes at 50 KV.

			TEST TIME	3 MINUTE AC TEST VOLTAGE	
			AM PM	50 kv	
			Start		μA
			Finish		μA
S/N _____			Max Leakage		3000 μA

For a Chassis Insulating System (Lower Boom Insert) Periodic/Maintenance test the reading should be no higher than 3000 μA for 1 minute at 35 KV.

AC TEST - 1 Minute		
TEST VOLTAGE	Time	Leakage
35 KV	Start	μA
	Finish	μA
	Max. Leakage	3000 μA

STEP 13

Once testing is complete bring the lower boom down and disconnect the voltage source from the boom.

Remove all of the jumpers from the following locations indicated in **Figure 4**:

- Lower boom to knuckle (#1)
- Lower boom link to knuckle (#2)
- Turntable above rotation to pedestal below rotation (#3)
- Lower boom link to turntable (#4)

Remove the return from the back of the truck.

STEP 14

To begin setup for testing the upper control handle, bring the platform to the ground mount position at the back of the truck.

STEP 15

Attach the voltage source from the AC Dielectric Tester to the control handle using a spring with the cable going over the top of the platform as shown below.



STEP 16

Reach under the upper control cover and attach the current meter return to a fitting that is attached to the upper control valve as shown below. (Cover removed for clarity).



STEP 17

Elevate the platform to at least 4 feet above the ground. Visually check that all jumpers, the voltage source from the dielectric tester, and the return are still connected once the unit is in position.

STEP 18

Plug in and turn on the dielectric tester. Raise the voltage control to the required voltage listed on the test sheet. Monitor the volt and current meters to verify that the test is working correctly.

If the current meter value stays below the Max Leakage continue the test until it is complete, record readings, return the voltage control to 0, turn off and unplug the dielectric machine.

If the current meter value exceeds the Max Leakage at any point during the test, return the voltage control to 0, turn off and unplug the dielectric machine. Begin troubleshooting to determine why the single stick control handle will not pass the dielectric test.

The Single Stick Qualification and Periodic readings are shown below.

For a Single Stick Control AC Qualification and Periodic/ Maintenance test the reading should be no higher than 400 μA for 3 minutes at 40 KV.

μA =Microamp

Test time: AM / PM 3 minutes		AC test (40KVAC)	Leakage
Start			μA
Finish			μA
		Allowable	400 μA

STEP 19

Once testing is complete lower the platform to the ground mount position. Remove the spring from the control handle and current meter return from the upper control valve fitting.

STEP 20

Store the unit and raise the outriggers. Remove any barriers around the unit and drive the unit off the pads and out of the dielectric test area.



FOR FURTHER ASSISTANCE,
CONTACT THE TEREX UTILITIES TECHNICAL SUPPORT TEAM
PHONE: [1-844-TEREX4U \(1-844-837-3948\)](tel:1-844-TEREX4U) | EMAIL: UTILITIES.SERVICE@TEREX.COM
