

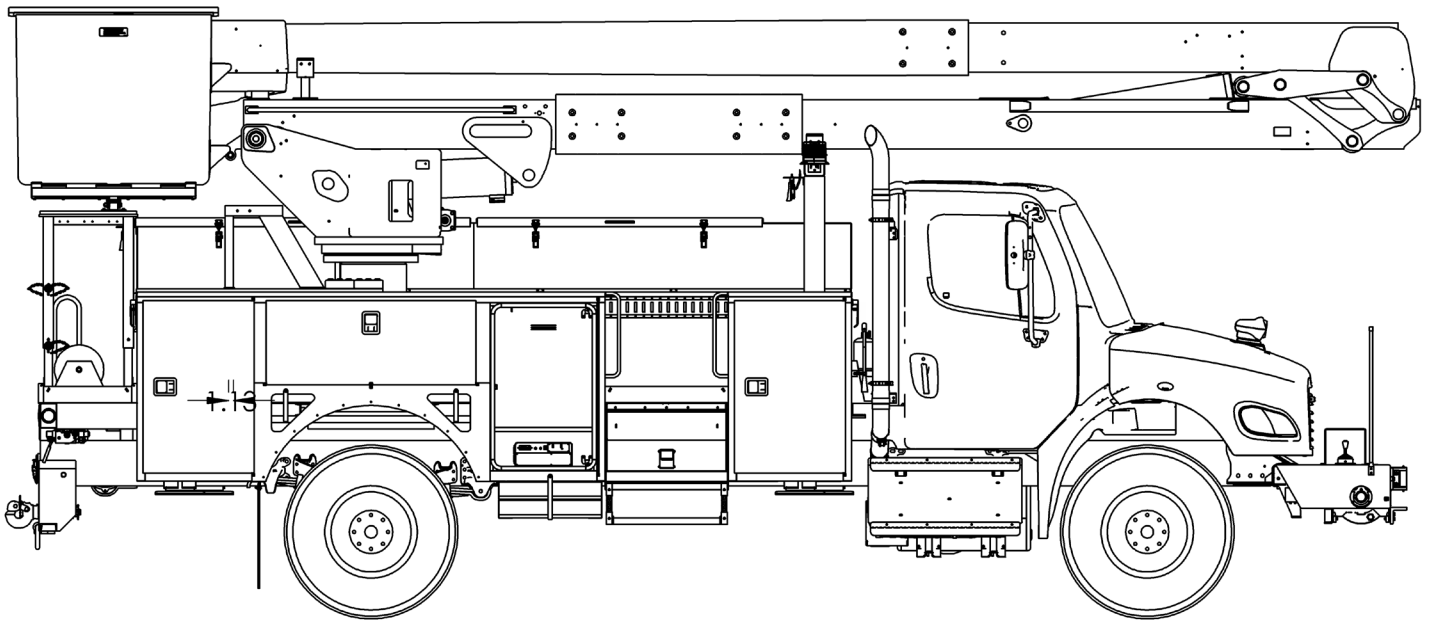

TECH TIPS

AC DIELECTRIC TESTING OF A CATEGORY B AERIAL DEVICES

NO. 94



SERVICE CALL:
AC DIELECTRIC TESTING OF A
CATEGORY B AERIAL DEVICE



MODEL(S):
TCX



TOOLS NEEDED:
AC DIELECTRIC TESTER
INSULATING OUTRIGGER PADS
MULTIMETER CAPABLE OF
MEASURING RESISTANCE (OHMS)
SAFETY EQUIPMENT TO CREATE
A DIELECTRIC TEST AREA

TEREX UTILITIES TECHNICAL SUPPORT TEAM

PHONE: 1-844-TEREX4U (1-844-837-3948) | EMAIL: UTILITIES.SERVICE@TEREX.COM



DANGER

Failure to obey the instructions and safety rules in the appropriate Operator's Manual and Service Manual for your machine will result in death or serious injury.

Many of the hazards identified in the Operator's Manual are also safety hazards when maintenance and repair procedures are performed.

DO NOT PERFORM MAINTENANCE UNLESS:

- ✓ You are trained and qualified to perform maintenance on this machine.
- ✓ You read, understand and obey:
 - manufacturer's instructions and safety rules
 - employer's safety rules and worksite regulations
 - applicable governmental regulations
- ✓ You have the appropriate tools, lifting equipment and a suitable workshop.

The information contained in this Tech Tip is a supplement to the Service Manual. Consult the appropriate Service Manual of your machine for safety rules and hazards.



TECH TIP 94 | RELEASED 05.15.2024 | VERSION 1.1
©TEREX UTILITIES. ALL RIGHTS RESERVED

CONTENTS

TECH TIP #94

4 | *Set-up*
STEP 1 - STEP 3

6 | *Inspect and test the lower test electrode system*
STEP 4

7 | *Install jumpers*
STEP 5 - STEP 6

9 | *Attach the current meter*
STEP 7 - STEP 8

10 | *Plug in and turn on the dielectric tester*
STEP 9

11 | *Testing the lower boom*
STEP 10 - STEP 13

12 | **STEP 14 - STEP 15**

13 | *Testing upper control handle*
STEP 16 - STEP 17

14 | **STEP 18 - STEP 21**

15 | **STEP 22 - STEP 23**

STEP 1

In the interest of safety, the dielectric testing area should be separated from the normal work area by means of a barrier to keep anyone unassociated with the procedure out of the testing area. If a barrier is not available, use a spotter(s). The AC Dielectric Tester voltage source should also be contained within this area.

The test area must be free of any obstructions both on the ground and above/around the unit. The boom must not be near any trees, buildings or energized power lines when elevated for testing.



Verify that the boom is designed as insulated before proceeding with the dielectric test.

STEP 2

Consult the ID Placard to determine whether the unit is insulated or non-insulated. If the unit is insulated, the qualification voltage and rating of the unit will be shown. **Figure 1 and 2**

Units which have been tested and rerated at higher than 69KV will have a rerate tag alongside the ID plate showing the new rating.

STEP 3

Complete a thorough daily inspection of the unit, including running all boom functions through their full range of motion before beginning any dielectric testing. Daily inspection criteria can be found in the unit specific operators and maintenance manuals.

The fiberglass booms must be clean, dry and in good physical condition. Check carefully for any bird's nests, material buildup, or hydraulic leaks in the boom or control areas. Check under the boom tip covers and look down each boom from both ends checking for a blockage or any signs of a leak. A bird's nest, blockage, or leak in the boom could ignite and cause a fire during the dielectric test.

If a blockage or leak is found it must be repaired and the unit cleaned prior to continuing with the dielectric test.

Record all unit info and weather conditions on the dielectric test sheet prior to starting the test. The test sheets are included in the unit specific manual and can be copied as needed.

MODEL	YEAR	UNIT EQUIPPED WITH LBS. PER PLATFORM TOTAL LBS. ALL PLATFORMS	PLATFORM(S)
SERIAL NUMBER	EQUIPPED WITH MATERIAL HANDLING ATTACHMENT: YES NO		
RATED PLATFORM HEIGHT	BOOM TIP LOWER BOOM		
THIS DEVICE COMPLIES WITH REQUIREMENTS OF ANSI		DESIGN VOLTAGE	INSULATING CATEGORY
<input type="checkbox"/> NON-INSULATED <input type="checkbox"/> INSULATED		<input type="checkbox"/> QUALIFICATION VOLTAGE YES NO	DATE OF TEST
CONFIGURED FOR GLOVING WORK CHASSIS INSULATING SYSTEM HIGH RESISTANCE SINGLE STICK UPPER CONTROLS			
<u>CAPACITY RATING</u>			
SEE LOAD CHART PLATE(S) FOR SPECIFIC CONFIGURATION CAPACITIES. UNIT MUST BE OPERATED ON A FIRM AND LEVEL SURFACE WITH ALL THE OUTRIGGERS, WHEN SO EQUIPPED, EXTENDED DOWN TO A SOLID FOOTING. USE OUTRIGGER PADS.			
MAXIMUM PRESSURE (PSI):			
HYDRAULIC SYSTEM		PNEUMATIC SYSTEM	
HYDRAULIC WINCH		CONTROL SYSTEM VOLTAGE	
<u>OPERATION</u>			
WARNING: BEFORE OPERATING UNIT, READ AND UNDERSTAND ALL OPERATING AND SAFETY INFORMATION IN MANUALS AND ALL INFORMATION ON DECALS, LABELS, AND THIS PLACARD.			
GENERAL INSTRUCTIONS:			
<ol style="list-style-type: none"> Lubricate unit per lubrication chart. Inspect for visible defects or loose objects. Check insulated boom and other insulating material for cleanliness. Check all decals for legibility. Replace if necessary. Set vehicle park brake securely before operation. Start engine or engage power take off (PTO). Extend all hydraulic outriggers to a solid footing. Operate all hydraulic controls slowly and deliberately for smooth movements. Minimum ambient temperature for operation ° F. Maximum ° F. (See Manual) If configured for gloving work, all boom tip covers must be undamaged and in place. 			
<u>ATTENTION</u>			
<ol style="list-style-type: none"> Do not alter components without written approval from the manufacturer. All updates in effect, (Both the manufacturer as well as ANSI/OSHA) at the time of rebuild should be performed. If unit is remounted by entity other than a Terex South Dakota approved distributor, Terex South Dakota must be contacted to insure that mounting is completed to specifications. If unit is resold, Terex South Dakota must be notified in writing, within 60 days, of new owner and what steps were taken to instruct the new owner as to the operation and maintenance of the unit. Copies of operators and maintenance manuals must accompany the unit at the time of sale. All recalls issued by Terex South Dakota must be completed at the time of sale. 			
THIS UNIT WAS INSTALLED BY:			
DATE OF COMPLETED UNIT TESTS:			
		Terex South Dakota, Inc. 16453AL 3140 15th Ave SE Watertown, South Dakota 57201 USA	

Insulated /
Non-Insulated

Qualification
Voltage

Insulating
Category

FIGURE 1

REVISED ELECTRICAL RATING INFORMATION			
[REDACTED] MODEL		[REDACTED] SERIAL NUMBER	
The Original ID Plate applies except for Insulation Rating. The Electrical Rating ONLY complies with:			
ANSI	[REDACTED]	INSULATING CATEGORY	[REDACTED]
NON-INSULATED	<input type="checkbox"/>	QUALIFICATION VOLTAGE	[REDACTED]
INSULATED	<input type="checkbox"/>	DATE OF TEST	[REDACTED]
		Terex South Dakota 439225B 500 Oakwood Road PO Box 1150 Watertown, South Dakota 57201 USA	

Insulating
Category

Qualification
Voltage

FIGURE 2

STEP 4

Inspect and test the Lower Test Electrode System.

This is done by checking for “Electrical Continuity” between the center core of the Amphenol connector on the boom and the locations listed below. There should be less than 100 OHMS of resistance shown on the meter. It will typically be less than 5 OHMS.

- Outer Test Band
- Inner Test Band
- Hose Assembly Bulkhead
- PVC Tube Bands
- Leveling Rod Bands



Testing for “Electrical Insulation” between the center core of the Amphenol connector on the boom and steel elbow will also need to be completed. There should be more than 10,000 OHMS of resistance shown on the meter. It will typically be over 1 MOHM.

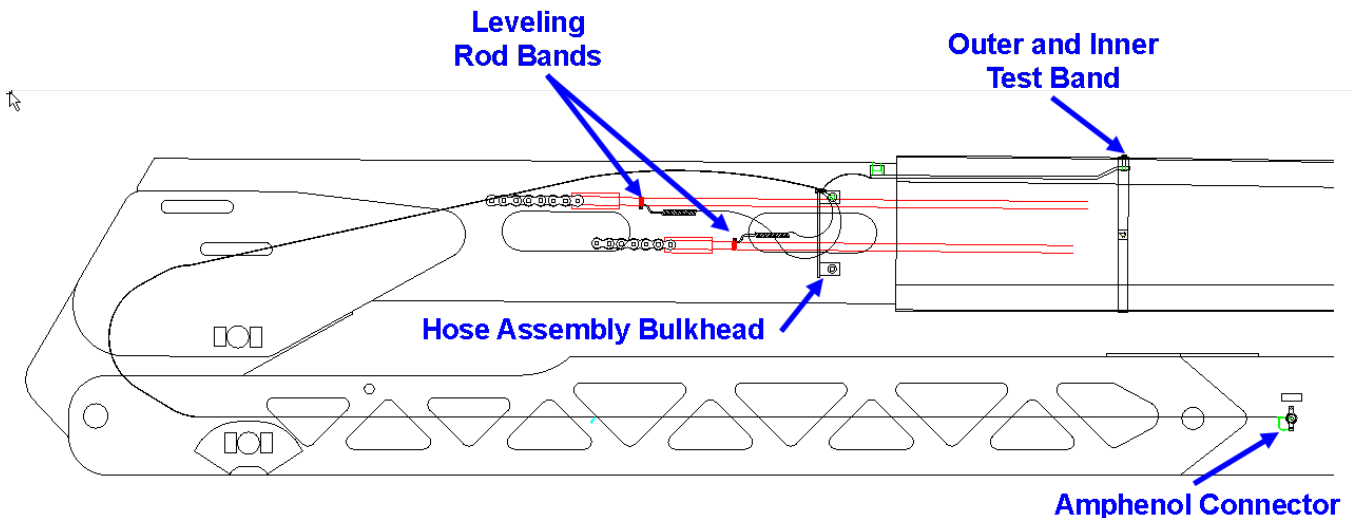

STEP 5

Drive the unit into the dielectric testing area and onto the insulating platforms (pads) centered under the tires. Engage the park brake, place the transmission in neutral and turn on the PTO.

Set the unit up for operation by deploying the outriggers onto insulating platforms (pads) centered under the outrigger foot, reference Figure 5. Once outrigger setup is complete, shift the outrigger/unit selector into the unit position.

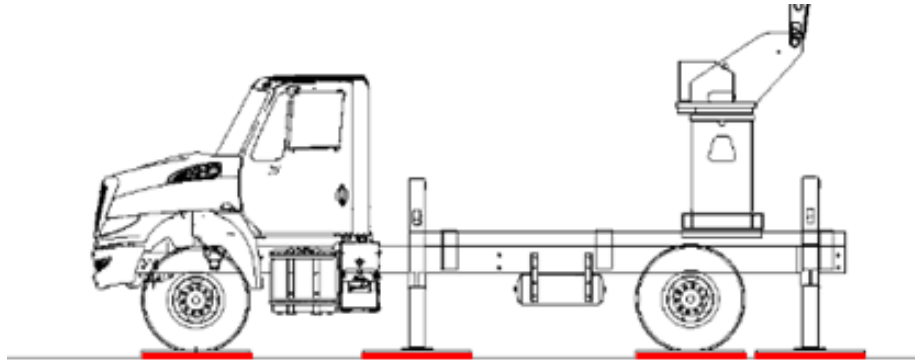

FIGURE 5

STEP 6

To begin setup for testing the upper boom, install jumpers between components in the following locations as shown in Figure 6:

- Turntable above rotation to pedestal below rotation (#1)
- Turntable above rotation to lower boom (#2)
- Lower boom insert (#3)
- Upper boom to Lower Boom (#4)
- Platform bracket to boom tip bracket (#5)
- Jib bracket (if equipped) to platform bracket
- Truck chassis to earth ground (#6)

Verify that the jumpers make good contact by removing paint, if needed, at the attachment location prior to attaching the jumpers. Some units are equipped with stainless bolts specifically for dielectric testing, use these if equipped. For the truck chassis to earth ground use the ground lug or loop if available at the rear of the truck.

STEP 6 (Continued)

The jumpers and connections are shown in RED in the following Figures. They do not reflect the actual connection points where the jumpers are installed on the unit but are only a reference to the general location.

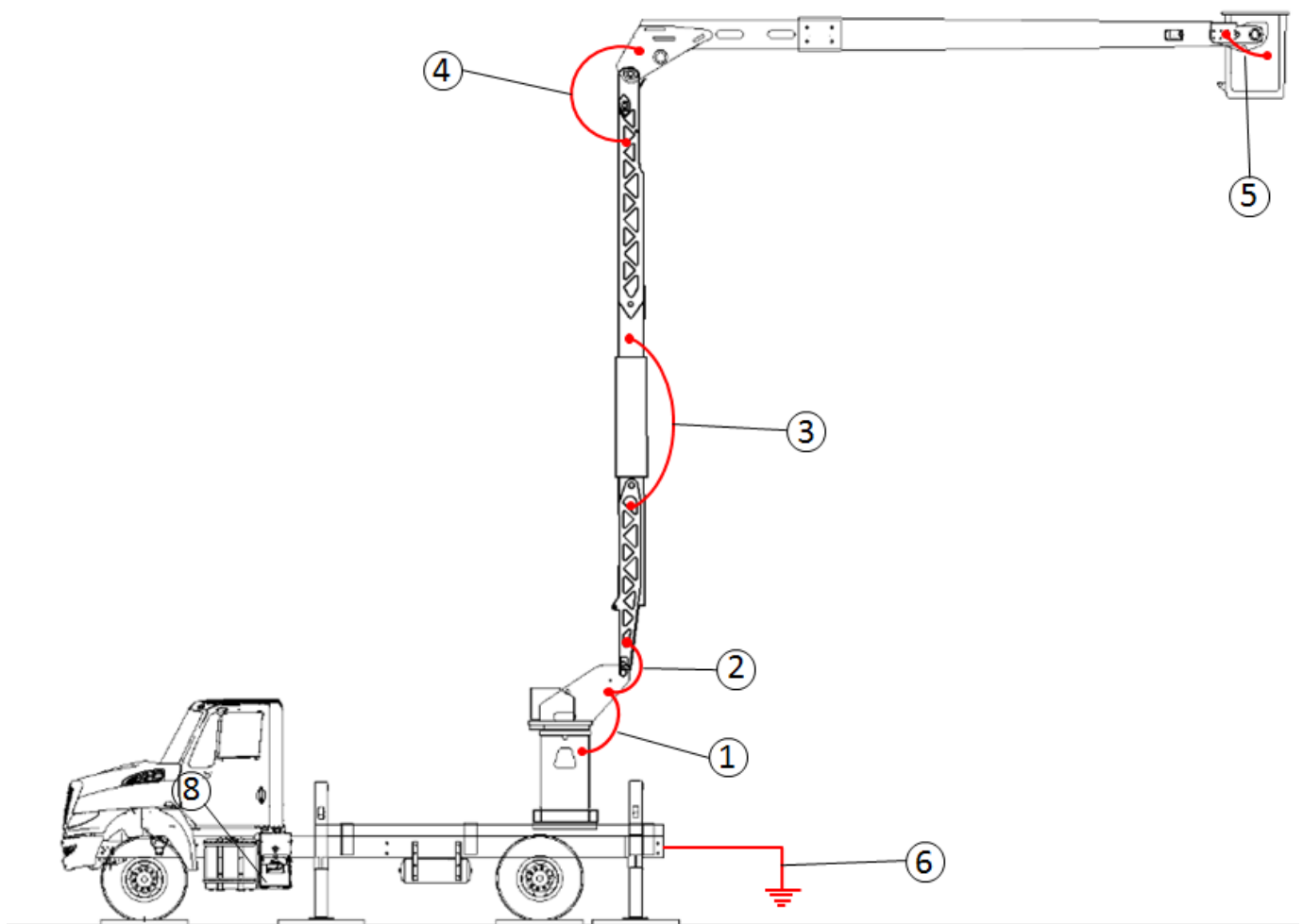

FIGURE 6

STEP 7

Attach the current meter return to the Amphenol connector shown in Step 4. The connector is located on the lower boom just forward of the lower boom insert.

Attach the voltage source from the AC Dielectric Tester to the boom tip. This may be attached at the same location as the jumpers that were installed at the boom tip. See Figure 7. Keep the test machine directly below or away from the truck if possible.

Follow the instructions of the dielectric testing machine for any further connections that are required. Verify that the dielectric tester has been grounded.

STEP 8

Position the lower boom at 90 degrees and upper booms at 0 degrees

Visually check that all jumpers, voltage source from the AC Dielectric Tester, and Current Meter Return at the Amphenol Connector are still connected once unit is in position. See Figure 3.



The dielectric tester controls should be located outside the dielectric test area.

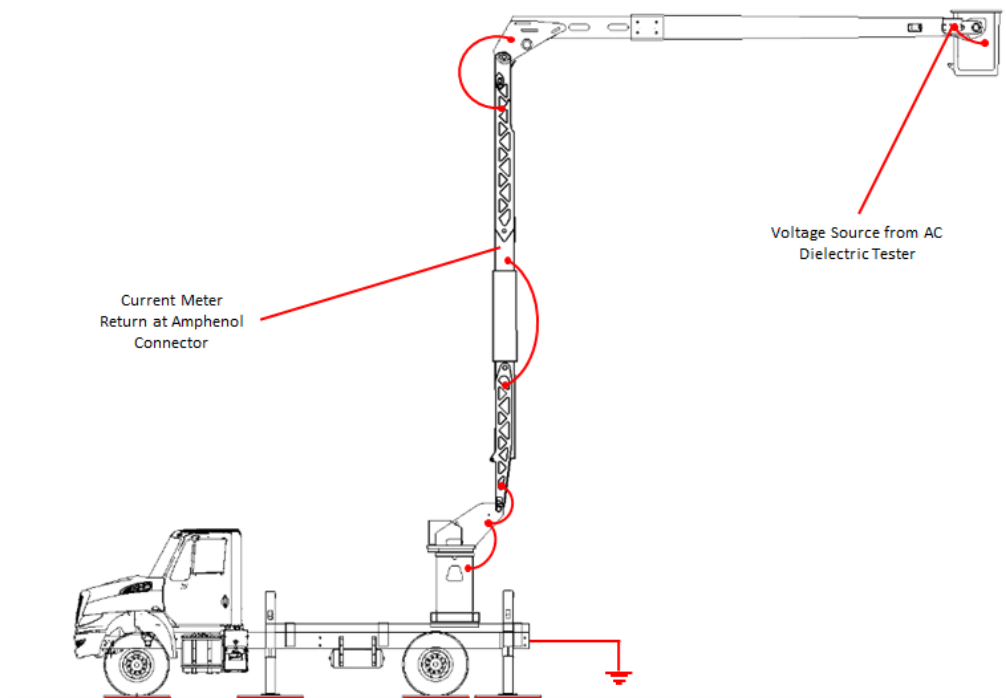

FIGURE 7

STEP 9

Plug in and turn on the dielectric tester. Raise the voltage control to the required voltage listed on the test sheet. Monitor the volt and current meters to verify the test is working correctly. If the current meter reads zero, verify all connections.

If the current meter value stays below the Max Leakage, continue the test until complete, record readings, return the voltage control to 0, turn off and unplug the dielectric machine.

If the current meter value exceeds the Max Leakage at any point during the test, return the voltage control to 0, turn off and unplug the dielectric machine. Begin troubleshooting to determine why the boom will not pass the dielectric test. Reference Tech Tip #51 for further troubleshooting help.

The upper boom Qualification and Periodic readings are shown below. Qualification testing is done on a new unit install or after a major component such as a boom is replaced. Periodic testing is done once a year to verify dielectric integrity of the unit.

For a 69kv Category B AC Qualification test, the reading for Rated Voltage should be no higher than 40 μ A for 1 minutes at 40 kV and Double Rated should be no higher than 80 μ A for 1 minutes at 80 kV.

UNIT QUALIFICATION	TEST TIME	1 MINUTE AC TEST VOLTAGE	
		Rated	Double Rated
VOLTAGE AC	AM PM	40 kv	80 kv
69kv	Start	μ A	μ A
	Finish	μ A	μ A
S/N	Max Leakage	40 μ A	80 μ A

The 10 second Momentary Withstand Voltage Test should be no higher than 120 μ A for 10 Seconds at 120 kV.

UNIT QUALIFICATION	10 Sec. Momentary Withstand Voltage Test (No Flashover Allowed)
VOLTAGE AC	120 kv
69kv	μ A
	μ A
S/N	120 μ A

For a 69kv Category B AC Periodic/Maintenance Test the reading should be no higher than 60 μ A for 1 minute at 60 KV.

69KV	60KV	Start	μ A
		Finish	μ A
		Max. Leakage	60 μ A

μ A=Microamp

STEP 10

Once testing is complete bring the upper and lower booms down to access the jumpers, voltage source and Current Meter Return at the Amphenol connector. Disconnect the voltage source and Current Meter Return at the Amphenol connector from the boom.

STEP 11

- Remove the following jumpers:
- Turntable above rotation to pedestal below rotation (#1)
- Lower boom insert (#3)
- Upper boom to lower boom (#4)
- Platform bracket to boom tip bracket (#5)
- Jib bracket (if equipped) to platform bracket
- Truck chassis to earth ground (#8)

See **Figure 6** to identify jumpers.

STEP 12

To begin setup for testing the lower boom, raise the upper boom up to a 45-degree angle. Raise the lower boom high enough to clear all obstacles and rotate the turntable 180 degrees so that the knuckle is off the back of the unit as shown in **Figure 11**.

STEP 13

Attach the Current Meter Return to the back of the truck as shown in **Figure 11**. If a ground lug or loop is available, attach the return there.

STEP 14

Attach the voltage source from the AC Dielectric Tester to the knuckle side of the lower boom and install jumpers between components in the following locations as shown in Figure 11 below:

- Turntable above rotation to pedestal below rotation (#1)

Visually check that all jumpers, voltage source from the dielectric tester and the Current Meter Return are still connected once the unit is in position.

STEP 15

Plug in and turn on the dielectric tester. Raise the voltage control to the required voltage listed on the test sheet. Monitor the volt and current meters to verify that the test is working correctly.

If the current meter value stays below the Max Leakage continue test until complete, record readings, return the voltage control to 0, turn off and unplug the dielectric machine.

If the current meter value exceeds the Max Leakage at any point during the test return the voltage control to 0, turn off and unplug the dielectric machine. Begin troubleshooting to determine why the boom will not pass the dielectric test. Reference **Tech Tip #51** for further troubleshooting help.

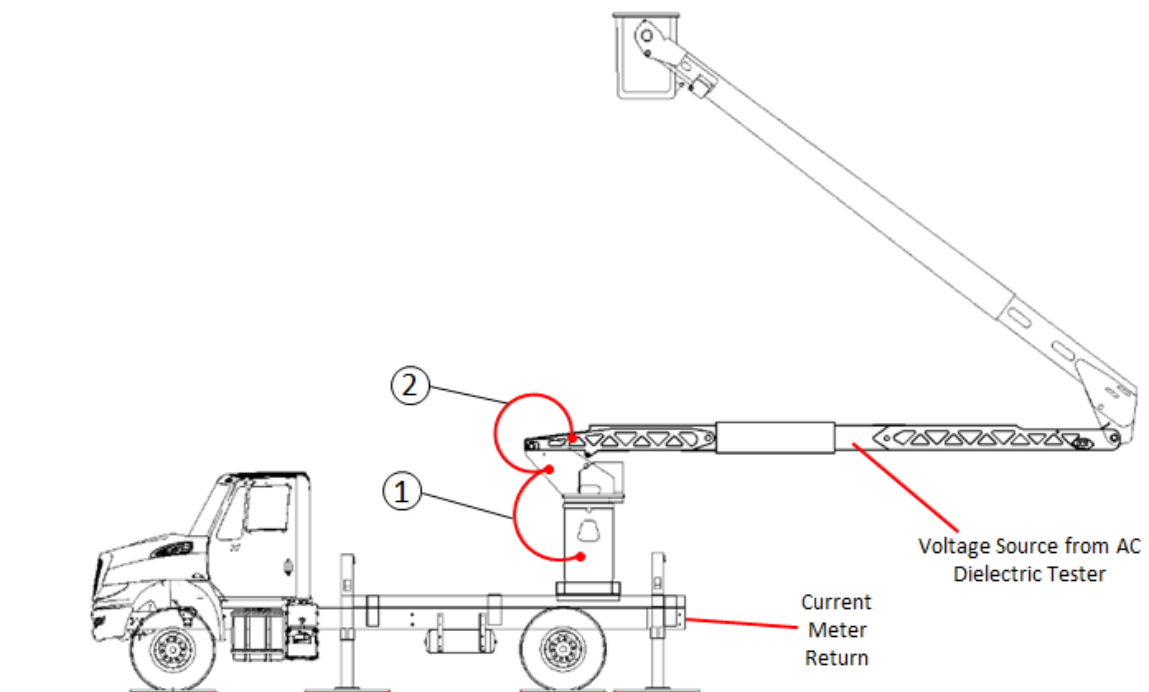

FIGURE 11

STEP 15 (Continued)

The lower boom Qualification and Periodic readings are shown below.

For a Chassis Insulating System (Lower Boom Insert) Qualification test, the reading should be no higher than 3000 μA for 3 minutes at 50 kV.

			TEST TIME	3 MINUTE AC TEST VOLTAGE
			AM PM	50 kv
			Start	μA
			Finish	μA
S/N _____			Max Leakage	3000 μA

For a Chassis Insulating System (Lower Boom Insert) Periodic/Maintenance test the reading should be no higher than 3000 μA for 1 minute at 35 kV.

AC TEST - 1 Minute		
TEST VOLTAGE	Time	Leakage
35 KV	Start	μA
	Finish	μA
	Max. Leakage	3000 μA

μA =Microamp

STEP 16

Once testing is complete disconnect the voltage source from the boom.

Remove all the jumpers from the following locations indicated in **Figure 11**:

- Turntable above rotation to pedestal below rotation (#1)
- Turntable above rotation to lower boom (#2)

Remove the Current Meter Return from the back of the truck.

STEP 17

To begin setup for testing the upper control handle, bring the platform to the ground mount position at the back of the truck.

STEP 18

Attach the voltage source from the AC Dielectric Tester to the control handle using a spring with the cable going over the top of the platform as shown below.



STEP 19

Reach under the upper control cover and attach the current meter return to a fitting that is attached to the upper control valve as shown below. (Cover removed for clarity)



STEP 20

Elevate the platform to at least 4 feet above the ground. Visually check that all jumpers, the voltage source from the dielectric tester, and the return are still connected once the unit is in position.

STEP 21

Plug in and turn on the dielectric tester. Raise the voltage control to the required voltage listed on the test sheet. Monitor the volt and current meters to verify that the test is working correctly.

If the current meter value stays below the Max Leakage continue the test until it is complete, record readings, return the voltage control to 0, turn off and unplug the dielectric machine.

If the current meter value exceeds the Max Leakage at any point during the test, return the voltage control to 0, turn off and unplug the dielectric machine. Begin troubleshooting to determine why the single stick control handle will not pass the dielectric test.

STEP 21 (Continued)

The Single Stick Qualification and Periodic readings are shown below.

For a Single Stick Control AC Qualification and Periodic/ Maintenance test the reading should be no higher than 400 μA for 3 minutes at 40 kV.

Test time: AM / PM 3 minutes		AC test (40KVAC)	Leakage
Start			μA
Finish			μA
		Allowable	400 μA

μA =Microamp

STEP 22

Once testing is complete lower the platform to the ground mount position. Remove the spring from the control handle and current meter return from the upper control valve fitting.

STEP 23

Store the unit and raise the outriggers. Remove any barriers around the unit and drive the unit off the pads and out of the dielectric test area.



FOR FURTHER ASSISTANCE,
CONTACT THE TEREX UTILITIES TECHNICAL SUPPORT TEAM
PHONE: **1-844-TEREX4U (1-844-837-3948)** | EMAIL: **UTILITIES.SERVICE@TEREX.COM**
