

# CEDARAPIDS®

A TEREX BRAND

## MVPX Series Cone Crushers



A world working better™

 **TEREX**® MPS

# Contents

- 01 Introduction - Designed to Deliver
- 02 Crushing the Competition
- 03 Proven Capabilities
- 04 Operating Time, Not Downtime
- 06 Advantages/Key Features
- 07 Walkround
- 08 Cedarapids® Services

## Cedarapids®

# Designed to Deliver. Built to Last.

Cedarapids® understands your business and we are dedicated to offering cost-effective solutions for your needs.

In today's competitive environment, you need to have high quality equipment. It's even better to know that your equipment is backed by an outstanding support network.

Customer satisfaction is our goal. Our service, parts, applications and sales teams are trained to provide our customers with crushing and screening process knowledge and fast friendly service. With over eight decades of experience and our leading edge technology, you can depend on us.

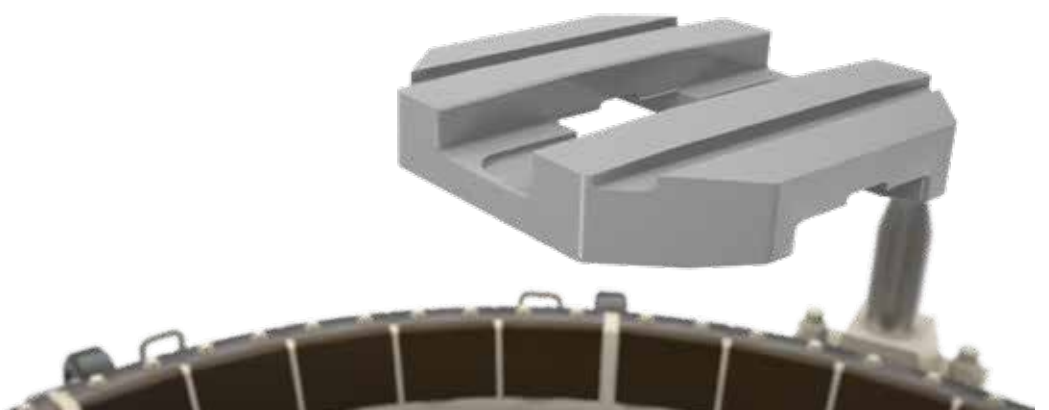

# MVPX Series Cone Crushers

## Crush the Competition

Cedarapids® MVPX Crushers conquer challenges

You wrestle with multiple challenges every day in the aggregates business: cutting costs, becoming more productive, meeting customer requirements, staying competitive. The Cedarapids® MVPX cone crusher is an industry leader that simply pulverizes everything that stands in the way of success.

The advanced engineering of the MVPX features the ElJay® roller bearing design and a hydropneumatic tramp iron relief system that revolutionized the industry. The complete MVPX line includes three different models in stationary or portable configurations, from 300 to 500 hp, processing up to 810 tons per hour and capable of handling sand and gravel, shot rock and recycled materials. Each machine offers you an array of competitive advantages—from improved product quality, to higher throughput capacities, to lower operational costs.

Cedarapids® MVPX—the leading force in compression crushers.

## Built To Deliver

### Tons of Advantages

It all comes down to delivering more tons of material cost effectively.

Cedarapids® MVPX crushers make it no contest. They weigh in with sheer power, innovative technologies and time-tested reliability. Their performance gives you a low cost-per-ton. You are able to meet the requirements of your customers for superior quality product.

You are able to meet the needs of your business with a cost effective crusher — the MVPX. Put it to work for you.

## Versatility and Value

Every detail of the Cedarapids® MVPX has been designed to provide superior performance. As a result, it offers high versatility and high value.

- High net tons of finished product per operating hour
- Ability to adjust under load means more up time, resulting in more production
- Ability to make Superpave materials
- Ability to operate in a true choke feed condition
- Ability to operate at tight settings

### Proven Capabilities

Whether it's a matter of capacity, quality, yield or efficiency, the Cedarapids® MVPX will take you to high levels of performance. The unique ElJay® Rollercone® design, famous for its efficiency, has proven itself for decades and with each succeeding generation the MVPX has advanced the technology.

### Increase Your Crushing Power

Imagine crushing more product on the first pass. That's the efficiency of the MVPX's proven rotating wedge plate design. It transmits a very high percentage of the input energy to direct crushing power. Riding the wedge plate with an eccentric motion, the cone head squeezes rock between the mantle and stationary bowl liner. Rock is crushed on the closed-side setting, and simultaneously discharged on the open-side setting.

The wedge plate's roller bearings also contribute to improved productivity. Their tight tolerances reduce oversize to about 15% to 20% instead of the 30%+ typical for bronze-bushing cones when making 1/2" (12.7mm) minus product. This allows more feed material in the circuit with less recirculation. The Cedarapids® MVPX offers power, capacity, quality and ultimately, profitability.

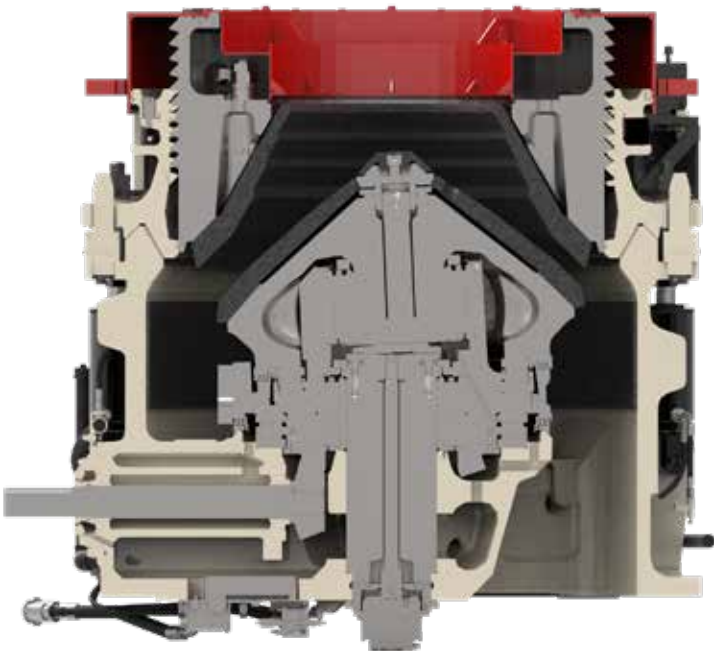

# Cedarapids®

## Operating Time, Not Downtime

The very technologies that make the Cedarapids® MVPX so highly productive also help prevent downtime. The frictionless roller bearing generates less heat and provides extensive service life. An anti-spin mechanism prevents spinning of the cone head when empty, thus reducing excess wear on the cone liners.

A heavy-duty cast base frame withstands the harshest applications to prolong the unit's service life.

Replaceable counterweights maintain vibration-free performance.

Hydropneumatic tramp iron relief system safely passes uncrushable materials. Every aspect of the MVPX design was engineered to provide reliable operation day after day.

### High Capacity

- Unrestricted, full sized feed entry easily handles large slabs
- Advanced head and chamber design minimizes hang-ups
- Roller bearing provides superior load carrying capacity

### High Quality

- Head angle and crushing chamber design enhances cubical product
- Remote, on-the-fly adjustment for fine tuning of output gradations
- Advanced automated cone control system standard.

### High Yield

- Varying speeds and crushing chamber configurations produce more product, less waste
- High hold down pressure and optimum speed deliver greatest saleable product
- Electronic bowl float monitoring system standard, for added reliability and cone protection.

### High Efficiency

- Field-proven ElJay® Rollercone® roller bearing design converts high percentage of horsepower into crushing power
- More product produced per hour with less friction and heat
- Long crushing chamber with high retention results in more crush per pass



# MVPX Series Cone Crushers

## Advantages/Key Features

- New ACE8 Advanced Automated Cone Control System helps improve the crusher's performance as well as overall reliability, including a bowl float monitoring system as standard.
- Fully guided dual action tramp relief cylinders provide 6" (152 mm) lift for easy clearing of jammed feed material to reduce downtime and increase productivity.
- Hydraulic powered threaded upper assembly for quick crusher setting adjustment under load.
- Hydro-pneumatic tramp iron relief system instantly resets crusher setting after passing uncrushable material; high flow manifold system with multiple accumulators provides redundant cylinder protection.
- Pinned cylinder ends remove quickly to allow fast cone separation for fast manganese changes, reducing downtime.
- Optional counterweight wear guard eliminates high velocity wear on base frame and weights, reducing maintenance (MVP380X & MVP450X models)
- Computer optimized, high endurance, all-cast construction with new upper and lower frame castings; rugged, field proven cone head and bowl nut castings for high-force, demanding crushing applications.
- Patented Rollercone® design and super bearing increase efficiency, making more horsepower available for crushing.
- Full size feed entry and a vigorous upper cone crushing action increase throughput.
- Anti-spin brake stops the cone head from spinning, preventing wear on the liners which increases manganese life.





# MVPX Series Cone Crushers

Clamp cylinders hold setting securely during crushing but also allow for adjustment under load

Full size feed opening with active upper head to better handle slabby feed

Tramp iron relief system for consistent passing of uncrushables

One-way clutch prevents head from spinning with empty chamber

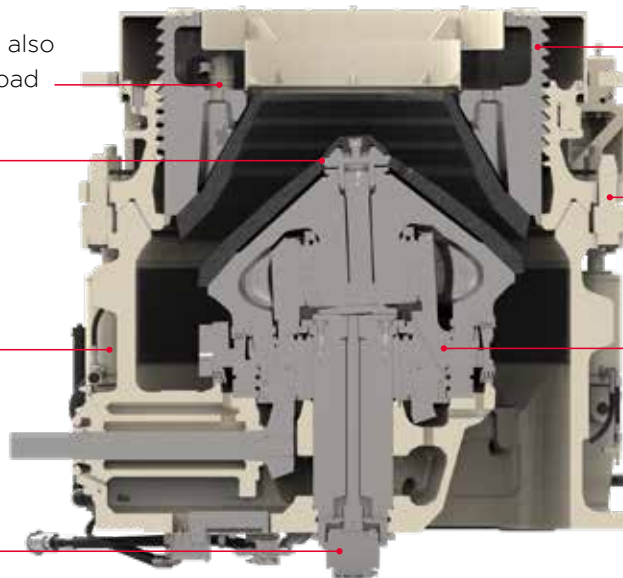

Bowl assembly with easy-change liner and brass thread inserts for trouble-free adjustments under load

Hydraulic adjusting motor assembly for fast, safe operation

Wedge plate with roller bearings to distribute load 360 degrees around bearing

## Cedarapids® Services

### Proven Success, Global Reach

A comprehensive range of services. Original spare and wear parts. Customizable solutions to meet your exact needs. Outstanding technical expertise and support.

This is what Cedarapids® delivers to businesses – and what it delivers to businesses throughout the world via our global distribution network, service and distribution facilities and regional warehouses.

### Spare and Wear Part Support

Our OEM parts help maintain and enhance the performance of your equipment – and you can count on us to get you the spare and wear parts you need, when you need them.

Cedarapids® parts are manufactured according to exact specifications, using high-quality materials, tools and techniques. By using genuine parts you are helping to ensure the maximum performance and longevity of your machines.

### A Shared Focus

We understand your key focus is delivering your operational and financial goals. We share that focus: it's how we both measure success.

By combining our global service network and proven, in-depth industry knowledge with your operational expertise we're able to provide you with the right solution to deliver a quality end product – with increased productivity.

### Field Services

We offer a comprehensive set of field services to meet your maintenance, repair and refurbishment needs – which means you get a cost-effective alternative to purchasing new or replacement equipment.

Our experienced field service and distribution network are available to you on site or at our global service facilities. We can repair broken or damaged equipment to like-new condition and restore worn or irreplaceable equipment to perfect operating condition – which minimizes costly downtime for you.

Combining our global service network and deep industry knowledge with your operational expertise ensures that we provide the best solutions...



## Terex® Financial Services

At Cedarapids® we not only offer a strong and broad product portfolio. We also offer the means for customers to purchase the equipment they need in order to meet their operational and profitability goals.

Terex® Financial Services is a globally trusted resource that is able to leverage its knowledge of Terex® equipment plus its marketplace expertise to provide a unique tailored solution for customers.

### Terex® Financial Services at a Glance

- Providing cost-effective financial solutions to thousands of customers across the globe
- A comprehensive suite of financial solutions tailored to fit individual needs
- Dedicated and knowledgeable team with global reach, focused on customer solutions.

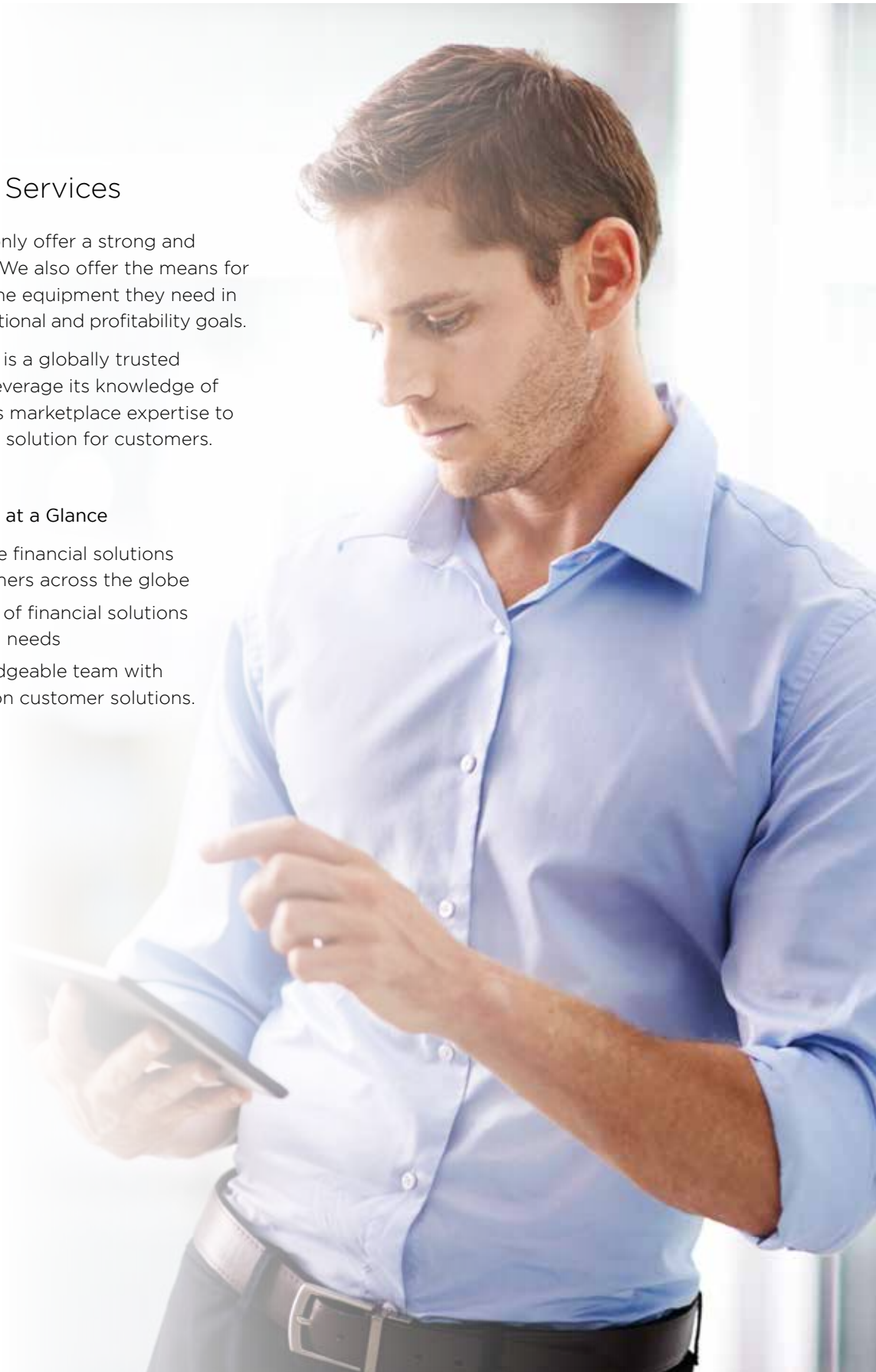

**North America**

3900 Fountains Blvd NE, Suite 101  
Cedar Rapids, IA 52411  
Tel: +1 319 363 3511 or +1 800 821 5600  
Fax: +1 319 399 4871

212 South Oak Street  
Durand, MI 48429  
Tel: +1 989 288 3121  
Fax: +1 989 288 4113

**Europe, Russia & Africa**

Farlough Road, Dungannon  
Northern Ireland. BT71 4DT  
Tel: +44 (0) 28 8744 0795

**Central Asia, Turkey & North Africa Region**

Mehmet Akif Ersoy Mah.287.SkNo 1/D  
06172 Yenimahalle - Ankara Turkey  
Tel: +90 312 354 90 90

**Australia**

**Melbourne & Victoria**  
133 Logis Boulevard  
Dandenong South, VIC 3175  
Tel: +61 3 8794 4100  
Fax: +61 3 9706 7810

**Sydney & New South Wales**

114 Hassall Street  
Wetherill Park, NSW 2164  
Tel: +61 2 9604 6524  
Fax: +61 2 9604 9368

**Brisbane & Queensland**

585 Curtin Avenue East  
Eagle Farm, QLD 4009  
Tel: +61 7 3630 0866  
Fax: +61 7 3630 1097

**Perth & Western Australia**

4 Miles Road  
Kewdale, WA 6105  
Tel: +61 8 6254 4100  
Fax: +61 8 9350 5534

**India****South :- Hosur Plant**

Terex India Private Limited  
E-18, Phase II, Expansion II,  
Sipcot Industrial Complex  
Hosur, Tamil Nadu 635109  
Tel: + 91 4344 302 200  
Fax: + 91 4344 302 201

**North**

Terex India Private Limited  
907-908 9th Floor, Palm Spring Plaza,  
Golf Course Road  
DLF Phase 5, Sector 54, Gurugram - 122011 India

**East**

Terex India Private Limited  
5th Floor Swastik Building  
Nazrul Islam Avenue  
Tegharia, Kolkata  
West Bengal- 700059

**West**

Terex India Private Limited  
5-129 5th Floor  
Zenia Building, Hiranandani Circle  
Hiranandani Business Park, Off Ghodbunder Road,  
Thane Mumbai MH 400607

**UAE****Middle East, East Africa, and SE Asia**

Office # 305, Pinnacle Building  
Sheikh Zayed Road, Al Barsha 1, Dubai, UAE  
Tel: +971 4 399 0381  
Fax : +971 4 399 0382

**Malaysia**

Subang Jaya, Selangor, Malaysia  
Contact: Mr. Benjamin Tong  
Tel: +60(3) 5622 6103 or +60(3) 5622 6199  
Fax : +60(3) 5631 6211

**Thailand**

777/1, Moo 7, Bangplee-Tumru Road,  
Bangpleeyai, Bangplee, Samutprakarn,  
10540, Thailand  
Tel: +66 2 316 4656 or +66 2 316 4658  
Fax: +66 2 316 4660

[www.terexmps.com](http://www.terexmps.com)  
[mpsmarketing@terex.com](mailto:mpsmarketing@terex.com)

Product specifications and prices are subject to change without notice or obligation. The photographs and/or drawings in this document are for illustrative purposes only. Refer to the appropriate Operator's Manual for instructions on the proper use of this equipment.

Failure to follow the appropriate Operator's Manual when using our equipment or failure to act responsibly may result in serious injury or death.

The only warranty applicable to our equipment is the standard written warranty applicable to the particular product and sale, and Terex makes no other warranty, express or implied. Terex, the Terex Crown design, Cedarapids, Canica, Simplicity, Jaques, El-Jay and Rollercone are trademarks of Terex Corporation or its subsidiaries. All rights are reserved. ©August 2019

