

CEDARAPIDS

A TEREX BRAND

Portable Closed
Circuit
Impactor/Screen
Plant

CRH1111R

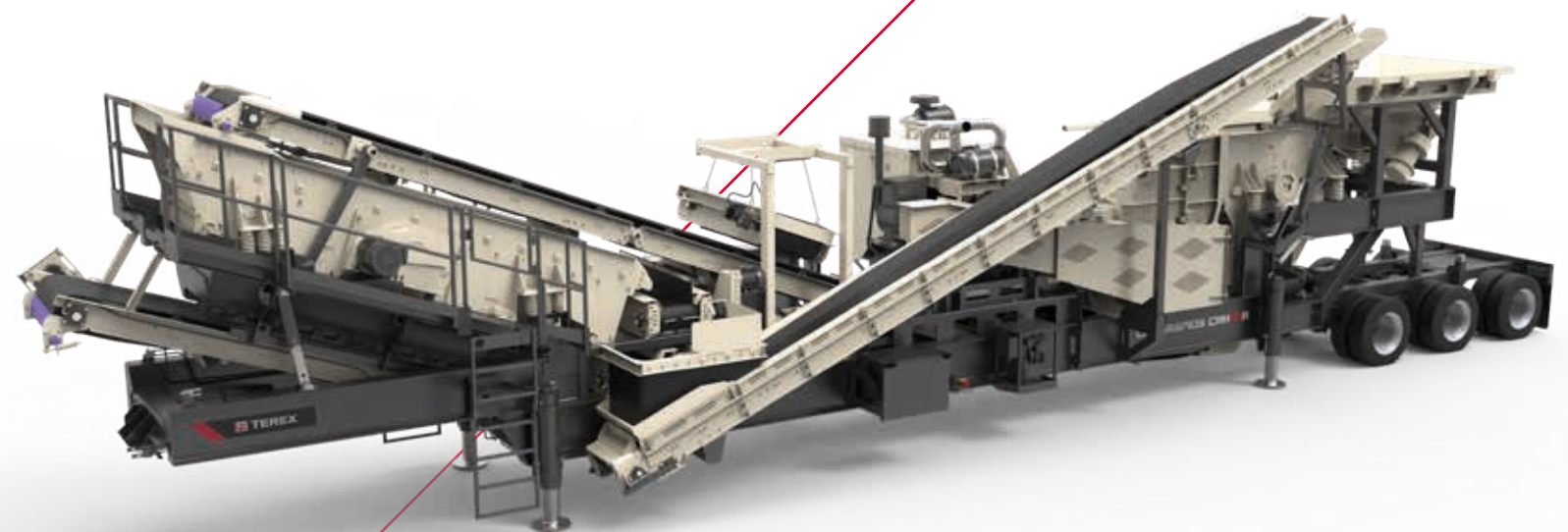

A world working better™

 **TEREX**® MPS

Cedarapids® Portable Plants

CRH1111R Closed Circuit Cone/ Screen Plant

Exceptional Productivity & Efficiency

The CRH1111R Portable Closed Circuit Cone/Screen Plant features the T14143 impact crusher and a 5x16 2-deck inclined screen. The crusher is hydraulic clutch driven direct from a 350hp Scania diesel. All other components are electric driven from the 150kw generator. With its large screen, wide conveyors, and low maintenance electric driven components, this is a highly productive, high value plant.

Standard Features

- T14143 impact crusher
- 5x16 2-deck screen
- 350HP T4 Scania Diesel with hydraulic clutch crusher/generator drive
- 150kw generator
- 42.5" x 14.3' vibrating grizzly feeder with 7' stepped 2-deck grizzly
- 24" reversible conveyors can feed both screen decks to return conveyor
- Gas powered hydraulic leveling jacks & screen lift
- Removable CCM automatic switchgear panel
- Travel; 11'-10" wide, 13'-5" tall, 3-axle suspension

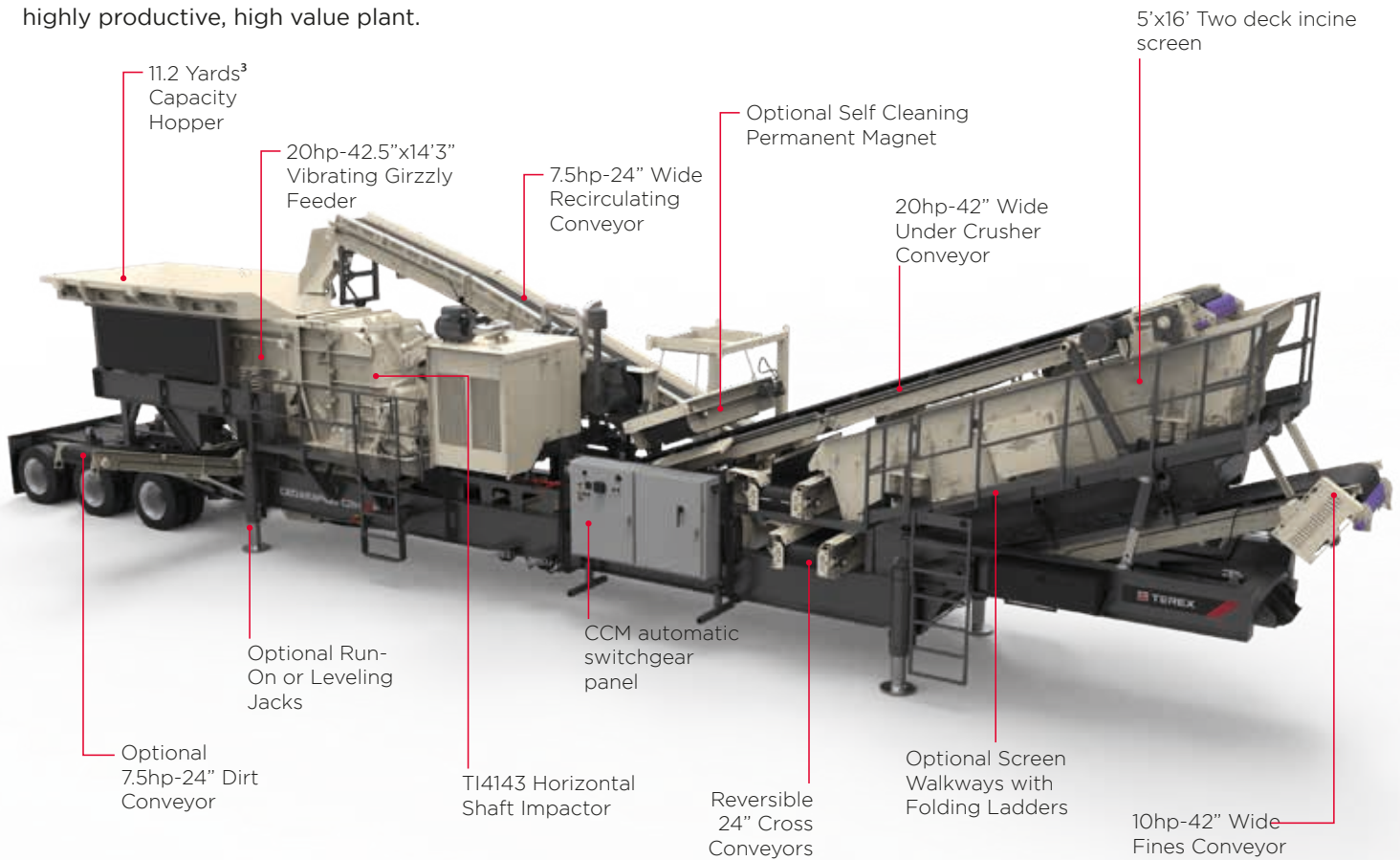

Optional Equipment

- Off-plant starters & radio remote
- Screen side platforms & ladder
- Dual pinned hydraulic run-on jacks
- Economical self-cleaning cross belt permanent magnet mid plant
- Folding grizzly reject conveyor with 6' discharge
- Various grizzly options for bar spacing, punch plate, & 2nd deck wire
- Pan feeder/pre-screen in place of vibrating grizzly feeder
- All electric (no diesel)



Base plant with Vibrating Grizzly Feeder



Optional Pre-Screen with Pan Feeder

Working Dimensions

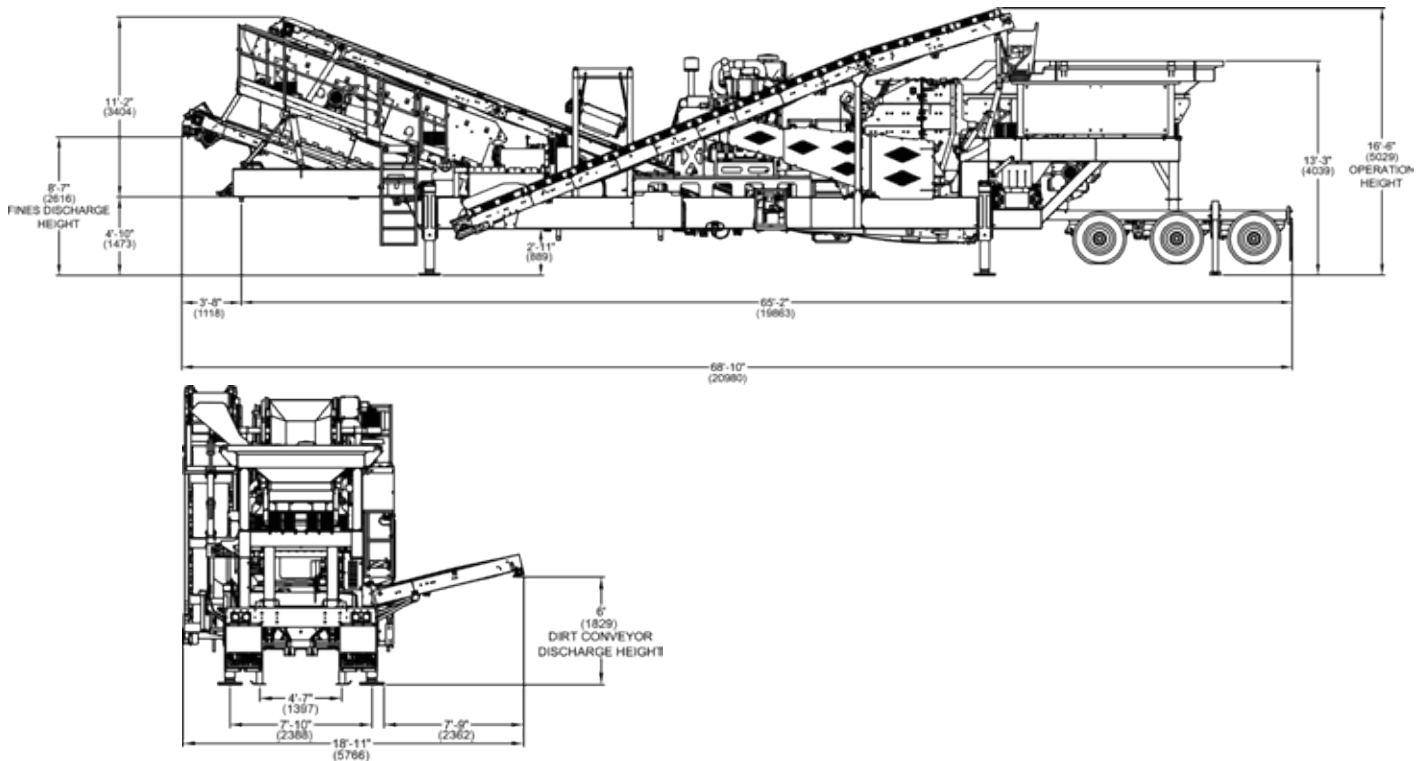

Transport Dimensions

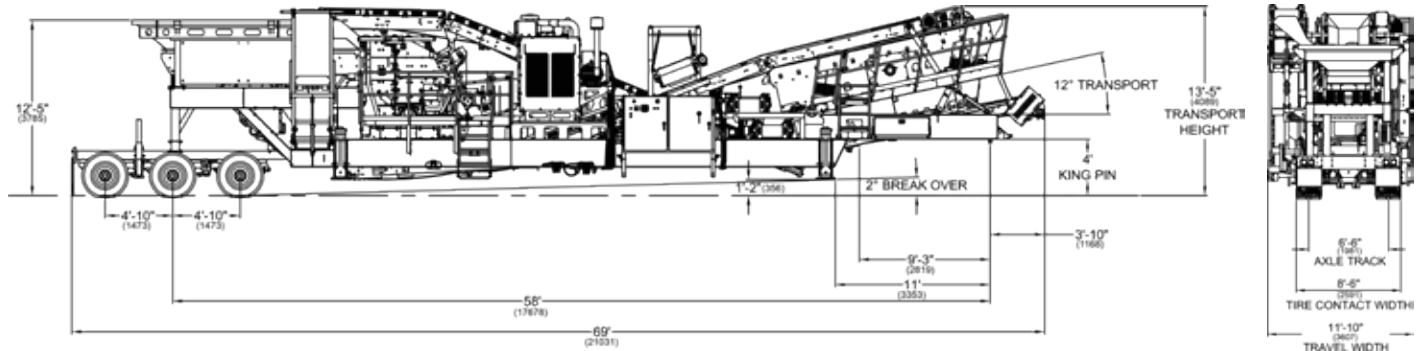

Total Weights

	Kingpin Weights	Axle Weights
Base Plant	39,958 lbs (18,125 kg)	54,048 lbs (24,516 kg)
+Dirt Conveyor	+467 lbs (212 kg)	+2,128 lbs (965 kg)
+Leveling Jacks	+313 lbs (142 kg)	+310 lbs (141 kg)
+Run On Jacks	+1,085 lbs (492kg)	+1,075 lbs (488 kg)
+Screen Base Walkways	+962 lbs (436 kg)	+123 lbs (56 kg)
+Magnet	+2,337 lbs (1,060 kg)	+1,465 lbs (666 kg)

North America

3900 Fountains Blvd. NE
Suite 101
Cedar Rapids, IA 52411
Tel: +1 319 363 3511 or +1 800 821 5600
Fax: +1 319 399 4871

212 South Oak Street
Durand, MI 48429
Tel: +1 989 288 3121 or +1 888 571 8352
Fax: +1 989 288 4113

Europe, Russia & Africa

32 Farlough Road, Dungannon,
County Tyrone, Belfast BT71 4DR
Tel: +44 (0) 28 8744 0795

Central Asia, Turkey & North Africa Region

Mehmet Akif Ersoy Mah.287.SkNo 1/D
06172 Yenimahalle - Ankara Turkey
Tel: +90 312 354 90 90

Australia

Melbourne & Victoria
133 Logis Boulevard
Dandenong South, VIC 3175
Tel: +61 3 8794 4100
Fax: +61 3 9706 7810

Sydney & New South Wales
114 Hassall Street
Wetherill Park, NSW 2164
Tel: +61 2 9604 6524
Fax: +61 2 9604 9368

Brisbane & Queensland
585 Curtin Avenue East
Eagle Farm, QLD 4009
Tel: +61 7 3630 0866
Fax: +61 7 3630 1097

Perth & Western Australia
4 Miles Road
Kewdale, WA 6105
Tel: +61 8 6254 4100
Fax: +61 8 9350 5534

www.terexmps.com

March 2018. Product specifications and prices are subject to change without notice or obligation. The photographs and/or drawings in this document are for illustrative purposes only. Refer to the appropriate Operator's Manual for instructions on the proper use of this equipment.

Failure to follow the appropriate Operator's Manual when using our equipment or failure to act responsibly may result in serious injury or death.

The only warranty applicable to our equipment is the standard written warranty applicable to the particular product and sale, and Terex makes no other warranty, express or implied. Terex, the Terex Crown design, Cedarapids, Canica, Simplicity, Jaques, El-Jay and Rollercone are trademarks of Terex Corporation or its subsidiaries. All rights are reserved. © 2018

