



# Modular Plants MHS6203 Screen Module



# Simplicity<sup>®</sup> Modular Plants

## MHS6203 Screen Module

The MHS6203 modular screen features the extremely efficient 6' x 20' horizontal screen with its legendary ElJay<sup>®</sup> oval stroke action. Set-up time and ease of operation is aided by the simplicity of the modular product range. All of our modular crushers and modular screens bolt together on site and require minimal on-site wiring. Designed with logistics in mind, the MHS6203 module ships in two 40' shipping containers plus the screen.

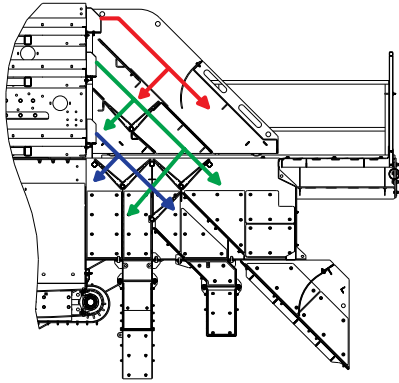

### Standard Features

#### Module Structure

- Bolts together on site, quick set-up time with basic tools
- Minimal on-site wiring
- Robust weather-protected control panel with user-friendly controls
- Galvanized steel structure including walkways, stairs and guard rails
- Extra-heavy-duty I-beam frame with rigid diagonal truss construction
- Integrated rolling chute mechanism and integrated trouser leg chutes
- CE compliant module structure and components
- Systematically packed in shipping containers for quick site setup and easy transport

#### Blending Chutes

- 4-section (25%) blending gate system for all decks
- 2-section (25%) blending gates for bottom deck
- Deck product combinations: top-center; center-bottom; bottom-fines; center up to top; bottom up to center
- Heavy-duty AR 400 liners on impact surfaces
- Flop gates are made from AR 400 steel

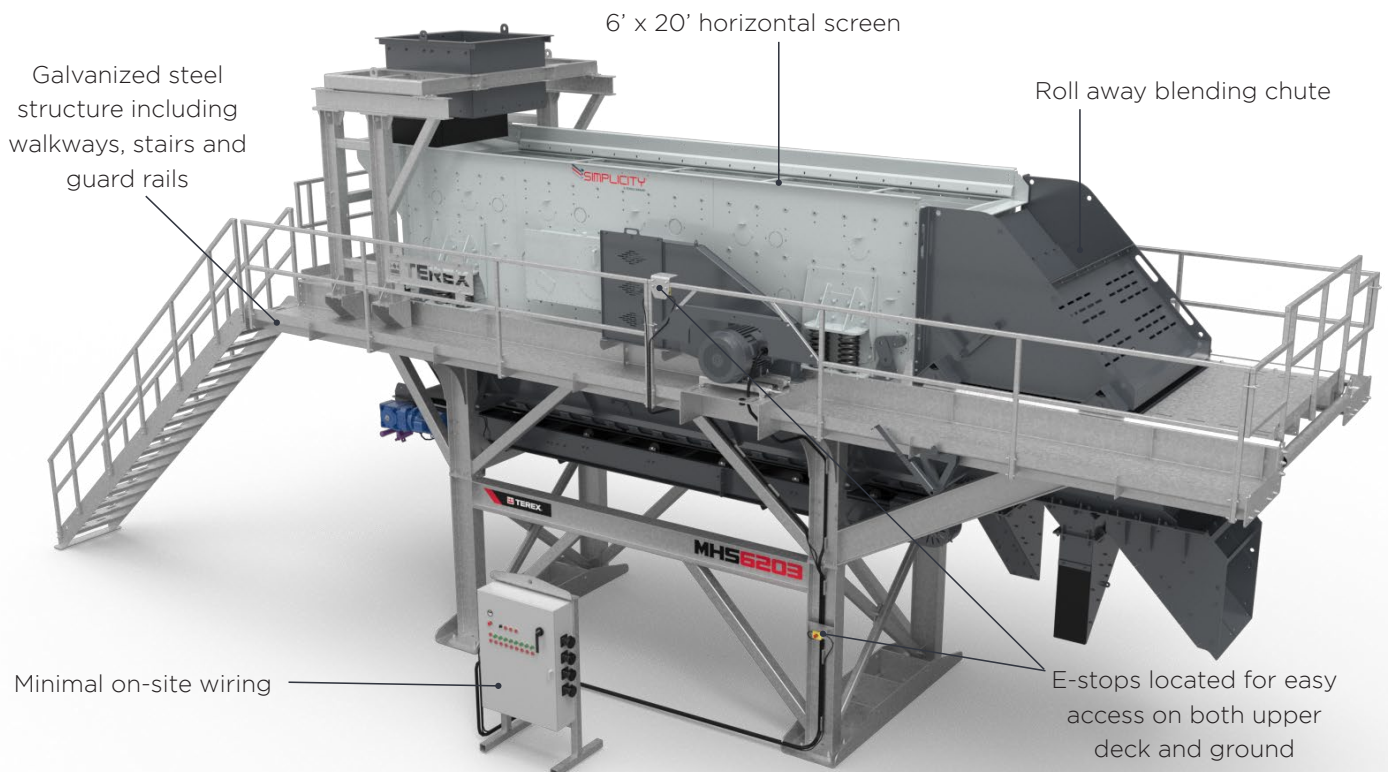

\*Shown with optional electrical switchgear panel and mounting feet

### Horizontal Screen

- 6' x 20' (1828mm x 6096mm) 3-deck horizontal screen with El-Jay™ oval stroke design
- Three-shaft vibrator mechanism with adjustable stroke angle, stroke length, and speed
- 25% thicker 5/16" (8 mm) grade 50 high strength steel side plates
- Heavy-duty fully braced single crown steel deck construction
- Exclusive patented and patent-pending features for durability and easy maintenance:
  - Low maintenance vibration damper system
  - "Flow-through" bearing lubrication
  - Baffle splash lubrication system
  - Double O-ring sealed for life vibrator construction
- Spherical washer design eliminates sidewall welds
- Huck-bolted screen box construction (no welds)
- Extended life coil spring suspension
- Replaceable bolt-on spring guides
- Gland type non-wearing shaft seal
- Tool-less oil level sight glasses

### Underscreen Conveyor

- 36" (900mm) fully skirted underscreen fines conveyor
- 10 hp (7.5kW) electric motor, vulcanized 2-ply belt
- Direct drive motor and gearbox
- Easy access belt take-ups
- High performance belt wiper

Specifications	Imperial	Metric
Screen Size	6' x 20'	1828 x 6096 mm
Screen Motor	40 hp	30 kW
Underscreen Conveyor Width	36"	900 mm
Underscreen Conveyor Motor	10 hp	7.5 kW
Estimated Module Weight	48,500 lbs	22,000 kg

### Power Panel

- Electric power panel for screen and on-plant collection conveyor

### Optional equipment

- Mounting feet for easy setup at site without concrete pads (full length skid bases also available)
- Electrical switchgear panel
- Off module conveyor starter kit for off-plant feed conveyor and four off-plant product conveyors
- Feed Box and Support Structure for Dry Screening - Rock Box Style material feed box allows for the conveyor to feed from either side or over the back of the screen
- Wash Plant Option - Feed Box with two spray bars and support structure, screen spray system with manifold and under screen flume

### Working Dimensions

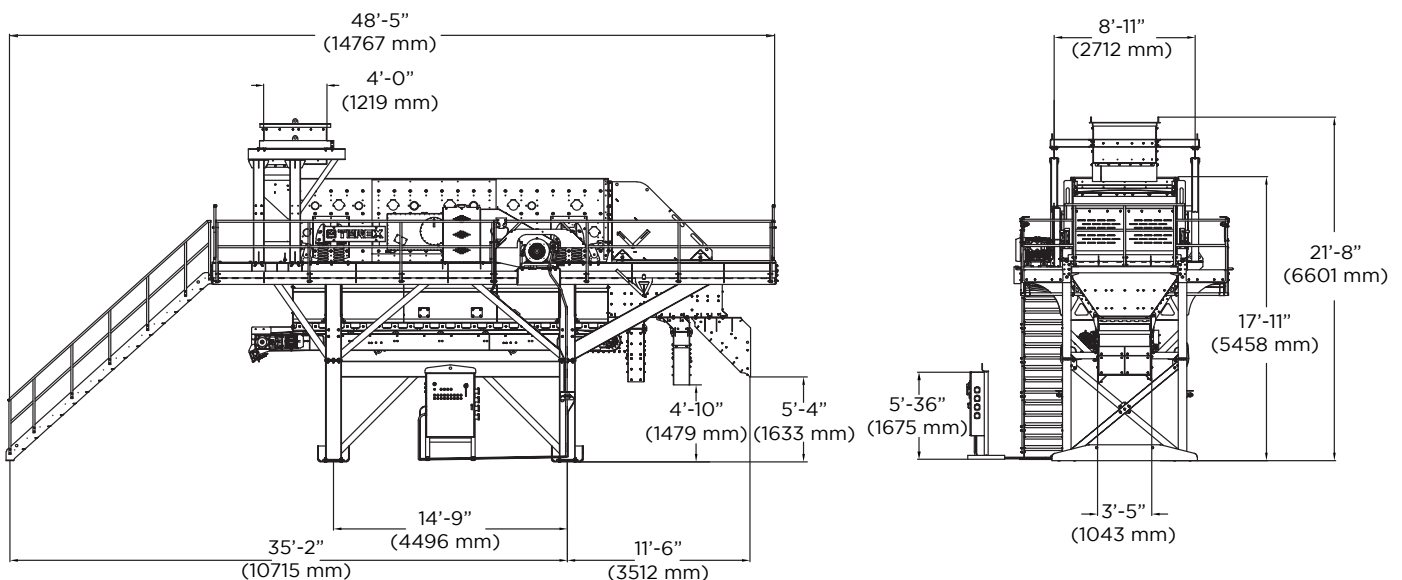

Shown with optional switchgear, mounting feet and feed box.

Working Dimensions - Wash Option

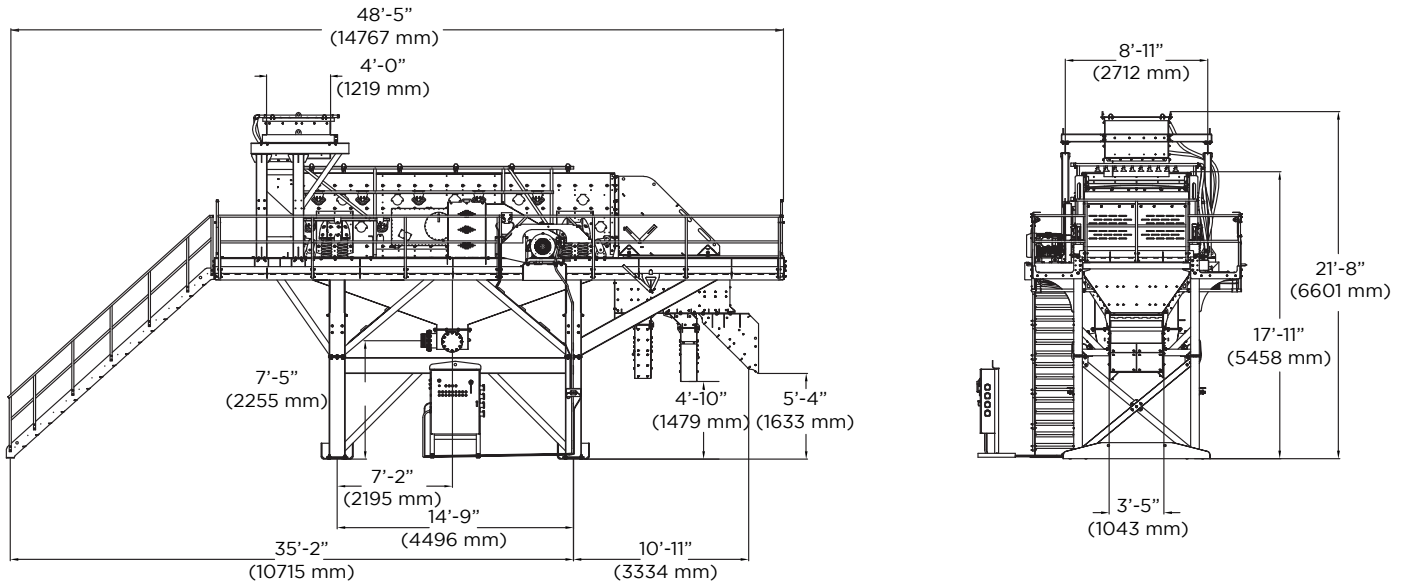

Shown with optional switchgear and mounting feet.

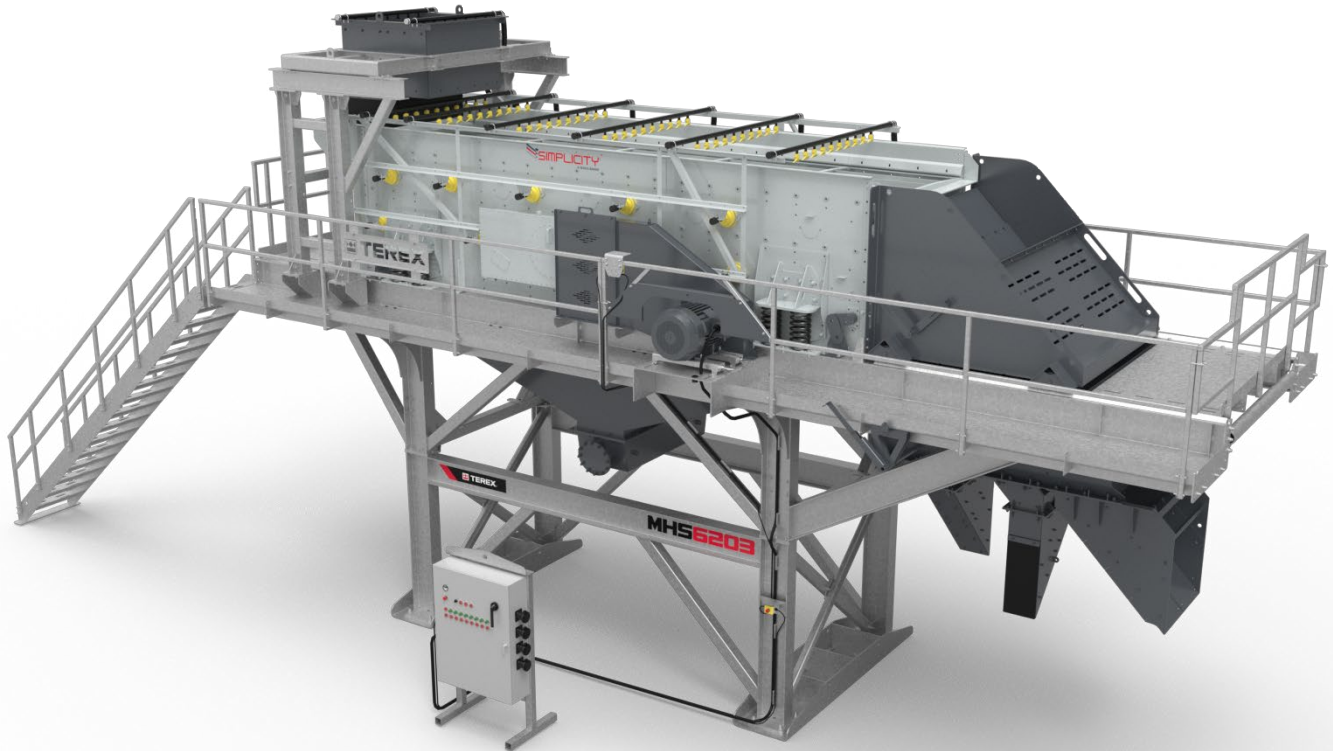

[www.terexmps.com](http://www.terexmps.com)

Product specifications and prices are subject to change without notice or obligation. The photographs and/or drawings in this document are for illustrative purposes only. Refer to the appropriate Operator's Manual for instructions on the proper use of this equipment.

Failure to follow the appropriate Operator's Manual when using our equipment or failure to act responsibly may result in serious injury or death.

The only warranty applicable to our equipment is the standard written warranty applicable to the particular product and sale, and Terex makes no other warranty, express or implied. Terex, the Terex Crown design, Cedarapids, Canica, Simplicity, Jaques, El-Jay and Rollercone are trademarks of Terex Corporation or its subsidiaries. All rights are reserved. © May 2021