

Cedarapids®

A TEREX BRAND **SINCE 1923**

Horizontal Screens TSV Series

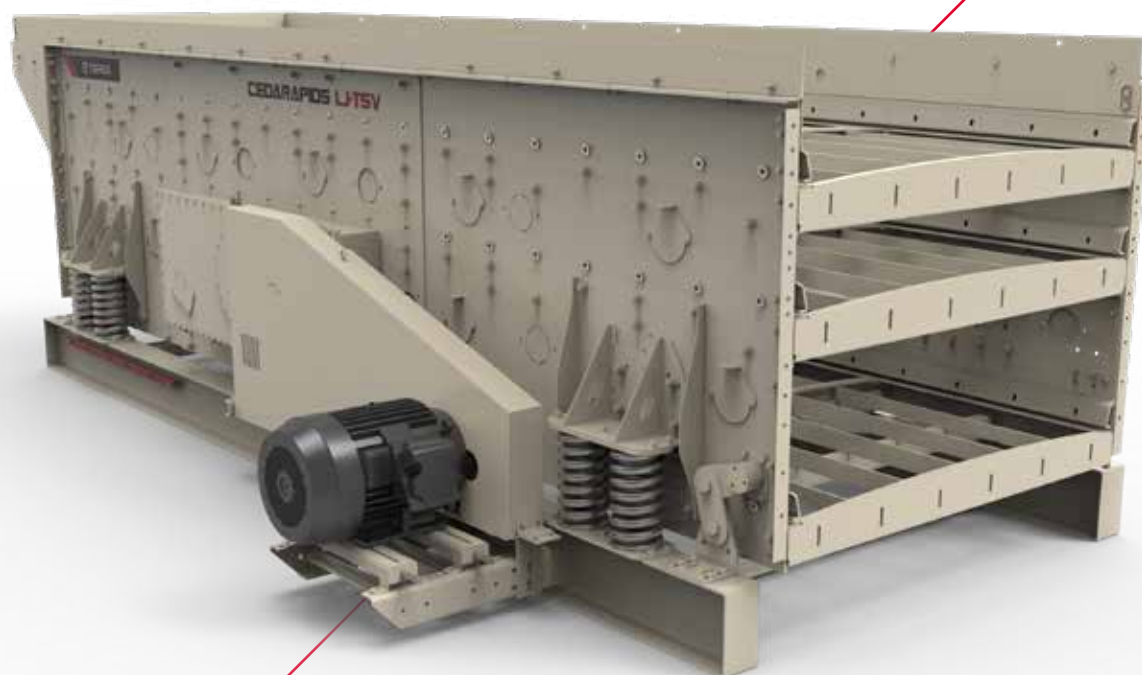

A world working better™

 **TEREX** MPS

Cedarapids® TSV Series

The Cedarapids TSV series screens take the legendary oval stroke screen to the next generation of product. These TSV series screens are built stronger, run smoother, handle more applications, and have longer life than older or copycat oval stroke screens in the market today.

Designed for Long Life

- More steel in “rock zone” for industry leading durability; 5/16” (8 mm) Grade 50 side plates are 2-times stronger than 1/4” (6 mm) standard steel; rugged computer-optimized decks with full-length bracing are unmatched
- Patented gear case baffled lubrication system along with high tolerance machined eccentric weights provide smooth running and long bearing life
- Longer HD suspension springs handle heavier loads and improve isolation to protect the screen and support structure from shock and vibration
- Patented Dual O-Ring Huck Bolt construction is “sealed for life” requiring no re-tightening or maintenance

More Production

- Enhanced Action on the Feed end provides improved screening in the heavy load zone
- Variable slope installation from zero to 10 degrees allows matching the slope to the application to minimize bed depth as well as larger screen openings up to 6”
- High G-force, high efficiency oval stroke motion adjusts 3-ways (speed, stroke angle, stroke magnitude) to optimize performance
- Patented optional bottom deck deflector plates boost screen efficiency by up to 12%
- Medium scalper option increases feed size from 10” to 14” (254 to 355 mm); option includes side liners/ with 6” side extensions to contain larger stones
- High Speed Variable slope (HSV) option increases operating speed up to 1000 rpm with reduced stroke compared to standard screen

Reduced Cost of Ownership

- Maintenance-friendly features include the patented low maintenance surge damper system; bolt-on upper and lower spring guides; “tool-less” oil check sight glasses; sidewall hand access system for wire cloth clamp bars; bottom deck feed curtain; optional magnetic deck wear liners, optional “TOPS 2.0” oil filtering system.
- Patented “flow-through” lubrication system and patented “sealed-for-life” double O-ring construction provides maximum equipment life

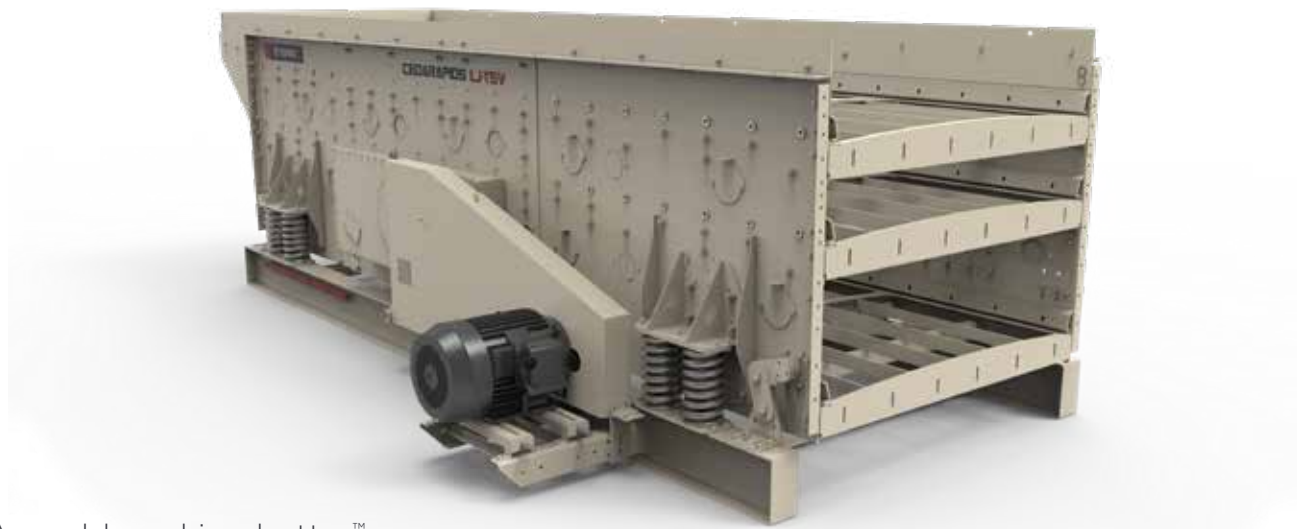

A world working better™



Low maintenance, no adjustment surge damper system



Optional deflector plates increase bottom deck effective area and capacity

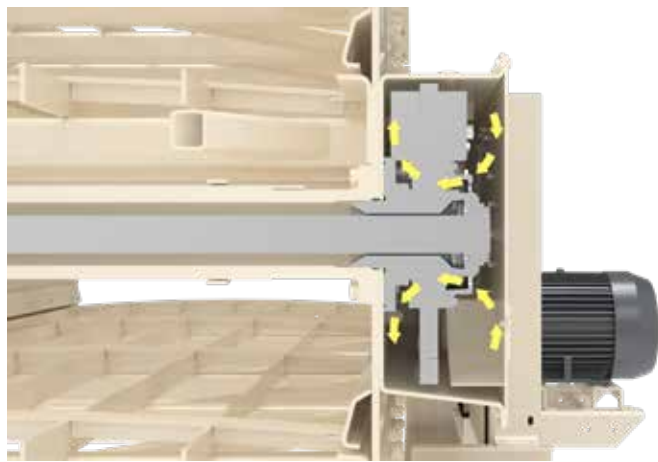

Cross-Section of Lubrication TSV6203

Applications



Ore/Hard Rock Mining



Quarried Stone



River Gravel



Recycle Concrete

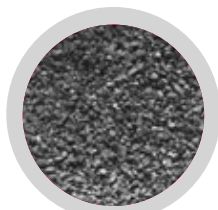

Fractured Gravel



Cubical Products

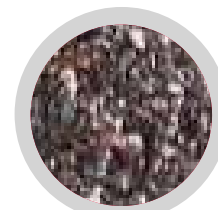

Washing, Recycled Asphalt

Standard Features

- Oval stroke with adjustable angle, stroke and speed
- 25% thicker 5/16" (8 mm) grade 50 high strength steel side plates
- Heavy-duty fully braced single crown steel deck construction
- Spring mounts adjust for 0°, 2.5°, 5°, 7.5° or 10° slope installations
- Exclusive patented features for durability and easy maintenance:
 - Low maintenance vibration damper system
 - "Flow-through" bearing lubrication
 - Baffled splash lubrication system
 - Double O-ring sealed for life vibrator construction
 - Patented dual pivot no maintenance surge dampers
- Screen cloth clamp bar hand access system with removable covers
- Spherical washer design eliminates sidewall welds
- Huck-bolted screen box construction (no welds)
- Extended life coil spring suspension
- Replaceable bolt-on spring guides
- Gland type non-wearing shaft seal
- Bottom deck feed curtain
- 4' (1219 mm) clamp bars with spherical washer tensioning system
- Extended life V-belt drive with sheaves for 1200 rpm motor
- Enclosed right-hand drive guard, motor mount, and tensioner
- Adjustable speed motor drive sheave and spring loaded belt tension idler
- Self aligning two row spherical roller bearings
- Synthetic broad range lubrication oil
- Spray pipe knock-outs
- Shaft tube liners
- Tool-less oil level sight glasses

Optional Equipment

- Medium scalping option (heavier top deck, side liner extensions, feedbox and discharge lip)
- High Speed Variable slope (HSV) option
- Patented bottom deck deflector plates boost capacity
- Replaceable magnetic deck wear liners
- End-tension bottom deck
- Flat decks for modular media
- Rigid I-beam base frame
- Left-hand drive assembly and guard
- 1500 rpm drive
- 5' (1524 mm) wire clamp bars (620 and 720 models)
- Rubber spring suspension
- Spray system (nozzle or splash)
- Wire screen cloth
- Wedge tensioning for wire cloth
- Cylinder tray for bottom deck
- Screen-duty electric motor (1200 rpm or 1500 rpm)
- TOPS2.0 Terex Oil Purification System



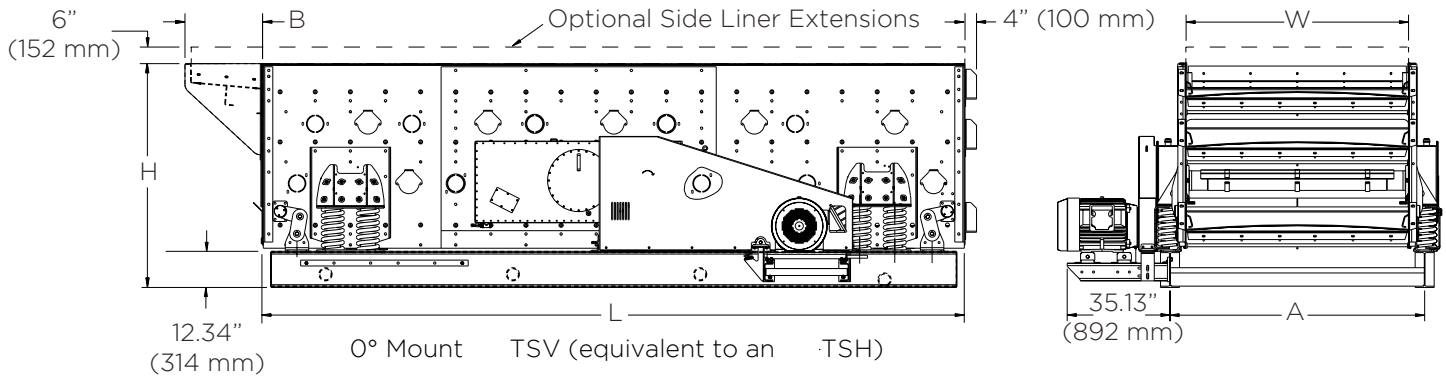

Dimension in inches (mm) for Standard Coil Springs
**Subtract 1.25" (32 mm) for Optional Rubber Springs

Screen	1200 rpm	*Weight	**H @ 0°	**H @ 2.5°	**H @ 5°	**H @ 7.5°	**H @ 10°	L	W	A	B
TSV 5162-26	25hp (19kW)	14500lbs (6577kg)	58.58" (1488mm)	65.08" (1653mm)	77.2" (1961mm)	86.82" (2205mm)	95.34" (2422mm)	192" (4877mm)	61.5" (1562mm)	72.5" (1842mm)	20.39" (518 mm)
TSV 5163-26	30hp (22kW)	17500lbs (7938kg)	74.24" (1886mm)	80.89" (2055mm)	92.89" (2359mm)	101.93" (2589mm)	110.85" (2816mm)	192" (4877mm)	61.5" (1562mm)	72.5" (1842mm)	20.39" (518mm)
TSV 6162-32	30hp (22kW)	15900lbs (7212kg)	58.58" (1488mm)	65.08" (1653mm)	77.2" (1961mm)	86.82" (2205mm)	95.34" (2422mm)	192" (4877mm)	76" (1930mm)	87" (2210mm)	26.50" (673mm)
TSV 6163-32	40hp (30kW)	19600lbs (8890kg)	74.24" (1886mm)	80.89" (2055mm)	92.89" (2359mm)	101.93" (2589mm)	110.85" (2816mm)	192" (4877mm)	76" (1930mm)	87" (2210mm)	26.50" (673mm)
TSV 6202-32	40hp (30kW)	19100lbs (8665kg)	60.15" (1528mm)	68.89" (1749mm)	82.87" (2105mm)	94.00" (2388mm)	105.04" (2667mm)	240" (6096mm)	76" (1930mm)	87" (2210mm)	26.50" (673mm)
TSV 6203-32	40hp (30kW)	22650lbs (10275kg)	76.46" (1942mm)	85.14" (2163mm)	99.12" (2518mm)	110.17" (2798mm)	121.01" (3074mm)	240" (6096)	76" (1930mm)	87" (2210mm)	26.50" (673mm)
TSV 7202-38	50hp (37kW)	23000lbs (10435kg)	62.24" (1581mm)	73.06" (1856mm)	84.98" (21589mm)	96.16" (2442mm)	107.1" (2720mm)	240" (6096mm)	88" (2235mm)	99" (2515mm)	26.50" (673mm)
TSV 7203-38	50hp (37kW)	27500lbs (12475kg)	81.85" (2070mm)	92.81" (2358mm)	104.75" (2661mm)	115.55" (2935mm)	126.67" (3217mm)	240" (6096mm)	88" (2235mm)	99" (2515mm)	26.50" (673mm)
TSV 8202-38	50hp (37kW)	24250lbs (11000kg)	62.05" (1577mm)	72.88" (1852mm)	84.77" (2153mm)	95.91" (2436mm)	106.99" (2718mm)	240" (6096mm)	100" (2540mm)	111" (2819mm)	26.50" (673mm)
TSV 8203-38	50hp (37kW)	29500lbs (13385kg)	81.91" (2081mm)	92.75" (2356mm)	104.57" (2656mm)	115.61" (2937mm)	126.43" (3211mm)	240" (6096mm)	100" (2540mm)	111" (2819mm)	26.50" (673 mm)

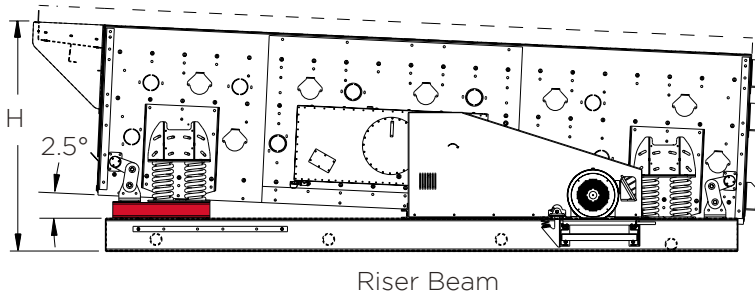

Riser Beam

2.5° Mount LJ-TSV (equivalent to an LJ-TSS or FSG)

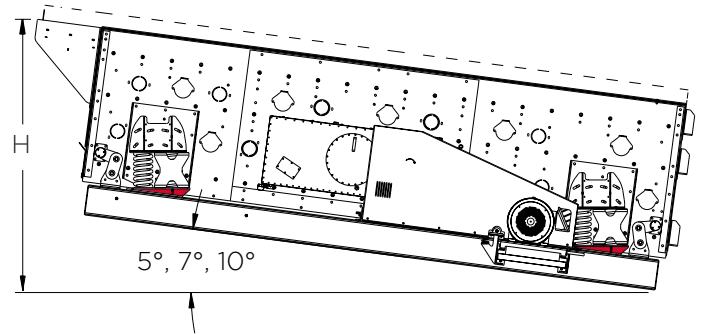

5°, 7°, 10° Wedges

Specifications

Maximum stroke (stroke can be reduced by removing weight plugs)	3/4"	19 mm
Recommended speed range	675 - 875 rpm	
Maximum feed size, standard decks	10"	254 mm
Maximum feed size, medium scalping decks	14"	356 mm
Maximum drop of feed	18"	457 mm
Discharge lip liner thickness (AR plate)	1/4"	6 mm
Feed box liners, standard (AR plate)	1/4"	6 mm
Feed box liners, medium scalping (AR plate)	3/8"	9.5 mm
Bearing size (516 models)		130 mm
Bearing size (616 and 620 models)		160 mm
Bearing size (720 and 820 models)		190 mm
Wire cloth length, standard	4'	1219 mm
Wire cloth length, optional (620 and 720 models)	5'	1524 mm

Screen Slope	Maximum Media Opening		Material Travel Rate	
0°	3"	76 mm	60 ft/minute	18.3 m/minute
2.5°	3.5"	89 mm	64 ft/minute	19.2 m/minute
5°	4.5"	114 mm	77 ft/minute	23.5 m/minute
7.5°	6"	152 mm	99 ft/minute	30.2 m/minute
10°	6"	152 mm	130 ft/minute	39.6 m/minute

*Stroke for HSV option is 7/16". Recommended speed range increases to 1000 rpm for HSV option.

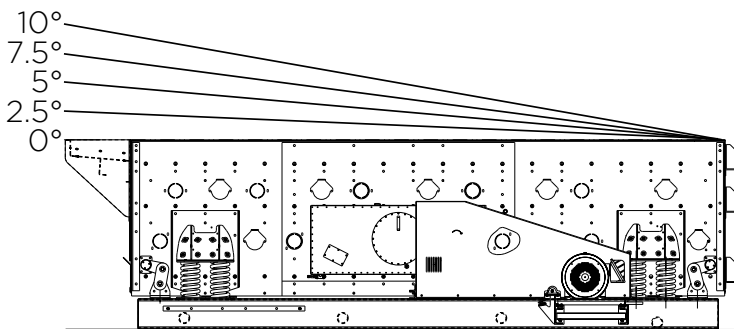

TSV screen installs from 0° up to 10° in 2.5° increments

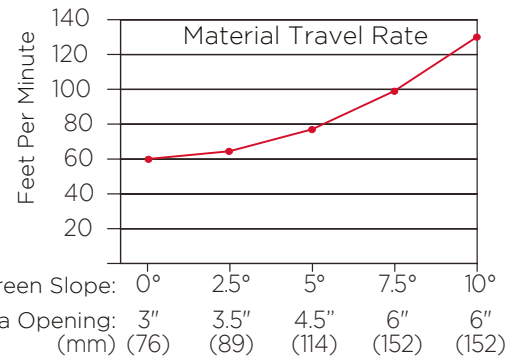

Max Media Opening: 3" (76) 3.5" (89) 4.5" (114) 6" (152) 6" (152)

Versatility for Your Application

Available as static screens for a custom fit for your application or available in pre-engineered modular and portable options for easy transport and installation.

Modular



Model	Main Components	Motor Size	Shipping Configuration
MHS6203	TSV6203 (6' x 20') Three deck Horizontal screen	40 hp (30 kW)	(2) 40ft shipping container plus (1) flat rack or (1) additional shipping container
MHS8203	TSV8203 (8' x 20') Three deck Horizontal screen	50 hp (37 kW)	(2) 40ft shipping container plus (1) flat rack

Portable



Model	Main Components	Motor Size	Suspension	Weight lbs (Kg)
CRS620H	TSV6203 (6' x 20') Three Deck Horizontal Screen	40 hp (30 kW)	2 Axle	53,000 lbs (24,045 Kg)
CRS620S	TSV6203 (6' x 20') Three Deck Adjustable Slope Screen	40 hp (30 kW)	2 Axle	53,000 lbs (24,045 Kg)
CRS820H	TSV8203 (8' x 20') Three Deck Horizontal Screen	50 hp (31 kW)	2 Axle	61,000 lbs (27,770 Kg)
CRS820C	TSV8203 (8' x 20') Three Deck Horizontal Screen with Feed Conveyor	50 hp (31 kW)	3 Axle	84,700 lbs (38,419 Kg)



Cedarapids TSV horizontal screens can also be found on several crushing and screening combination portable plants.

Model	Main Components	Motor Size	Capacity (MTPH)	Suspension	Weight lbs (Kg)
CRC380XHLS	MVP380X cone and TSV6203 three deck screen	300 hp (224 kW)	170-560 (155-507)	3 Axle & 4 Axle	138,300 lbs (62,735 Kg)
CRC1150S	TC1150 cone and TSV6203 three deck screen	300 hp (224 kW)	165-320 (150 - 290)	3 Axle	66,100 lbs (29,990 Kg)

Cedarapids® Services

Proven Success, Global Reach

A comprehensive range of services. Original spare and wear parts. Customizable solutions to meet your exact needs. Outstanding technical expertise and support.

This is what Cedarapids® delivers to businesses – and what it delivers to businesses throughout the world via our global distribution network, service and distribution facilities and regional warehouses.

Spare and Wear Part Support

Our OEM parts help maintain and enhance the performance of your equipment – and you can count on us to get you the spare and wear parts you need, when you need them.

Cedarapids® parts are manufactured according to exact specifications, using high-quality materials, tools and techniques. By using genuine parts you are helping to ensure the maximum performance and longevity of your machines.

A Shared Focus

We understand your key focus is delivering your operational and financial goals. We share that focus: it's how we both measure success.

By combining our global service network and proven, in-depth industry knowledge with your operational expertise we're able to provide you with the right solution to deliver a quality end product – with increased productivity.

Field Services

We offer a comprehensive set of field services to meet your maintenance, repair and refurbishment needs – which means you get a cost-effective alternative to purchasing new or replacement equipment.

Our experienced field service and distribution network are available to you on site or at our global service facilities. We can repair broken or damaged equipment to like-new condition and restore worn or irreplaceable equipment to perfect operating condition – which minimizes costly downtime for you.



Combining our global service network and deep industry knowledge with your operational expertise ensures that we provide the best solutions...

Terex® Financial Services

At Cedarapids® we not only offer a strong and broad product portfolio. We also offer the means for customers to purchase the equipment they need in order to meet their operational and profitability goals.

Terex® Financial Services is a globally trusted resource that is able to leverage its knowledge of Terex® equipment plus its marketplace expertise to provide a unique tailored solution for customers.

Terex® Financial Services at a Glance

- Providing cost-effective financial solutions to thousands of customers across the globe
- A comprehensive suite of financial solutions tailored to fit individual needs
- Dedicated and knowledgeable team with global reach, focused on customer solutions.

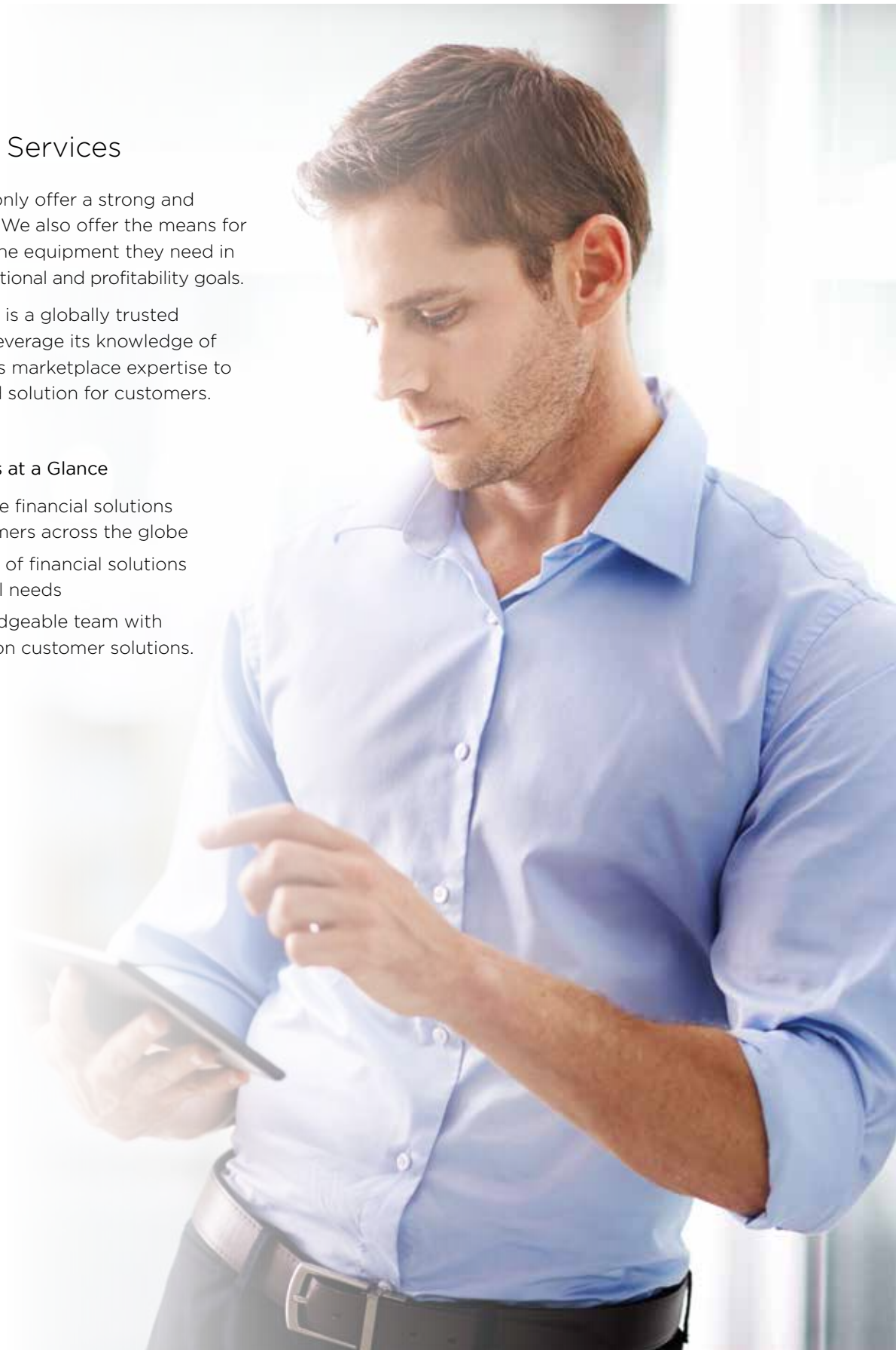



terex.com/cedarapids
Cedarapids.Marketing@Terex.com

Product specifications and prices are subject to change without notice or obligation. The photographs and/or drawings in this document are for illustrative purposes only. Refer to the appropriate Operator's Manual for instructions on the proper use of this equipment.

Failure to follow the appropriate Operator's Manual when using our equipment or failure to act responsibly may result in serious injury or death.

The only warranty applicable to our equipment is the standard written warranty applicable to the particular product and sale, and Terex makes no other warranty, express or implied. Terex, the Terex Crown design, Cedarapids, Canica, Simplicity, Jaques, El-Jay and Rollercone are trademarks of Terex Corporation or its subsidiaries. All rights are reserved. © April 2024

