

# WRC-80

## WHEELED RADIAL CONVEYOR

### PRODUCT OVERVIEW

The Marco WRC-80 Wheeled Radial Stockpiling Conveyor is the ideal solution for stockpiling material after mobile crushing and screening plants to build a stockpile and ensure a consistent quality product. It can also be integrated seamlessly into stationary plants.

Available in either Pit or Road towable variants, the WRC-80 is a simple but efficient radial conveyor. The machine is powered via hydraulic drive plug-in as standard enabling it to be powered by secondary equipment on site. The machine can also be configured with either electric or diesel hydraulic drive systems.

The WRC-80 features an optional radial hydraulic function, lattice design for increased strength and reduced weight.

With a maximum discharge height of 32' 7" (9.95m) when operated in conical mode the machine will stockpile 2544 tons (2313 Metric tons) of material. When configured to operate at 270° Kidney Bean mode the machine will stockpile 22158 tons (20144 Metric tons) of material.

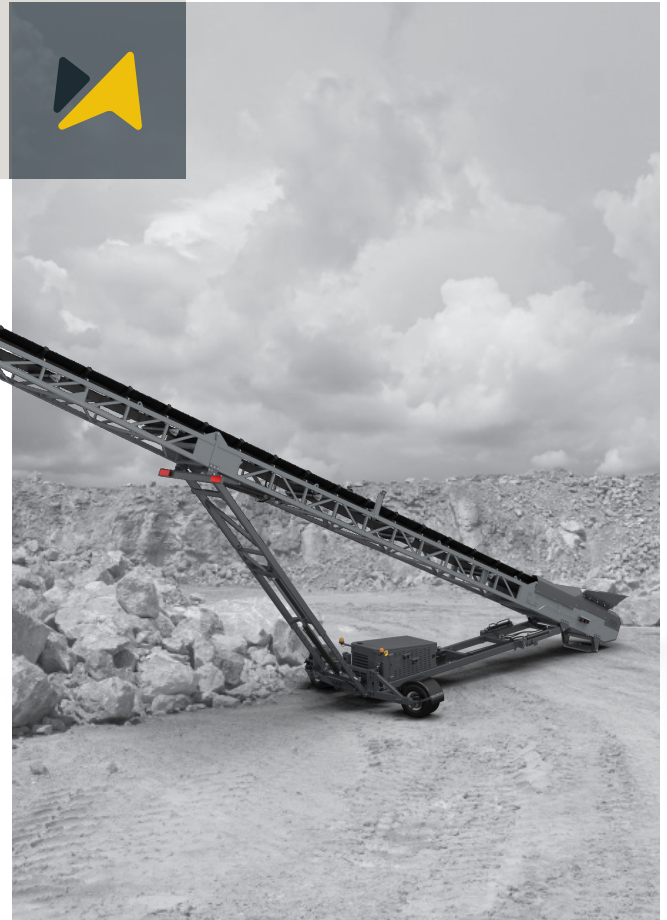

### PRODUCT FEATURES

#### Main Characteristics

- 01** The machine can be configured with electric drive, diesel hydraulic and hydraulic plugin which allows the machine to be powered from a secondary hydraulic power source.
- 02** Pit Chassis version has a braked hub which allows the operator to easily stop the machine in the desired position after changing the radial direction.
- 03** The machine features a 74' 10" (22.85m) discharge conveyor that has the capacity to transfer up to 330 tph (300 mtpb) of material.



## WORKING DIMENSIONS

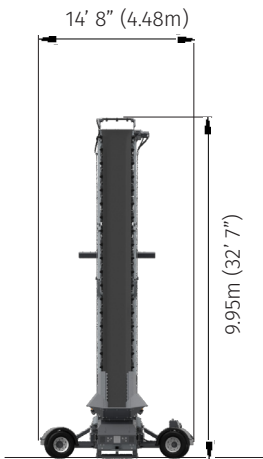
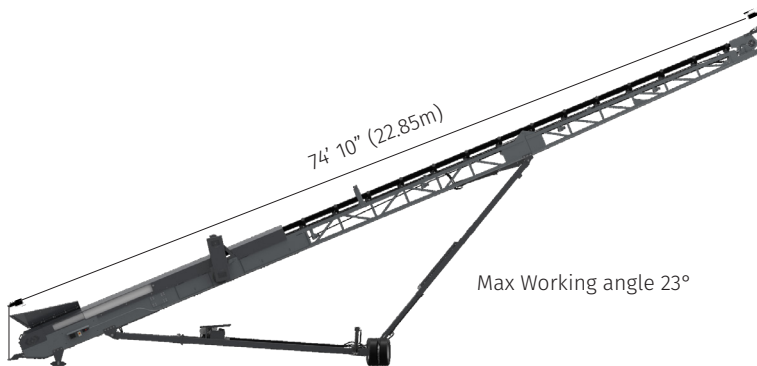

### MACHINE WEIGHT:

22,046lbs (10,000 kg)  
(Max Weight with full options)

### TRANSPORT DIMENSIONS

Length:  
Width:  
Height:  
Max Weight (with full options):  
Containerised shipping:

### ROAD TOWABLE

16.17m (52' 11")  
2.5m (8' 3")  
3.36m (11')  
10,000kgs (22,046lbs)  
2 x WRC80 per 40' x 9' 6" High Cube Container

### PIT PORTABLE

16.55m (54' 3")  
3.1m (10' 2")  
3.95m (12' 11")

## WARRANTY

At Marco, we stand behind the quality and craftsmanship of our products. Each Marco product comes with a comprehensive warranty designed to provide you with peace of mind. We are committed to ensuring your satisfaction with Marco products. If you have any questions or concerns regarding your warranty coverage, please don't hesitate to reach out to us.

Thank you for choosing Marco.

## FEED HOPPER

Capacity (Low Level): 0.43 yd<sup>3</sup> (0.35m<sup>3</sup>)  
Feed in Width (Low Level): 2' 6.5" (775mm)  
Minimum Feed In Height (Low Level) (7°): 5' 1534mm  
Capacity (Extended): 1.4 Cu. Yd. (1.1m<sup>3</sup>)  
Feed in Width (Extended): 5' 2" (1658mm)  
Extended Minimum Feed in Height (7°): 5' 10" (1793mm)

## POWERUNITS OPTIONS

Engine: CAT 1.7T Power rating: 24HP (18.4kW)  
Electric drive: 20HP (15kW) (up to 300tph)  
Engine: CAT C2.2 Power rating: 74HP (55kW) (up to 500tph)  
Electric drive: 30kW (up to 500tph)

## DISCHARGE CONVEYOR

Conveyor length: 74' 10 (22.85m)  
Belt Width: 36" (914mm)  
Belt Type: Plain  
Belt Spec: EP400 3 4+2  
Conveyor drive: Hydraulic or Electric  
Maximum working: 23°  
Maximum discharge height: 30' 1" (9.2m)  
Maximum stockpile: 20,143 yd<sup>3</sup> (12,590m<sup>3</sup>)

## CONVEYOR DETAILS

Discharge conveyor length: 22.85m (74' 10)  
Belt width: 914mm (36")  
Max. discharge height: 9.95m (32' 7") @ 23°  
Production capacity: Up to 300 TPH

## CONTACT US!

561 State Drive  
Mt. Vernon, MO 65712  
United States of America  
(417) 466-2774

marco@terex.com  
terex.com/marco

