

GTH Test Ramp

- Designed Test Ramp for Telehandler.
- Ramp is used for testing Parking Brake, gradient test

Projected Benefits:

- ✓ Productivity: Improved Productivity
- ✓ Improved Safety

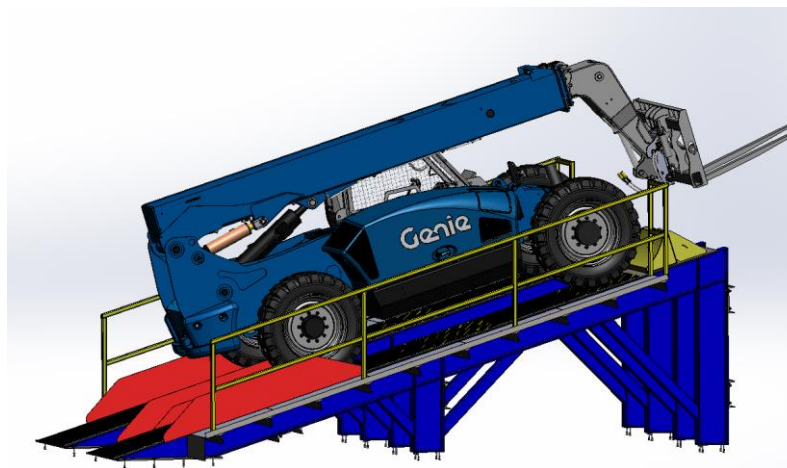
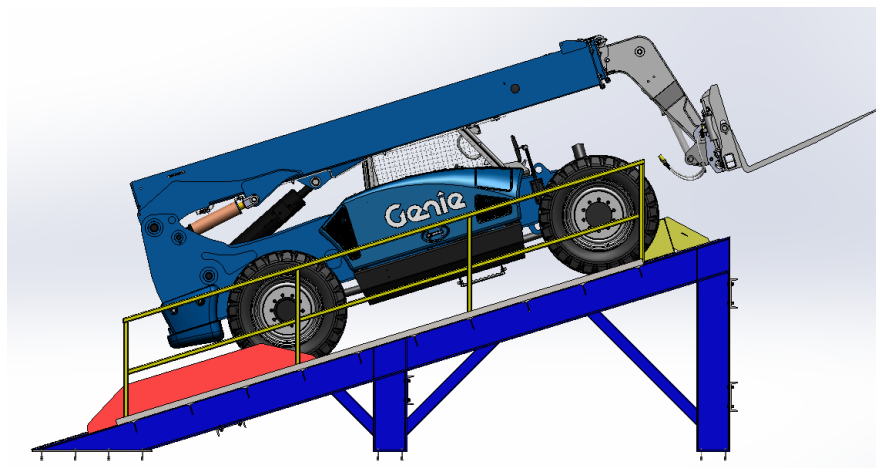

Mobile Crane Cab Test Fixture



- Designed, Manufactured, tested and implemented Cab test fixture for Mobile Crane
- Test Fixture is connected to the Cab at the assembly station (on ground before installation on the machine). Most of the Cab functions are Tested and verified before the cab is installed on the crane.

Projected Benefits:

- ✓ Productivity: Improved Productivity by eliminating rework after cab installation on the machine.

1:25 Scaled Mockup Model

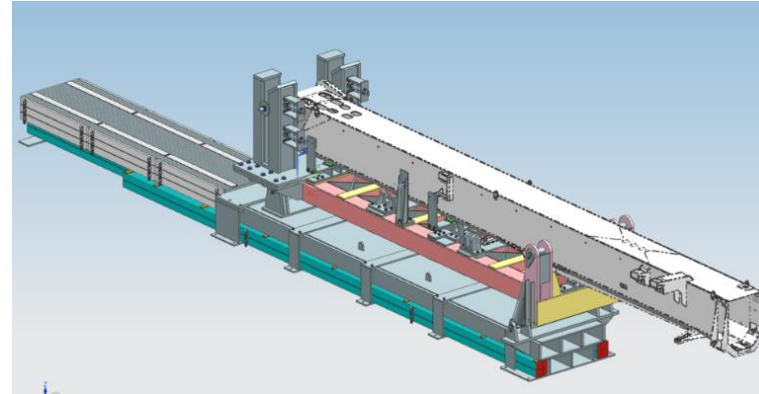
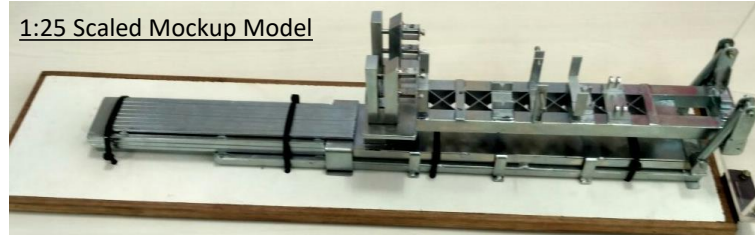

Mobile Crane Boom Test Fixture

- Designed a Test Fixture which is common for all variants of Boom used at the site: QS1100, RT500, T300, RT780, RT230, XO45, BT70100 & T120
- The fixture has been Tested and Proven to be effective in increasing the efficiency of testing the Boom
- The fixture helps in avoiding the rework after assembly onto the machine

Projected Benefits:

- ✓ Safety: Eliminated use of Forklifts, No Working @ Height during testing
- ✓ Productivity: Implemented boom test fixture to perform on-ground testing and corrective actions prior to installation on frame

